

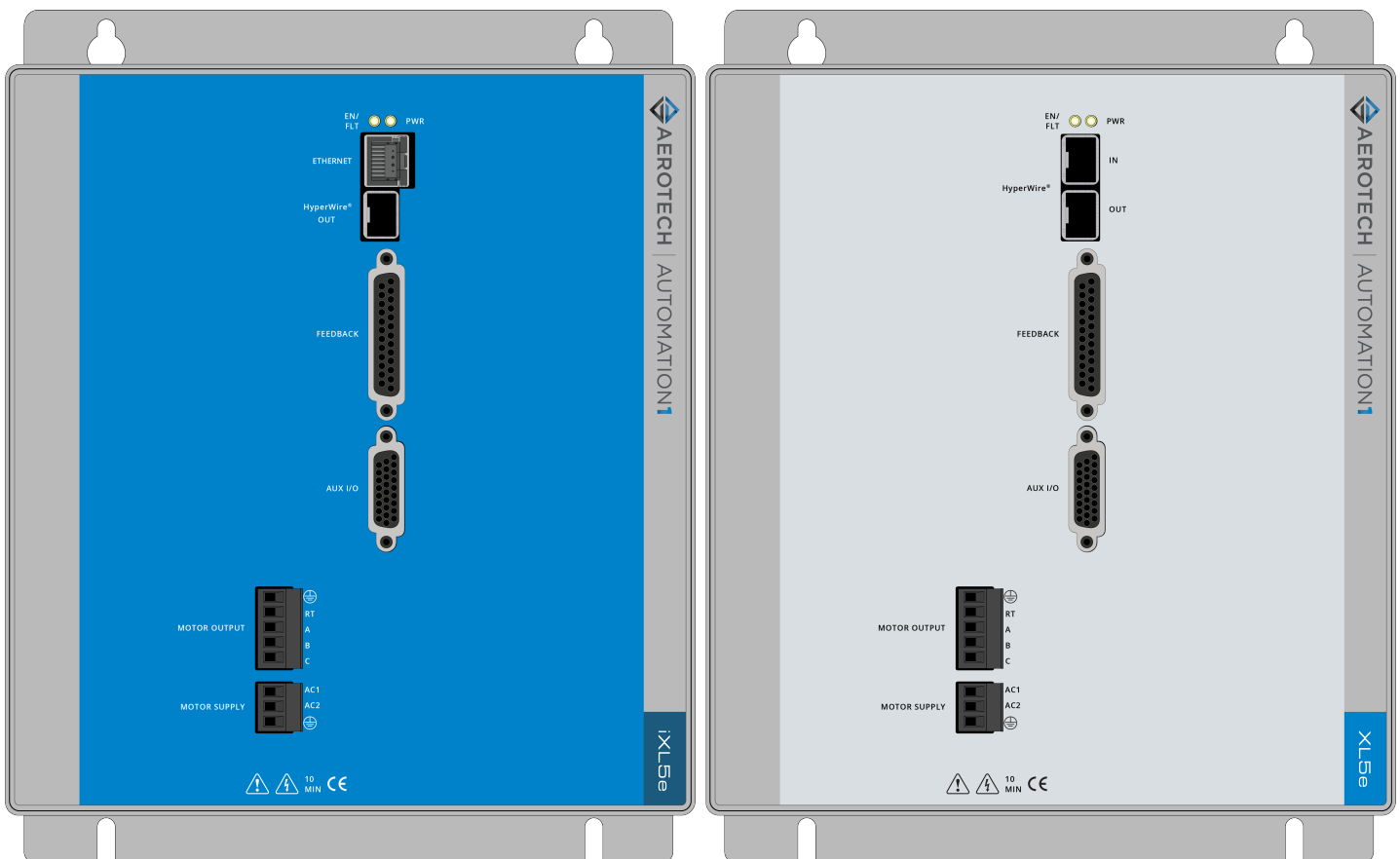

Automation1 iXL5e and XL5e High-Performance Linear Digital Drives

HARDWARE MANUAL

Revision 1.14



GLOBAL TECHNICAL SUPPORT

Go to the [Global Technical Support Portal](#) for information and support about your Aerotech, Inc. products. The website supplies software, product manuals, Help files, training schedules, and PC-to-PC remote technical support. If necessary, you can complete Product Return (RMA) forms and get information about repairs and spare or replacement parts. To get help immediately, contact a service office or your sales representative. Include your customer order number in your email or have it available before you call.

This manual contains proprietary information and may not be reproduced, disclosed, or used in whole or in part without the express written permission of Aerotech, Inc. Product names mentioned herein are used for identification purposes only and may be trademarks of their respective companies.

Copyright © 2019-2024, Aerotech, Inc., All rights reserved.



Table of Contents

Automation1 iXL5e and XL5e High-Performance Linear Digital Drives	1
Table of Contents	3
List of Figures	5
List of Tables	7
EU Declaration of Conformity	9
UKCA Declaration of Conformity	10
Agency Approvals	11
Safety Procedures and Warnings	12
Handling and Storage	14
Installation Overview	15
Chapter 1: iXL5e/XL5e Overview	17
1.1. Feature Summary	19
1.2. Ordering Options	20
1.3. Functional Block Diagram	21
1.4. Electrical Specifications	22
1.4.1. System Power Requirements	23
1.4.2. Real-Time Clock Requirements (iXL5e Only)	23
1.5. Mechanical Specifications	24
1.5.1. Mounting and Cooling	24
1.5.2. Dimensions	25
1.6. Environmental Specifications	27
1.7. Drive and Software Compatibility	27
Chapter 2: Installation and Configuration	29
2.1. Input Power Connections	29
2.1.1. Control Supply Connector	29
2.1.2. Motor Supply Connector	30
2.2. Motor Power Output Connector	31
2.2.1. Brushless Motor Connections	32
2.2.1.1. Brushless Motor Powered Motor and Feedback Phasing	33
2.2.1.2. Brushless Motor Unpowered Motor and Feedback Phasing	34
2.2.2. DC Brush Motor Connections	35
2.2.2.1. DC Brush Motor Phasing	36
2.2.3. Stepper Motor Connections	37
2.2.3.1. Stepper Motor Phasing	37
2.2.4. Three Phase Stepper Motor Connections	38
2.2.4.1. Stepper Motor Phasing	38
2.3. Feedback Connector	39
2.3.1. Primary Encoder Inputs	40
2.3.1.1. Square Wave Encoder (Primary)	41
2.3.1.2. Absolute Encoder (Primary)	42
2.3.1.3. Sine Wave Encoder (Primary) [-MX2/-MX3 Option]	43
2.3.1.4. Encoder Phasing	45
2.3.2. Hall-Effect Inputs	46
2.3.3. Thermistor Input	47
2.3.4. Encoder Fault Input	48
2.3.5. End of Travel and Home Limit Inputs	49
2.3.5.1. End of Travel and Home Limit Phasing	51
2.3.6. Brake Outputs	52
2.4. Safe Torque Off Input (STO)	53
2.4.1. STO Standards	55
2.4.2. STO Functional Description	56
2.4.3. STO Startup Validation Testing	57
2.4.4. STO Diagnostics	58
2.5. Auxiliary I/O Connector	59
2.5.1. Auxiliary Encoder Interface	60
2.5.1.1. Square Wave Encoder (Auxiliary)	61
2.5.1.2. Absolute Encoder (Auxiliary)	62

2.5.1.3. Sine Wave Encoder (Auxiliary) [-MX3 Option]	63
2.5.2. Position Synchronized Output (PSO)	65
2.5.3. Digital Outputs	67
2.5.4. Digital Inputs	70
2.5.5. High-Speed Inputs	72
2.5.6. Analog Output 0	73
2.5.7. Analog Input 0 (Differential)	74
2.6. Brake Power Supply Connector	75
2.7. HyperWire Interface	76
2.8. Sync Port	77
2.9. Industrial Ethernet (iXL5e Only)	77
2.10. System Interconnection	78
2.11. PC Configuration and Operation Information	81
Chapter 3: -EB1 Option Expansion Board	83
3.1. Digital Outputs [-EB1]	84
3.2. Digital Inputs [-EB1]	88
3.3. Analog Outputs [-EB1]	91
3.4. Analog Inputs [-EB1]	92
3.5. PSO Interface [-EB1]	93
Chapter 4: Cables and Accessories	95
4.1. Joystick Interface	96
4.2. Handwheel Interface	98
Chapter 5: Maintenance	99
5.1. Preventative Maintenance	100
5.2. Fuse Specifications	101
Appendix A: Warranty and Field Service	103
Appendix B: Voltage Selection Operation	105
Appendix C: Revision History	107
Index	109

List of Figures

Figure 1-1:	iXL5e High Performance Linear Amplifier	17
Figure 1-2:	XL5e High Performance Linear Amplifier	18
Figure 1-3:	Functional Diagram	21
Figure 1-4:	Dimensions	25
Figure 1-5:	Dimensions [-EB1]	26
Figure 2-1:	Control Supply Connections	29
Figure 2-2:	Motor Supply Connections	30
Figure 2-3:	Brushless Motor Configuration	32
Figure 2-4:	Positive Motor Direction	33
Figure 2-5:	Encoder and Hall Signal Diagnostics	33
Figure 2-6:	Brushless Motor Phasing Oscilloscope Example	34
Figure 2-7:	Brushless Motor Phasing Goal	34
Figure 2-8:	DC Brush Motor Configuration	35
Figure 2-9:	DC Brush Motor Configuration	35
Figure 2-10:	Positive Motor Direction	36
Figure 2-11:	Stepper Motor Configuration	37
Figure 2-12:	Positive Motor Direction	37
Figure 2-13:	Three Phase Stepper Motor Configuration	38
Figure 2-14:	Positive Motor Direction	38
Figure 2-15:	Square Wave Encoder Schematic (Feedback Connector)	41
Figure 2-16:	Absolute Encoder Schematic (Feedback Connector)	42
Figure 2-17:	Sine Wave Encoder Phasing Reference Diagram	43
Figure 2-18:	Sine Wave Encoder Schematic (Feedback Connector)	44
Figure 2-19:	Encoder Phasing Reference Diagram (Standard)	45
Figure 2-20:	Position Feedback in the Diagnostic Display	45
Figure 2-21:	Hall-Effect Inputs Schematic (Feedback Connector)	46
Figure 2-22:	Thermistor Input Schematic (Feedback Connector)	47
Figure 2-23:	Encoder Fault Input Schematic (Feedback Connector)	48
Figure 2-24:	End of Travel and Home Limit Input Connections	50
Figure 2-25:	End of Travel and Home Limit Input Schematic (Feedback Connector)	50
Figure 2-26:	End of Travel and Home Limit Input Diagnostic Display	51
Figure 2-27:	Brake Connected to the 25-Pin Feedback Connector (Typical)	52
Figure 2-28:	Typical STO Configuration	54
Figure 2-29:	STO Timing	58
Figure 2-30:	Square Wave Encoder Interface (Aux I/O Connector)	61
Figure 2-31:	Absolute Encoder Schematic (Auxiliary I/O Connector)	62
Figure 2-32:	Sine Wave Encoder Phasing Reference Diagram	63
Figure 2-33:	Sine Wave Encoder Schematic (Auxiliary I/O Connector)	64
Figure 2-34:	PSO Interface	66
Figure 2-35:	Digital Output Schematic (Aux I/O Connector)	68
Figure 2-36:	Digital Outputs Connected in Current Sourcing Mode	69
Figure 2-37:	Digital Outputs Connected in Current Sinking Mode	69
Figure 2-38:	Digital Inputs Schematic (Aux I/O Connector)	70
Figure 2-39:	Digital Inputs Connected to Current Sourcing Devices	71
Figure 2-40:	Digital Inputs Connected to Current Sinking Devices	71
Figure 2-41:	High-Speed Inputs	72
Figure 2-42:	Analog Output 0 Schematic	73
Figure 2-43:	Analog Input 0 Schematic	74

Figure 2-44: Drive-Based System Wiring Drawing (Best Practice)	78
Figure 2-45: PC-Based System Wiring Drawing (Best Practice)	78
Figure 2-46: Recommended System Connections for a Drive-Based Controller	79
Figure 2-47: Recommended System Connections for a PC-Based Controller	80
Figure 3-1: -EB1 I/O Option Board Connectors (iXL5e shown)	83
Figure 3-2: Digital Outputs Schematic [-EB1]	86
Figure 3-3: Digital Outputs Connected in Current Sourcing Mode [-EB1]	87
Figure 3-4: Digital Outputs Connected in Current Sinking Mode [-EB1]	87
Figure 3-5: Digital Inputs Schematic [-EB1]	89
Figure 3-6: Digital Inputs Connected to Current Sourcing (PNP) Devices [-EB1]	90
Figure 3-7: Digital Inputs Connected to Current Sinking (NPN) Devices [-EB1]	90
Figure 3-8: Analog Output Typical Connection [-EB1]	91
Figure 3-9: Analog Input Typical Connection [-EB1]	92
Figure 3-10: PSO Output Sources Current	94
Figure 3-11: PSO Output Sinks Current	94
Figure 3-12: PSO TTL Outputs Schematic	94
Figure 4-1: Two Axis Joystick Interface (to the Aux I/O of two drives)	96
Figure 4-2: Two Axis Joystick Interface (to the I/O board)	97
Figure 4-3: Handwheel Interconnection to Aux I/O Connector	98
Figure 4-4: Handwheel Interconnection to the Aux I/O through a BBA32 Module	98
Figure B-1: Voltage Selection Switch Access	106

List of Tables

Table 1-1: Example Order and Ordering Options	20
Table 1-2: Linear Amplifier Specifications	22
Table 1-3: Mounting Specifications	24
Table 1-4: Environmental Specifications	27
Table 1-5: Drive and Software Compatibility	27
Table 2-1: Control Supply Connector Pinout	29
Table 2-2: Control Supply Mating Connector Ratings	29
Table 2-3: Motor Supply Connector Pinout	30
Table 2-4: Motor Supply Mating Connector Ratings	30
Table 2-5: Motor Power Output Connector Pinout	31
Table 2-6: Motor Power Output Mating Connector Ratings	31
Table 2-7: Wire Colors for Aerotech-Supplied Brushless Motor Cables	32
Table 2-8: Hall Signal Diagnostics	33
Table 2-9: DC Brush Voltage Output Configuration	35
Table 2-10: Wire Colors for Aerotech-Supplied DC Brush Motor Cables	35
Table 2-11: Wire Colors for Aerotech-Supplied Stepper Motor Cables	37
Table 2-12: Feedback Connector Pinout	39
Table 2-13: Feedback Mating Connector Ratings	39
Table 2-14: Multiplier Options	40
Table 2-15: Primary Encoder Pins on the Feedback Connector	40
Table 2-16: Square Wave Encoder Specifications	41
Table 2-17: Absolute Encoder Specifications	42
Table 2-18: Sine Wave Encoder Specifications	43
Table 2-19: Hall-Effect Feedback Pins on the Feedback Connector	46
Table 2-20: Thermistor Input Pin on the Feedback Connector	47
Table 2-21: Encoder Fault Input Pin on the Feedback Connector	48
Table 2-22: End of Travel and Home Limit Pins on the Feedback Connector	49
Table 2-23: Brake Output Pins on the Feedback Connector	52
Table 2-24: Brake Control Specifications	52
Table 2-25: STO Connector Pinout	53
Table 2-26: STO Mating Connector Ratings	53
Table 2-27: STO Electrical Specifications	54
Table 2-28: STO Standards	55
Table 2-29: STO Standards Data	55
Table 2-30: STO Signal Delay	57
Table 2-31: Motor Function Relative to STO Input State	57
Table 2-32: STO Timing	58
Table 2-33: Auxiliary I/O Connector Pinout	59
Table 2-34: Auxiliary I/O Mating Connector Ratings	59
Table 2-35: Auxiliary Encoder Pins on the Auxiliary I/O Connector	60
Table 2-36: Square Wave Encoder Specifications	61
Table 2-37: Absolute Encoder Specifications	62
Table 2-38: Sine Wave Encoder Specifications	63
Table 2-39: PSO Specifications	65
Table 2-40: PSO Pins on the Auxiliary I/O Connector	65
Table 2-41: Digital Output Specifications	67
Table 2-42: Digital Output Pins on the Auxiliary I/O Connector	67
Table 2-43: Digital Input Specifications	70

Table 2-44: Digital Input Pins on the Auxiliary I/O Connector	70
Table 2-45: High-Speed Input Specifications	72
Table 2-46: High-Speed Input Pins on the Auxiliary I/O Connector	72
Table 2-47: Analog Output Specifications	73
Table 2-48: Analog Output Pins on the Auxiliary I/O Connector	73
Table 2-49: Analog Input Specifications	74
Table 2-50: Analog Input Pins on the Auxiliary I/O Connector	74
Table 2-51: Brake Power Supply Connector Pinout	75
Table 2-52: Brake Power Supply Mating Connector Ratings	75
Table 2-53: HyperWire Card Part Number	76
Table 2-54: HyperWire Cable Part Numbers	76
Table 2-55: Sync-Related Functions	77
Table 2-56: Sync Port Cables	77
Table 3-1: Digital Output Specifications [-EB1]	84
Table 3-2: Digital Output 1 Connector Pinout [-EB1]	85
Table 3-3: Digital Output 2 Connector Pinout [-EB1]	85
Table 3-4: Digital Output 1 and 2 Mating Connector Ratings [-EB1]	85
Table 3-5: Digital Input Specifications [-EB1]	88
Table 3-6: Digital Input 1 Connector Pinout [-EB1]	88
Table 3-7: Digital Input 2 Connector Pinout [-EB1]	89
Table 3-8: Digital Input 1 and 2 Mating Connector Ratings [-EB1]	89
Table 3-9: Analog Output Specifications [-EB1]	91
Table 3-10: Analog Output Connector Pinout [-EB1]	91
Table 3-11: Analog Output Mating Connector Ratings [-EB1]	91
Table 3-12: Differential Analog Input Specifications [-EB1]	92
Table 3-13: Analog Input Connector Pinout [-EB1]	92
Table 3-14: Analog Input Mating Connector Ratings [-EB1]	92
Table 3-15: PSO Specifications [-EB1]	93
Table 3-16: PSO Interface Connector Pinout [-EB1]	93
Table 3-17: PSO Interface Mating Connector Ratings [-EB1]	93
Table 4-1: Standard Interconnection Cables	95
Table 5-1: LED Description	99
Table 5-2: Troubleshooting	99
Table 5-3: Preventative Maintenance	100
Table 5-4: Fuse Specifications	101

EU Declaration of Conformity

Manufacturer Aerotech, Inc.
Address 101 Zeta Drive
 Pittsburgh, PA 15238-2811
 USA
Product iXL5e/XL5e
Model/Types All



This is to certify that the aforementioned product is in accordance with the applicable requirements of the following directive(s):

2014/30/EU	Electromagnetic Compatibility (EMC)
2014/35/EU	Low Voltage Directive
2006/42/EC	Machinery Directive
EU 2015/863	Directive, Restricted Substances (RoHS 3)

and has been designed to be in conformity with the applicable requirements of the following standard(s) when installed and used in accordance with the manufacturer's supplied installation instructions.

EN 61010-1:2010/AMD1:2016	Safety Requirements for Electrical Equipment
EN 61800-3:2017	EMC Requirements for Power Drives
IEC 61800-5-1:2016	Electrical Safety for Power Drive Systems
IEC 61800-5-2:2016	Functional Safety for Power Drive Systems
EN 55011/55032:2015	Conducted and Radiated Emissions

Authorized Representative:

/ Jochen Jäger

Operations Manager
 Aerotech GmbH
 Gustav-Weißkopf-Str. 18
 90768 Fürth
 Germany

Engineer Verifying Compliance

/ Alex Weibel

Aerotech, Inc.
 101 Zeta Drive
 Pittsburgh, PA 15238-2811
 USA
 8/15/2024

Date

UKCA Declaration of Conformity

Manufacturer Aerotech, Inc.
Address 101 Zeta Drive
 Pittsburgh, PA 15238-2811
 USA
Product iXL5e/XL5e
Model/Types All



To which this declaration relates, meets the essential health and safety requirements and is in conformity with the relevant UK Legislation listed below:

Electrical Equipment (Safety) Regulations 2016
 Electromagnetic Compatibility Regulations 2016
 Supply of Machinery (Safety) Regulations 2008
 Hazardous Substances in Electrical and Electronic Equipment Regulations 2012

Using the relevant section of the following UK Designated Standards and other normative documents when installed in accordance with the installation instructions supplied by the manufacturer.

EN 61010-1:2010/AMD1:2016	Safety Requirements for Electrical Equipment
EN 61800-3:2017	EMC Requirements for Power Drives
IEC 61800-5-1:2016	Electrical Safety for Power Drive Systems
IEC 61800-5-2:2016	Functional Safety for Power Drive Systems
EN 55011/55032:2015	Conducted and Radiated Emissions

Authorized Representative:

/ Simon Smith

Managing Director
 Aerotech Ltd
 The Old Brick Kiln, Ramsdell, Tadley
 Hampshire RG26 5PR
 UK

Engineer Verifying Compliance

/ Alex Weibel

Aerotech, Inc.
 101 Zeta Drive
 Pittsburgh, PA 15238-2811
 USA
 8/15/2024

Date

Agency Approvals

The iXL5e/XL5e drives have been tested by the following NRTL(s) and have been certified to the standards that follow:

Approval: CUS NRTL
Approving Agency: TÜV SÜD America Inc.
Certificate #: U10 068995 0033
Standards: CSA C22.2 No. 61010-1:2012/A1:2018-11,
 UL 61010-1:2012/R2019-07



Certificate #: N8AUS 068995 0032
Standards: CE Attestation of Conformity,
 Low Voltage Directive 2014/35/EU,
 EN 61010-1:2010/AMD1:2019

Approval: Safety Components (STO)
Approving Agency: TÜV SÜD
Certificate #: Z10 068995 0030 Rev. 01
Standards: IEC 61508-1:2010 (up to SIL3),
 IEC 61508-2:2010 (up to SIL3),
 ISO 13849-1:2023 (up to PL e),
 IEC 62061:2021 (maximum SIL 3)



Visit <https://www.tuev-sued.de/product-testing/certificates> to view Aerotech's TÜV SÜD certificates. Type the certificate number listed above in the search bar or type "Aerotech" for a list of all Aerotech certificates.

Safety Procedures and Warnings



IMPORTANT: This manual tells you how to carefully and correctly use and operate the drive.

- Read all parts of this manual before you install or operate the drive or before you do maintenance to your system.
- To prevent injury to you and damage to the equipment, obey the precautions in this manual.
- All specifications and illustrations are for reference only and were complete and accurate as of the release of this manual. To find the newest information about this product, refer to www.aerotech.com.

If you do not understand the information in this manual, contact Aerotech Global Technical Support.



IMPORTANT: This product has been designed for light industrial manufacturing or laboratory environments. If the product is used in a manner not specified by the manufacturer:

- The protection provided by the equipment could be impaired.
- The life expectancy of the product could be decreased.

Safety notes and symbols are placed throughout this manual to warn you of the potential risks at the moment of the safety note or if you fail to obey the safety note.



The voltage can cause shock, burn, or death.



You are at risk of physical injury.
You could damage the drive.



A surface can be hot enough to burn you.



Your actions, the temperature of the system, or the condition of the atmosphere that surround the system could start a fire.



Components are sensitive to electrostatic discharge.



Unsecured cables could cause you to:

- trip and fall
- drag the product off of its mounting location
- damage the cable connections.



A blue circle symbol is an action or tip that you should obey. Some examples include:

- General tip
- Read the manual/section
- Wear protective safety equipment (eye protection, ear protection, gloves)
- If applicable, do not lift unassisted





DANGER: To decrease the risk of electrical shock, injury, death, and damage to the equipment, obey the precautions that follow.

1. Before you do maintenance to the equipment, disconnect the electrical power.
2. Restrict access to the drive when it is connected to a power source.
3. Do not connect or disconnect electrical components, wires, and cables while this product is connected to a power source.
4. Wait at least ten (10) minutes after removing the power supply before doing maintenance or an inspection. Otherwise, there is the danger of electric shock.
5. Supply each operator with the necessary protection from live electrical circuits.
6. Make sure that all components are grounded correctly and that they obey the local electrical safety requirements.
7. Install the necessary precautions to supply safety and protection to the operator.



DANGER: System travel can cause crush, shear, or pinch injuries. Restrict access to all motor and stage parts while your system is connected to a power source.



WARNING: To prevent damage to the equipment and decrease the risk of electrical shock and injury, obey the precautions that follow.

1. Make sure that all system cables are correctly attached and positioned.
2. Do not use the cables or the connectors to lift or move this product.
3. Use this product only in environments and operating conditions that are approved in this manual.
4. Only trained operators should operate this equipment.

Handling and Storage

Unpacking the drive



IMPORTANT: All electronic equipment and instrumentation is wrapped in antistatic material and packaged with desiccant. Ensure that the antistatic material is not damaged during unpacking.

Inspect the shipping container for any evidence of shipping damage. If any damage exists, notify the shipping carrier immediately.

Remove the packing list from the shipping container. Make sure that all the items specified on the packing list are contained within the package.

The documentation for the drive is on the included installation device. The documents include manuals, interconnection drawings, and other documentation pertaining to the system. Save this information for future reference. Additional information about the system is provided on the Serial and Power labels that are placed on the chassis.

The system serial number label contains important information such as the:

- Customer order number (please provide this number when requesting product support)
- Drawing number
- System part number

Handling



IMPORTANT: It is the responsibility of the customer to safely and carefully lift and move the drive.

- Be careful when you move or transport the drive.
- Refer to [Section 1.5. Mechanical Specifications](#) for dimensions and weight specifications.
- Retain the shipping materials for future use.
- Transport or store the drive in its protective packaging.



WARNING: Electrostatic Discharge (ESD) Sensitive Components!

You could damage the power supply or drives if you fail to observe the correct ESD practices. Wear an ESD wrist strap when you handle, install, or do service to the system assembly.

Storage

Store the drive in the original shipping container. If the original packaging included ESD protective packaging, make sure to store the drive in it. The storage location must be dry, free of dust, free of vibrations, and flat.

Refer to [Section 1.6. Environmental Specifications](#).

Installation Overview

The images that follow show the order in which to make connections and settings that are typical to the iXL5e/XL5e. If a custom interconnect drawing was supplied with your system, that drawing is on your Storage Device and shows as a line item on your Sales Order in the Integration section.

Figure 1: Installation Connection Overview for the iXL5e

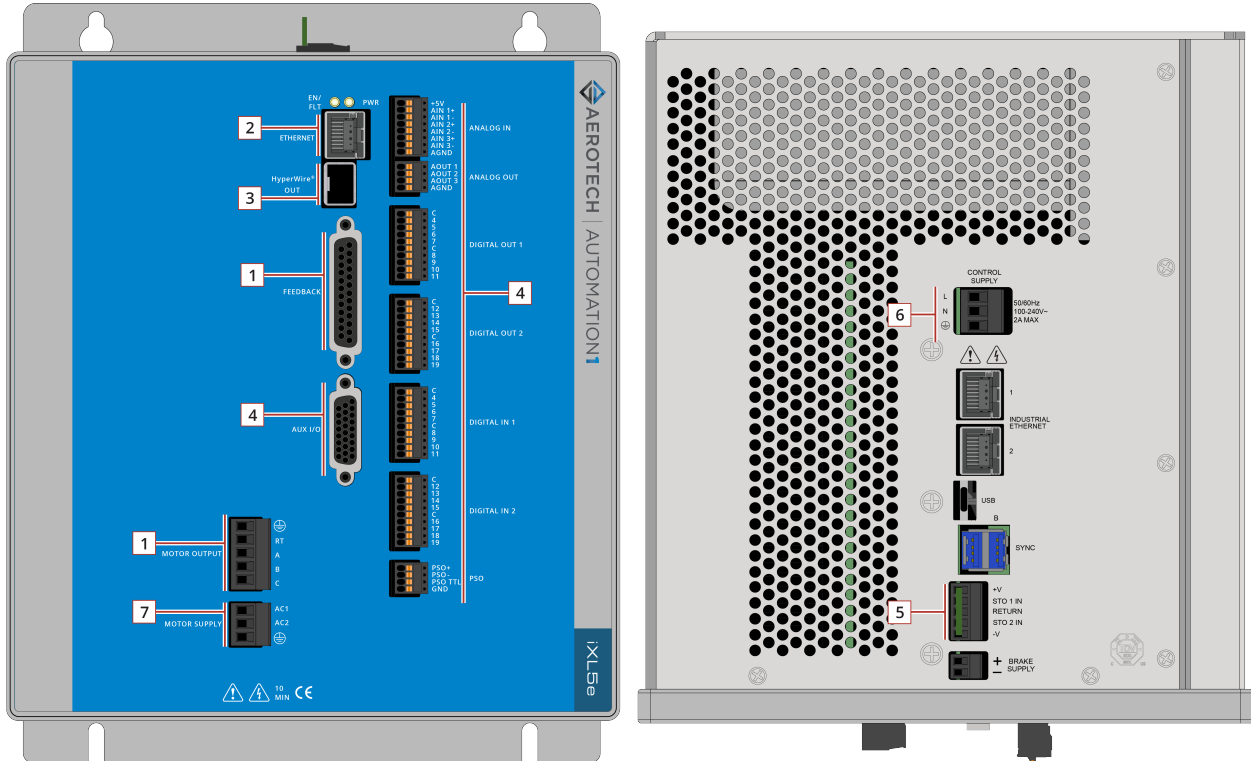

1	Connect the motor to the amplifier Motor Output connector.	Section 2.2.
	Connect the motor to the amplifier Feedback connector.	Section 2.3.
2	Connect the PC to the USB or Ethernet port.	N/A
3	Connect the next drive in the system to the HyperWire Out port.	Section 2.7.
4	Connect additional I/O as required by your application (if you purchased the I/O option).	Section 2.5./ Chapter 3
5	Connect the Safe Torque Off (STO).	Section 2.4.
6	Connect the power supply to the Control Supply connector.	Section 2.1.1.
7	Connect the motor power to the Motor Supply connector.	Section 2.1.2.

Figure 2: Installation Connection Overview for the XL5e

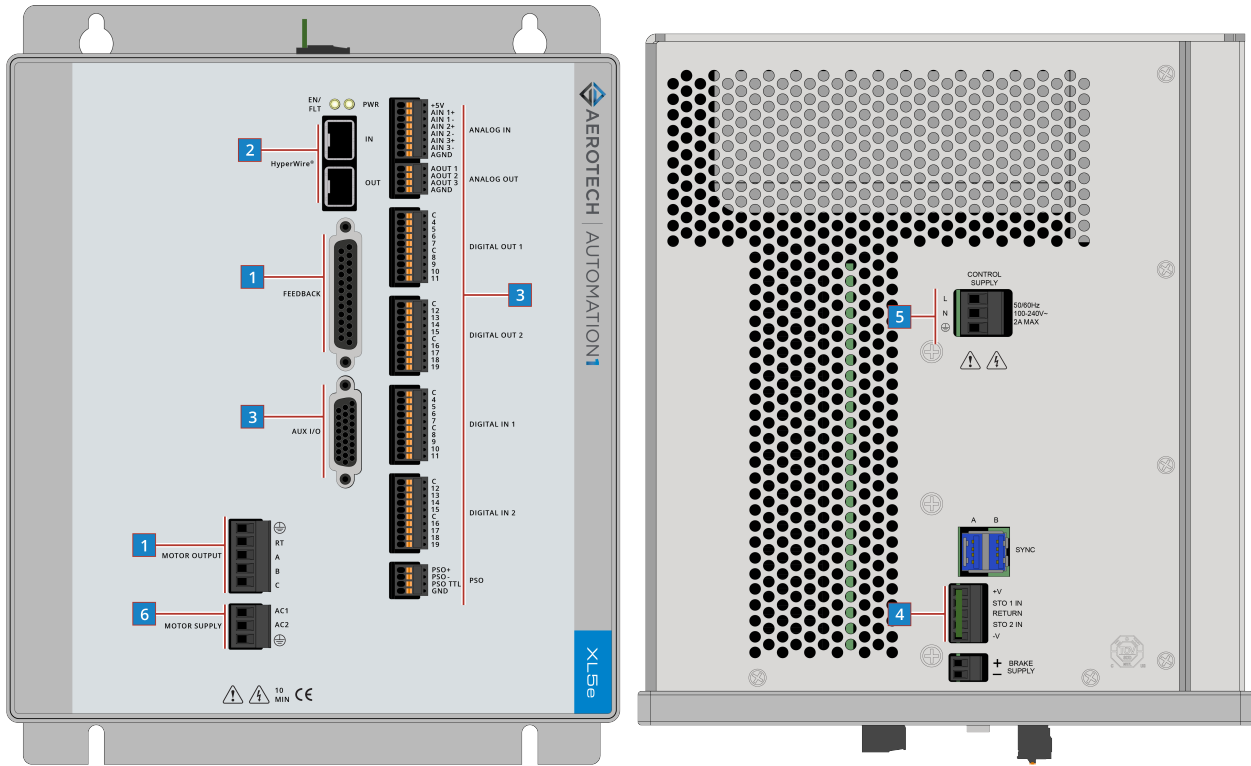

1	Connect the motor to the amplifier Motor Output connector.	Section 2.2.
1	Connect the motor to the amplifier Feedback connector.	Section 2.3.
2	Connect a PC or drive-based controller HyperWire port to the HyperWire In port.	Section 2.7.
3	Connect additional I/O as required by your application (if you purchased the I/O option).	Section 2.5./ Chapter 3
4	Connect the Safe Torque Off (STO).	Section 2.4.
5	Connect the power supply to the Control Supply connector.	Section 2.1.1.
6	Connect the motor power to the Motor Supply connector.	Section 2.1.2.

Chapter 1: iXL5e/XL5e Overview

The iXL5e is a high-performance digital drive-based controller. It runs the Automation1-iSMC controller to generate commands for itself as well as for additional drives on the chain.

The XL5e is a high performance digital drive. The XL5e is based on the HyperWire communication protocol and receives commands from a PC or drive-based controller.

Both drives have a linear amplifier designed for motion control applications that require the highest positioning accuracy and lowest generated noise. The drives are factory configured for the specified AC input voltage, motor output voltage, and current. Refer to [Section 1.1](#) for a complete list of features and ordering options.

Figure 1-1: iXL5e High Performance Linear Amplifier

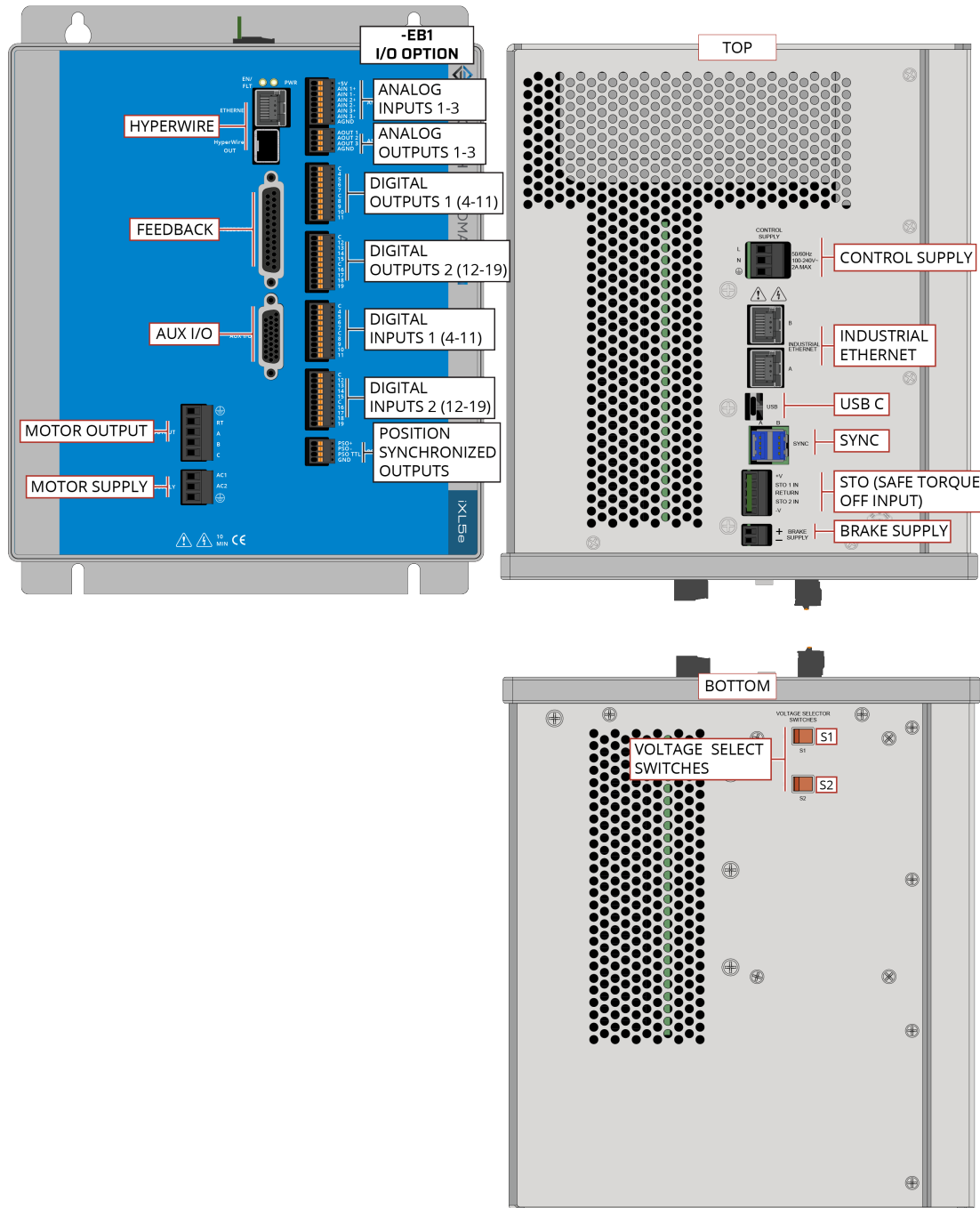
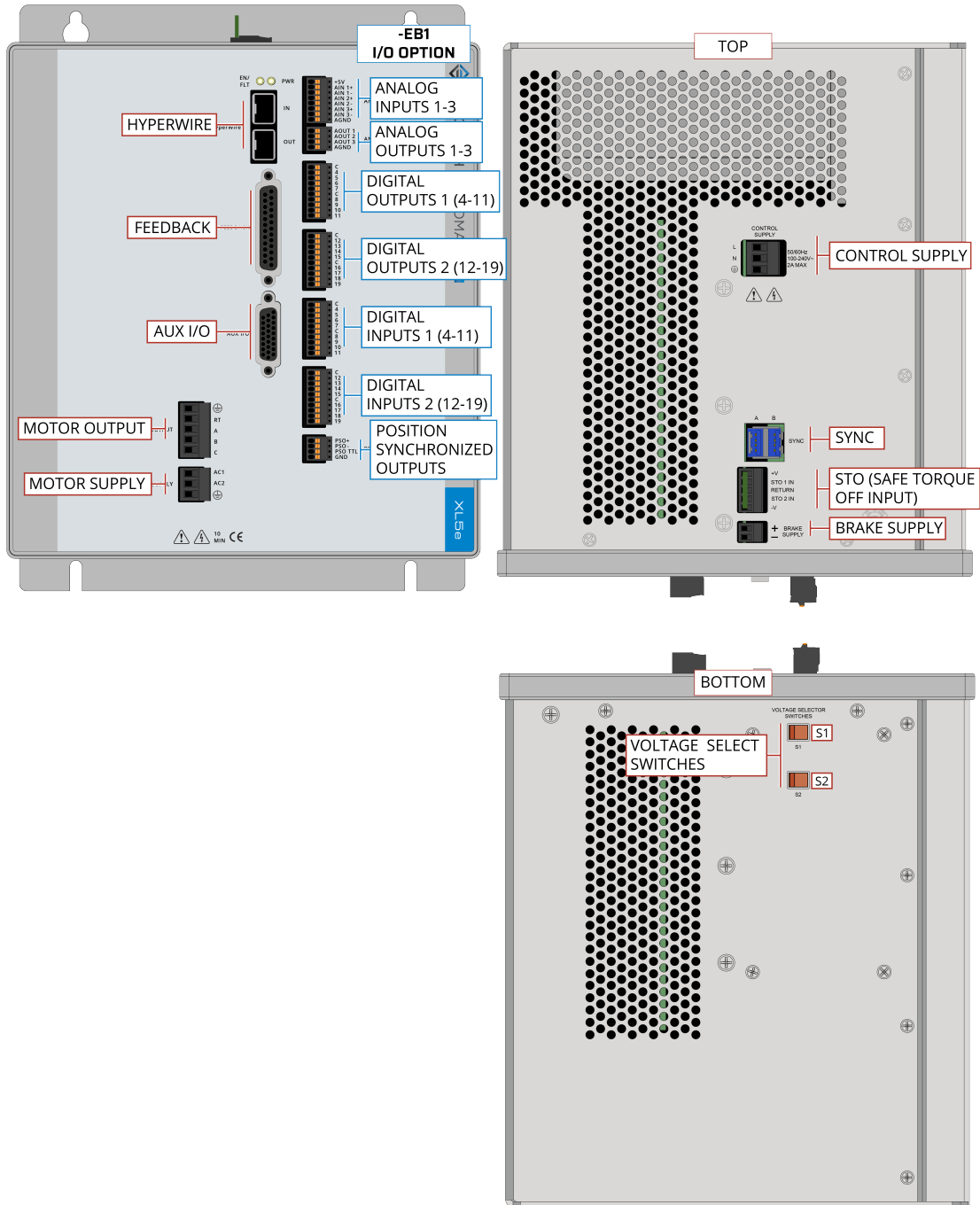

Figure 1-2: XL5e High Performance Linear Amplifier



1.1. Feature Summary

- 100 - 240 VAC control supply input ([Section 2.1.1.](#))
- 20 kHz Servo Loop Update Rate
- Factory-configured motor supply AC input ([Section 2.1.2.](#))
- Line driver square wave quadrature encoder input for position and velocity feedback ([Section 2.3.1.](#))
- Absolute Encoder support on the Feedback Connector ([Section 2.3.1.2.](#))
- One fail-safe brake output ([Section 2.3.6.](#))
- Two STO sense inputs ([Section 2.4.](#))
- Line driver square wave auxiliary quadrature encoder input or output for PSO ([Section 2.5.1.](#))
- Absolute Encoder support on the Auxiliary I/O Connector ([Section 2.5.1.2.](#))
- Four digital user outputs ([Section 2.5.3.](#))
- Six digital user inputs
 - Four Digital Inputs ([Section 2.5.4.](#))
 - Two High-Speed Inputs ([Section 2.5.5.](#))
- One 16-bit analog output (± 10 V) ([Section 2.5.6.](#))
- One 16-bit differential analog input (± 10 V) ([Section 2.5.7.](#))
- Position Synchronized Outputs (PSO):
 - Generate outputs synchronized to feedback positioning ([Section 2.5.2.](#))
 - Part-Speed PSO Firing:
 - One to three axes (one axis is the default)
 - Part-Speed PSO commands high-speed, low-latency output pulses based on the commanded vector velocity. Refer to the online help for more information.
 - Multi-Axis PSO Tracking: To track multiple axes...
 - with Aerotech drives, use the Sync Ports ([Section 2.8.](#))
 - with non-Aerotech drives and square wave encoder signals, use the Auxiliary Encoder connector ([Section 2.5.](#))
 - with non-Aerotech drives and sine wave (-MX2 or -MX3 option required) or square wave encoder signals, use the Primary Feedback connector ([Section 2.3.](#))
- One HyperWire communication channel ([Section 2.7.](#))
- One 10/100/1000 BASE-T Ethernet Port (**iXL5e Only**)
- One USB 2.0 Type C Port (**iXL5e Only**)
- Two 100 BASE-T Industrial Ethernet Ports (**iXL5e Only**)

1.2. Ordering Options

Table 1-1: Example Order and Ordering Options

Example	
Automation1-iXL5e-20-VB4-VL1-EB1-MX2-PSO2	
Options	
Drive	
XL5e	Enhanced, High-Performance Linear Servo Drive
iXL5e	Enhanced, High-Performance Linear Servo Drive with Motion Controller
Peak Current (Section 1.4.)	
-10	10 A Peak
-20	20 A Peak
Bus Voltage	
-VB4	±40 VDC Bus Voltage (available for -10 or -20 option boards)
-VB5	±60 VDC Bus Voltage (available for -10 option board)
-VB6	±80 VDC Bus Voltage (available for -10 option board)
Input Line Voltage	
-VL1	120 VAC
-VL2	240 VAC
-VL3	100 VAC
-VL4	200 VAC
Expansion Board (Chapter 3)	
-EB0	No expansion board
-EB1	I/O expansion board <ul style="list-style-type: none"> • Three 16-bit analog outputs (±10 V) • Three 16-bit differential analog inputs (±10 V) • 16 digital logic inputs (5 - 24 VDC), may be connected in current sourcing or sinking mode • 16 digital logic outputs (5 - 24 VDC), user defined as current sourcing or sinking • Digital logic laser firing (PSO) output
Multiplier (Section 2.3.1.3.)	
-MX0	No encoder multiplier
-MX2	Interpolation circuit allowing for analog sine wave input on the primary encoder channel with an interpolation factor of 65,536
-MX3	Interpolation circuit allowing for analog sine wave input on the primary encoder channel with an interpolation factor of 65,536 and an auxiliary encoder channel with an interpolation factor of 16,384.
PSO (Section 2.5.2.)	
-PSO1	One-axis PSO firing (includes One-axis Part-Speed PSO)
-PSO2	Two-axis PSO firing (includes Two-axis Part-Speed PSO)
-PSO3	Three-axis PSO firing (includes Three-axis Part-Speed PSO)
-PSO5	Two-axis Part-Speed PSO firing, which uses the PSO firing circuit based off of the commanded vector velocity of up to 2 axes (includes One-Axis PSO).
-PSO6	Three-axis Part-Speed PSO firing, which uses the PSO firing circuit based off of the commanded vector velocity of 3 or more axes (includes One-Axis PSO).

1.3. Functional Block Diagram

The block diagram that follows shows a summary of the connector signals.

Figure 1-3: Functional Diagram

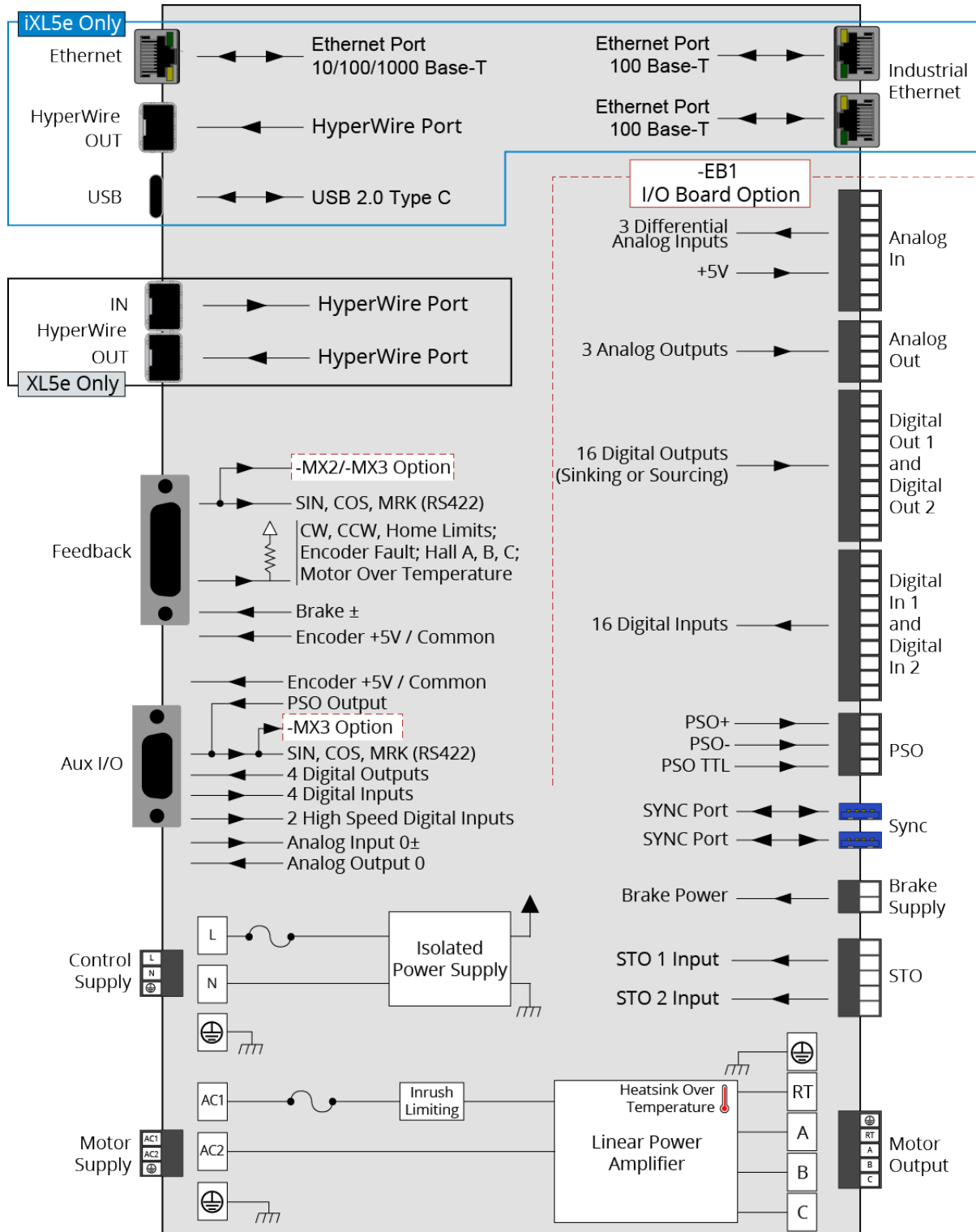

1.4. Electrical Specifications

Table 1-2: Linear Amplifier Specifications

	-10-VB4 Option	-20-VB4 Option	-10-VB5 Option	-10-VB6 Option
Nominal Motor Bus Voltage	±40 V	±40 V	±60 V	±80 V
Peak Output Current	10 A _{PK}	20 A _{PK}	10 A _{PK}	10 A _{PK}
Continuous Output Current @ 25°C ⁽¹⁾⁽²⁾	5 A _{PK} / 5 A _{PK}	5 A _{PK} / 9 A _{PK}	3.2 A _{PK} / 6 A _{PK}	2.5 A _{PK} / 4.5 A _{PK}
Continuous Output Current @ 35°C ⁽¹⁾⁽²⁾	4 A _{PK} / 5 A _{PK}	4 A _{PK} / 8 A _{PK}	2 A _{PK} / 5.5 A _{PK}	2 A _{PK} / 4 A _{PK}
Maximum Continuous Total Power Dissipation ⁽²⁾⁽³⁾⁽⁴⁾	340 W / 585 W			
Peak Amplifier Power Dissipation per phase ⁽⁵⁾	1200 W			
Effective Heatsink Thermal Resistance ⁽²⁾	.15°C/W / .085°C/W			
Maximum Transistor Temperature	75°C			
Time to reach maximum temperature at maximum continuous power	10 minutes			
Motor Supply	Input Frequency	50-60 Hz		
	Inrush current	68 A _{pk} @ 240 V		
	AC Line Voltage	AC Input (Switch Selectable): 100 VAC (90 - 112 VAC) 120 VAC (103 - 127 VAC) 200 VAC (180 - 224 VAC) 240 VAC (207 - 254 VAC)		
	Input current (maximum, continuous)	7 A _{RMS} @ 120 V / 3.5 A _{RMS} @ 240 V		
Control Supply	Input Frequency	50-60 Hz		
	Inrush current	68 A _{PK} @ 240 V		
	Input current (maximum, continuous)	.25 A _{rms}		
Current Loop Bandwidth	2500 Hz (software selectable)			
Minimum load resistance	0 Ω			
Minimum load inductance	0 H			
Modes of operation	Brushless, Brush, Stepper			
Protection Features	Peak current limit, Over temperature, RMS current limit, Dynamic power limit (SOA)			
Encoder Supply	5 V @ 500 mA			
<p>(1) AC or DC motor type with a 0 Ω winding resistance assumed.</p> <p>(2) The first value is for a stationary AC or DC motor. The second value is for a moving AC motor.</p> <p>(3) De-rate at temperatures above 25°C ambient.</p> <p>(4) Amplifier power dissipation is calculated as $(V_{bus} - V_{out}) \cdot I_{out}$ for each phase. A 40B configuration that drives 1 A into 0 Ω results in 40 W of power dissipation in the amplifier.</p> <p>(5) The XL5e amplifier has peak power-limiting circuitry to protect itself from damage. The Power Limiting bit in the Drive Status word indicates if this has occurred.</p>				

1.4.1. System Power Requirements

The following equations can be used to determine total system power requirements. The actual power required from the mains supply will be the combination of actual motor power (work), motor resistance losses, and efficiency losses in the power electronics or power transformer. For 3-phase brushless motors:

Linear Amplifier Types

$$\text{Power Input [W]} = \text{MotorCurrent [A}_{pk}] \cdot \text{TotalBusVoltage [V}_{dc}] \cdot 3/2$$

NOTES

A_{pk} = Ampere peak

V_{dc} = Volt DC

1.4.2. Real-Time Clock Requirements (iXL5e Only)

The drive has an internal real-time clock that is used to time-stamp logged data. The clock is powered by an internal capacitor when the control supply is not connected to the drive. When the capacitor is fully charged, it will power the clock for 17.5 days.

If the capacitor is fully discharged, the time on the drive is not reliable. To reinitialize the real-time clock, you must:

- Connect the drive to the control supply. It will take 36 minutes to fully charge the capacitor.
- Connect the drive to the Automation1 Studio and reprogram the real-time clock.

The capacitor charges exponentially with a 7.2 minute time constant. Apply the control supply to charge the capacitor. To achieve the maximum 17.5 days of real-time clock operation in the absence of the control supply, the capacitor must be charged for 36 minutes. If the capacitor is not fully charged when the control supply is lost, the real-time clock will not last the entire 17.5 days on backup capacitor power.

1.5. Mechanical Specifications

1.5.1. Mounting and Cooling

The drive must be installed in an enclosed control cabinet suitable for installation of power equipment. A minimum enclosure rating of IP54 is required to comply with safety standards. Make sure that there is sufficient clearance surrounding the drive for free airflow and for the routing of cables and connections. Consideration for items such as line reactors, line filters, and motor chokes or inductance should be made during the initial cabinet design phase.



IMPORTANT: Airflow Requirements

- The amount of airflow required to keep the drive temperature within a sufficient range is dependent on the operating conditions. You could be required to supply additional airflow to the drive.
- There are fans on the left and right sides of the unit and perforations on the top and bottom of the unit. The left side fan blows air into the power amplifier heat sink. The right side fan cools the logic hardware. The forced air exits through the top and bottom perforations.

Table 1-3: Mounting Specifications

		iXL5e/XL5e
Customer-Supplied Enclosure		IP54 Compliant
Weight		11.35 kg
Mounting Hardware		M5 [#10] screws (four locations, not included)
Mounting Orientation		Vertical (typical)
Dimensions		Refer to Section 1.5.2. Dimensions
Minimum Clearance	Airflow	~25 mm
	Connectors	~100 mm
Operating Temperature		Refer to Section 1.6. Environmental Specifications
Drive IP Rating		IP20

1.5.2. Dimensions



IMPORTANT: iXL5e and XL5e dimensions are the same. iXL5e is shown.

Figure 1-4: Dimensions

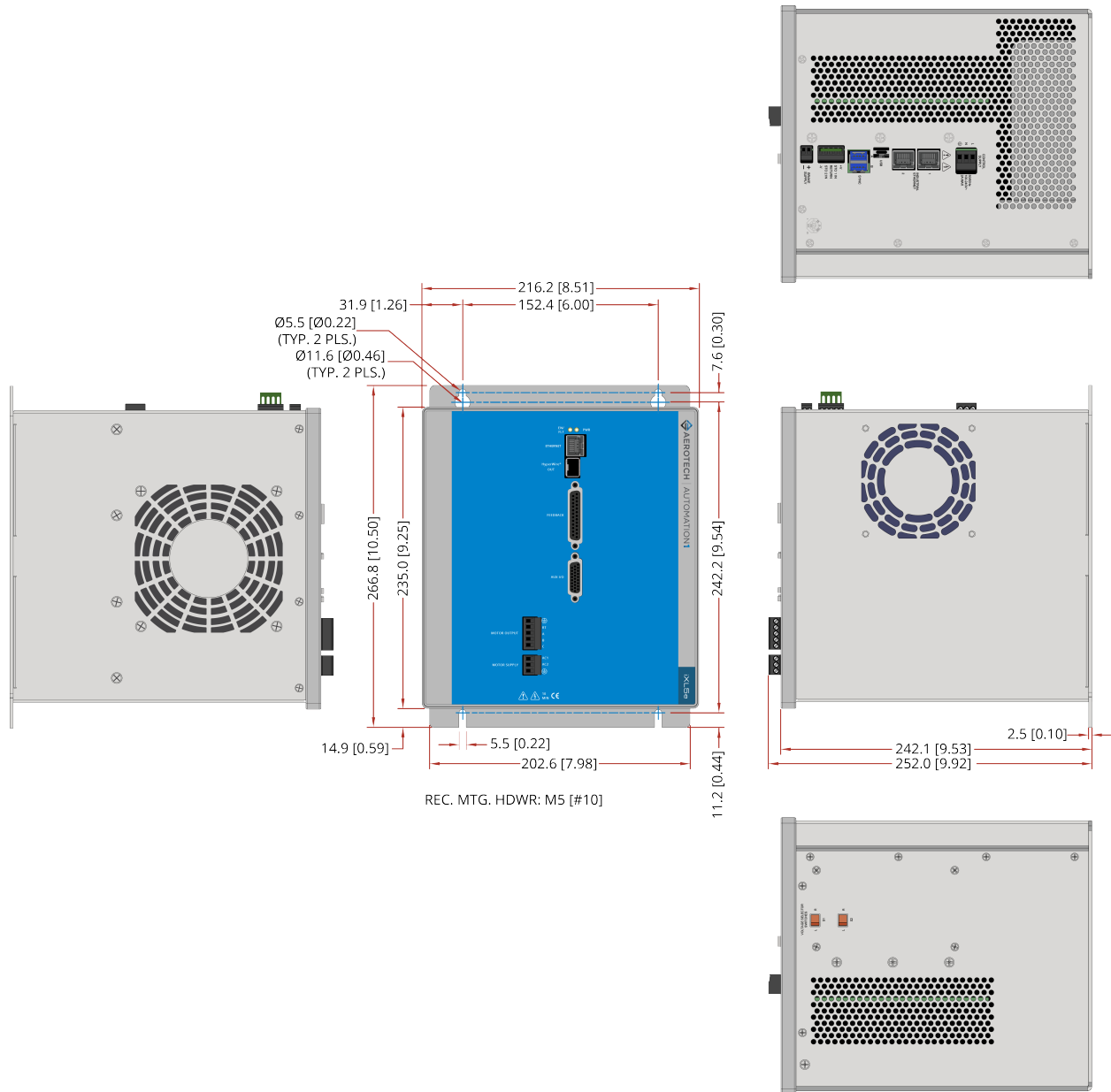



IMPORTANT: iXL5e-EB1 and XL5e-EB1 dimensions are the same. iXL5e-EB1 is shown.

Figure 1-5: Dimensions [-EB1]

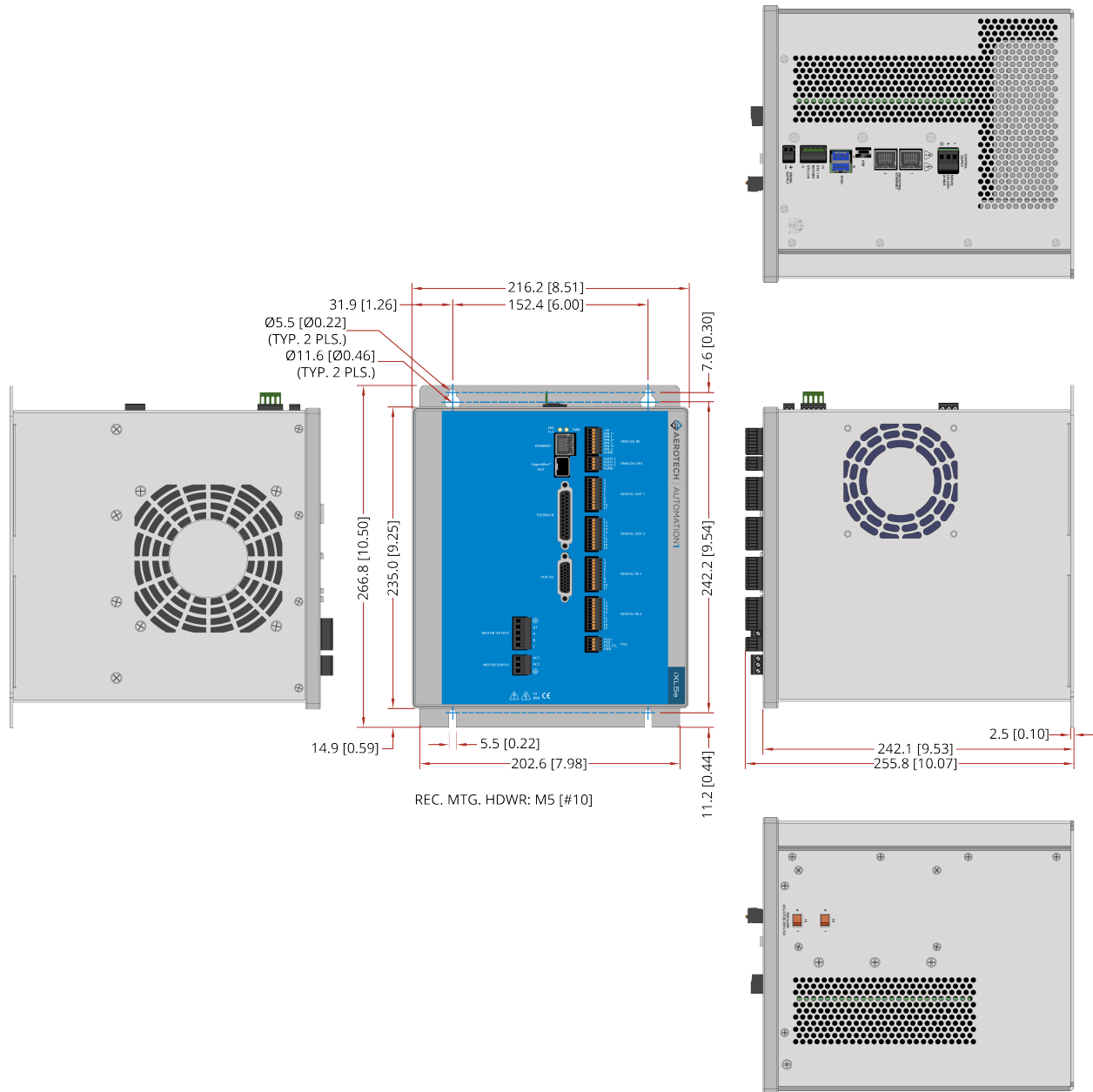

1.6. Environmental Specifications

The environmental specifications are listed below.

Table 1-4: Environmental Specifications

Temperature	Operating: 0 °C to 40 °C (32 °F to 104 °F)
	Maximum Surrounding Air: 40 °C (104 °F)
	Storage: -30 °C to 85 °C (-22 °C to 185 °F)
Humidity Non-condensing	The maximum relative humidity is 80% for temperatures that are less than 31 °C and decreases linearly to 50% relative humidity at 40 °C.
Operating Altitude	0 m to 2,000 m (0 ft to 6,562 ft) above sea level.
Pollution	Pollution Degree 2 Typically only nonconductive pollution occurs.
Operation	Use only indoors

1.7. Drive and Software Compatibility

This table shows the available drives and which version of the software first supported each drive. In the **Last Software Version** column, drives that show a specific version number are not supported after that version.

Table 1-5: Drive and Software Compatibility

Drive Type	First Software Version	Last Software Version
iXL5e	2.1.0	Current
XL5e	1.2.0	Current

This page intentionally left blank.

Chapter 2: Installation and Configuration

The sections in this chapter include details on how to set up the electrical and safety components of your system. Obey all safety warnings, including those in [Safety Procedures and Warnings](#).

2.1. Input Power Connections

The drive has two AC input power connectors. One connector is for control power and the other connector is for motor power. For a full list of electrical specifications, refer to [Section 1.4](#).

2.1.1. Control Supply Connector



DANGER: Shock and Fire Hazard



Electrical wiring must be designed and installed in accordance with local electrical safety regulations to prevent the risk of fire and electrical shock.

The Control Supply input supplies power to the communications and logic circuitry of the drive. The **L** input is connected to an internal fuse. Refer to [Table 5-4](#) for the internal fuse value and part number. The **N** input is not connected to an internal fuse. An external fuse will be required if **N** is not connected to Neutral.

The Control Supply contains an internal filter but you could be required to add an external filter for CE compliance. Install the external filter module as close as possible to the drive. Use a Schaffner FN2080 filter, an Aerotech UFM-ST noise filter module, or equivalent device.

Figure 2-1: Control Supply Connections

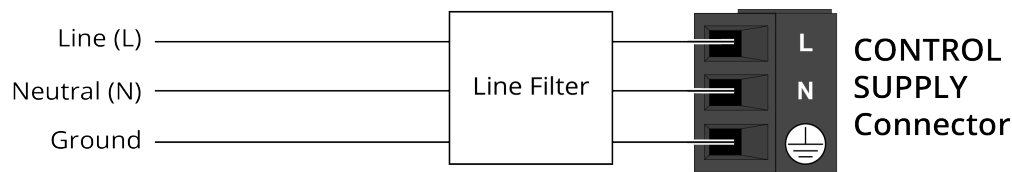

Table 2-1: Control Supply Connector Pinout

Pin	Description
L	Line (L): 100-240 VAC Control Power Input
N	Neutral (N) or 100-240 VAC Control Power Input with external fuse
	Protective Ground

Table 2-2: Control Supply Mating Connector Ratings

Specification		Description
Type		3-Pin Terminal Block
Part Numbers		Aerotech: ECK02388 Phoenix: 1756272
Conductor Cross Section	One conductor, stranded with ferrule and plastic sleeve	14...22 AWG (0.25...2.5 mm ²)
	Two conductors (same cross-section), stranded, twin ferrule with plastic sleeve	16...20 AWG (0.5...1.5 mm ²)
Tightening Torque		0.5...0.6 N·m
Conductor Insulation Strip Length		7 mm (0.25 in)
(1) Refer to the manufacturer website for additional information.		

2.1.2. Motor Supply Connector



DANGER: Shock and Fire Hazard!

Electrical wiring must be designed and installed in accordance with local electrical safety regulations to prevent the risk of fire and electrical shock.

Motor power is applied to the **AC1** and **AC2** terminals of the Motor Supply connector. The **AC1** input is internally fused but the **AC2** input is not. An external fuse is required if **AC2** is not connected to Neutral. Refer to [Table 5-4](#) for the internal fuse part numbers.

Refer to Appendix B for information on how to change the factory-configured motor input voltage.



WARNING: Do not connect a voltage that exceeds the configured voltage. This will cause an internal fuse to open and could cause damage to components that are configured for ± 60 VDC or ± 80 VDC motor voltage options.



WARNING: Verify that all ground connections are installed correctly before you apply power to the iXL5e/XL5e.

Figure 2-2: Motor Supply Connections

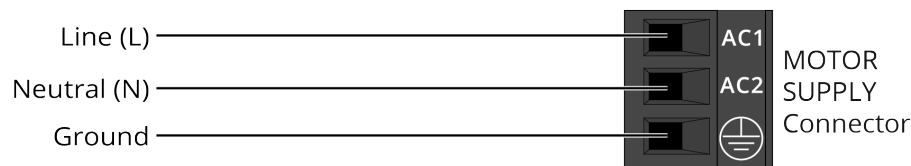

Table 2-3: Motor Supply Connector Pinout

Pin	Description
AC1	Factory-Configure Motor Power Input
AC2	Motor Power Input Common
	Protective Ground - 2.5 mm ² (14 AWG) minimum conductor size

Table 2-4: Motor Supply Mating Connector Ratings

Specification		Description
Type		3-Pin Terminal Block
Part Numbers		Aerotech: ECK02388 Phoenix: 1756272
Conductor Cross Section	One conductor, stranded with ferrule and plastic sleeve	14...22 AWG (0.25...2.5 mm ²)
	Two conductors (same cross-section), stranded, twin ferrule with plastic sleeve	16...20 AWG (0.5...1.5 mm ²)
Tightening Torque		0.5...0.6 N·m
Conductor Insulation Strip Length		7 mm (0.25 in)

(1) Refer to the manufacturer website for additional information.

2.2. Motor Power Output Connector



DANGER: Before you do maintenance to the equipment, disconnect the electrical power. Wait at least ten (10) minutes after removing the power supply before doing maintenance or an inspection. Otherwise, there is the danger of electric shock.

The drive can be used to drive the following motor types:

- Brushless (refer to [Section 2.2.1.](#))
- DC Brush (refer to [Section 2.2.2.](#))
- Stepper (refer to [Section 2.2.3.](#))

For a complete list of electrical specifications, refer to [Section 1.4.](#)



DANGER: Shock and Fire Hazard



Electrical wiring must be designed and installed in accordance with local electrical safety regulations to prevent the risk of fire and electrical shock.

The 5-pin terminal block style motor output connector is located on the front panel.

Table 2-5: Motor Power Output Connector Pinout

Pin	Description	Connector
	Earth Ground to Motor	
RT	Brushless (No Connection) DC Brush - (Half Bus Voltage) Stepper Return	
A	Brushless Phase A Motor Lead DC Brush + Stepper	
B	Brushless Phase B Motor Lead DC Brush (No Connection) Stepper	
C	Brushless Phase C Motor Lead DC Brush - (Full Bus Voltage) Stepper (No Connection)	

Table 2-6: Motor Power Output Mating Connector Ratings

Specification	Description
Type	5-Pin Terminal Block
Part Numbers	Aerotech: ECK02434
	Phoenix: 1756311
Conductor Cross Section	One conductor, stranded with ferrule and plastic sleeve 14...22 AWG (0.25...2.5 mm ²)
	Two conductors (same cross-section), stranded, twin ferrule with plastic sleeve 16...20 AWG (0.5...1.5 mm ²)
Tightening Torque	0.5...0.6 N·m
Conductor Insulation Strip Length	7 mm (0.25 in)
(1) Refer to the manufacturer website for additional information.	

2.2.1. Brushless Motor Connections

The configuration in [Figure 2-3](#) shows a typical brushless motor connection.

Figure 2-3: Brushless Motor Configuration

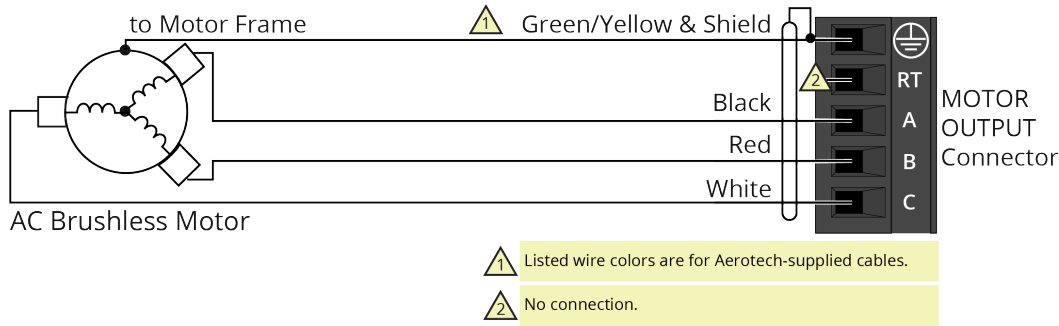

Table 2-7: Wire Colors for Aerotech-Supplied Brushless Motor Cables

Pin	Wire Color Set 1 ⁽¹⁾	Wire Color Set 2	Wire Color Set 3	Wire Color Set 4
⊕	Green/Yellow & Shield ⁽²⁾	Green/Yellow & Shield	Green/Yellow & Shield	Green/Yellow & Shield
A	Black	Blue & Yellow	Black #1	Black & Brown
B	Red	Red & Orange	Black #2	Red & Orange
C	White	White & Brown	Black #3	Violet & Blue

(1) Wire Color Set #1 is the wire set typically used by Aerotech.
 (2) "&" indicates two wires (Red & Orange); "/" indicates a single wire (Green/White).

Brushless motors are commutated electronically by the controller. The use of Hall effect devices for commutation is recommended.

The controller requires that the Back-EMF of each motor phase be aligned with the corresponding Hall-effect signal. To ensure proper alignment, motor, Hall, and encoder connections should be verified using one of the following methods: *powered*, through the use of a test program; or *unpowered* using an oscilloscope. Both methods will identify the A, B, and C Hall/motor lead sets and indicate the correct connections to the controller. Refer to [Section 2.2.1.1](#) for powered motor phasing or [Section 2.2.1.2](#) for unpowered motor and feedback phasing.

For Aerotech-supplied systems, the motor, encoder and Hall sensors are correctly configured and connection adjustments are not necessary.

2.2.1.1. Brushless Motor Powered Motor and Feedback Phasing

Observe the state of the encoder and Hall-effect device signals in the Diagnostics section of the Status Utility.

Table 2-8: Hall Signal Diagnostics

Hall-Signal Status	Definition
--	0 V or logic low
ON	5 V or logic high

Figure 2-4: Positive Motor Direction

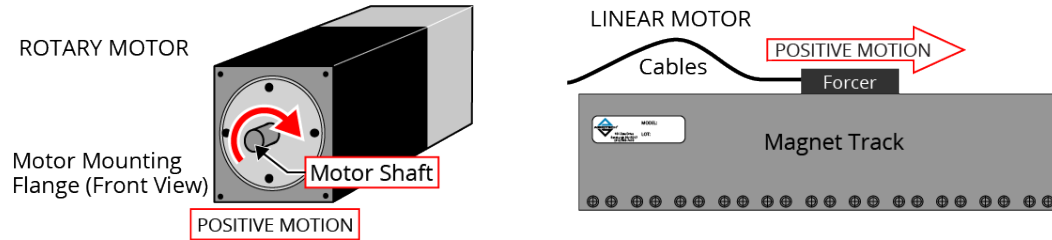

Figure 2-5: Encoder and Hall Signal Diagnostics

Figure 2-5 shows a screenshot of the 'Diagnostics' section in a software utility. The 'Polling rate' is set to 'Medium'. The left sidebar shows a tree view with 'Diagnostics' selected. The main table displays diagnostic data for axes X, Y, Z, and U. The 'Status' section includes items like Position Feedback, Calibration, and Camming/Gearing. The 'Hardware' section includes Enable, CW, CCW, Home, Marker, Hall A, Hall B, Hall C, ESTOP, and Brake. Red boxes highlight the 'Diagnostics' menu item, the 'Status' section header, the 'Position Feedback' row, and the 'Hall A', 'Hall B', and 'Hall C' rows. The 'Hall A', 'Hall B', and 'Hall C' status values are shown as '--'.

Item	X	Y	Z	U
Status				
Position Feedback	000000000000	000000000000	000000000000	000000000000
Position Calibration All	000000000000	000000000000	000000000000	000000000000
Position Camming/Gearing	000000000000	000000000000	000000000000	000000000000
Primary Feedback	000000000000	000000000000	000000000000	000000000000
Auxiliary Feedback	000000000000	000000000000	000000000000	000000000000
Gantry Marker Difference	0.0000	0.0000	0.0000	0.00
Analog Input 0	0.0000	0.0000	0.0000	0.00
Analog Input 1	0.0000	0.0000	0.0000	0.00
Analog Input 2	0.0000	0.0000	0.0000	0.00
Analog Input 3	0.0000	0.0000	0.0000	0.00
Digital Input 15:0	0000 0000 0000 0000	0000 0000 0000 0000	0000 0000 0000 0000	0000 0000 0000 00
Digital Input 31:16	0000 0000 0000 0000	0000 0000 0000 0000	0000 0000 0000 0000	0000 0000 0000 00
Digital Output 15:0	0000 0000 0000 0000	0000 0000 0000 0000	0000 0000 0000 0000	0000 0000 0000 00
Digital Output 31:16	0000 0000 0000 0000	0000 0000 0000 0000	0000 0000 0000 0000	0000 0000 0000 00
Average Velocity Feedback	000000000000	000000000000	000000000000	000000000000
Current Feedback	0.0000	0.0000	0.0000	0.00
Transition Offset Errors	0	0	0	
Hardware				
Enable	--	--	--	
CW	--	--	--	
CCW	--	--	--	
Home	--	--	--	
Marker	--	--	--	
Hall A	--	--	--	
Hall B	--	--	--	
Hall C	--	--	--	
ESTOP	--	--	--	
Brake	--	--	--	

2.2.1.2. Brushless Motor Unpowered Motor and Feedback Phasing

Disconnect the motor from the controller and connect the motor in the test configuration shown in [Figure 2-6](#). This method will require a two-channel oscilloscope, a 5V power supply, and six resistors (10,000 ohm, 1/4 watt). All measurements should be made with the probe common of each channel of the oscilloscope connected to a neutral reference test point (TP4, shown in [Figure 2-6](#)). Wave forms are shown while moving the motor in the positive direction.

Figure 2-6: Brushless Motor Phasing Oscilloscope Example

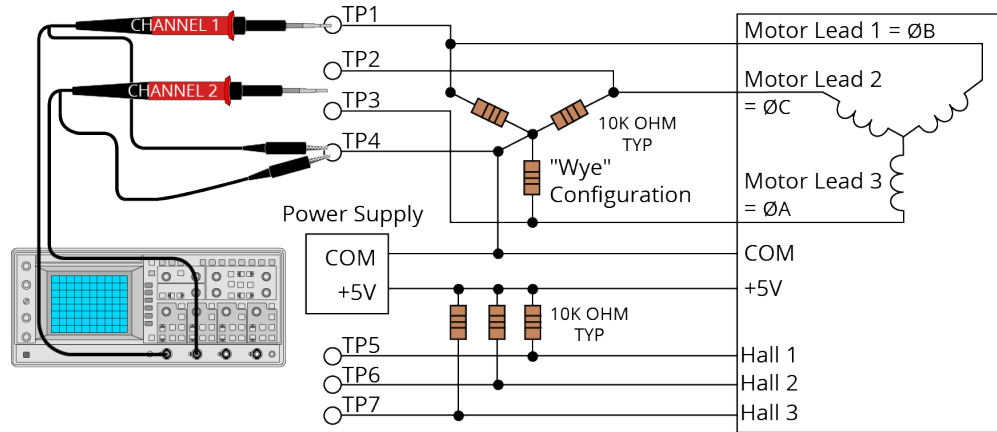

With the designations of the motor and Hall leads of a third party motor determined, the motor can now be connected to an Aerotech system. Connect motor lead A to motor connector A, motor lead B to motor connector B, and motor lead C to motor connector C. Hall leads should also be connected to their respective feedback connector pins (Hall A lead to the Hall A feedback pin, Hall B to Hall B, and Hall C to Hall C). The motor is correctly phased when the Hall states align with the Back EMF as shown in [Figure 2-7](#). Use the CommutationOffset parameter to correct for Hall signal misalignment.

Figure 2-7: Brushless Motor Phasing Goal

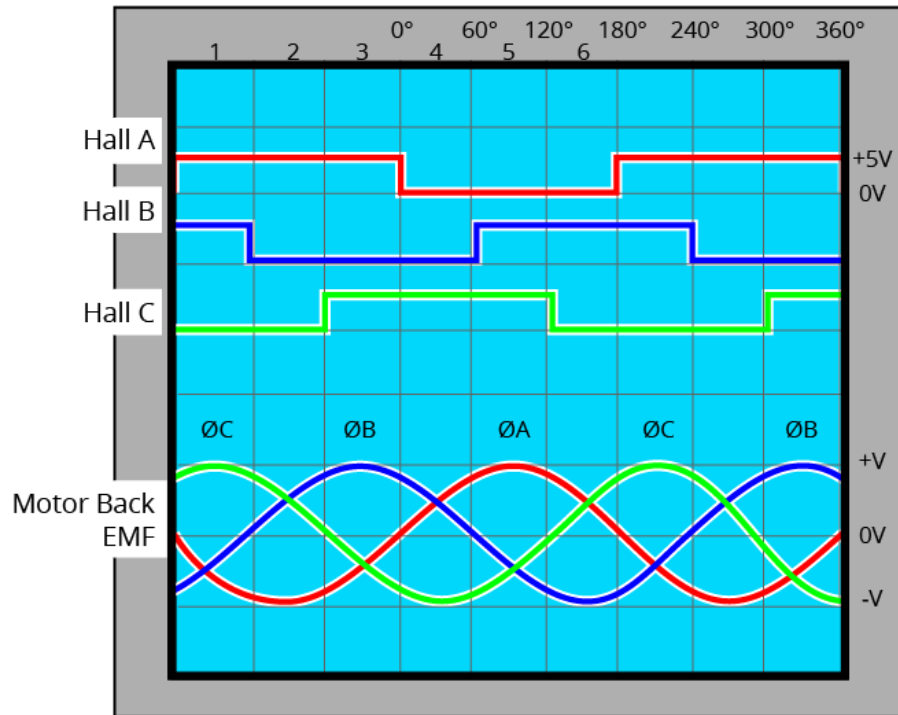

2.2.2. DC Brush Motor Connections

The configuration shown in [Figure 2-8](#) is an example of a typical DC brush motor connection. Refer to [Section 2.2.2.1.](#) for information on motor phasing.

When you connect the motor between amplifier phases A and C, it will produce twice the nominal bus voltage across the motor. This is because phase C will generate the same voltage as phase A but with opposite polarity. To generate the nominal bus voltage, connect the motor between Phase A and RT. RT is the 0 V return path for the motor power supply.

Use the lowest voltage configuration possible to minimize heat generation in the amplifier.

Figure 2-8: DC Brush Motor Configuration

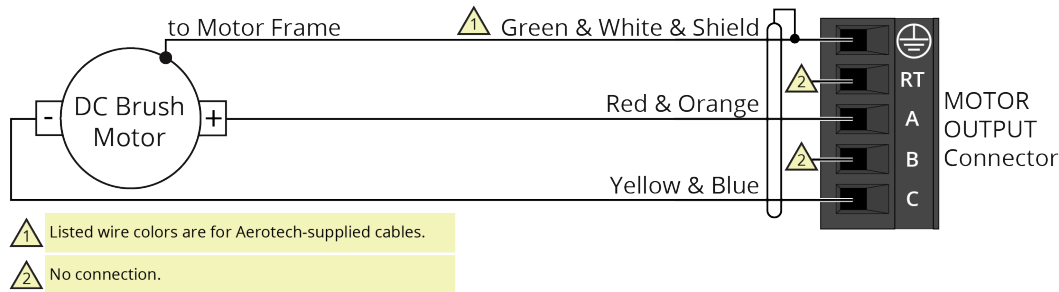

Figure 2-9: DC Brush Motor Configuration

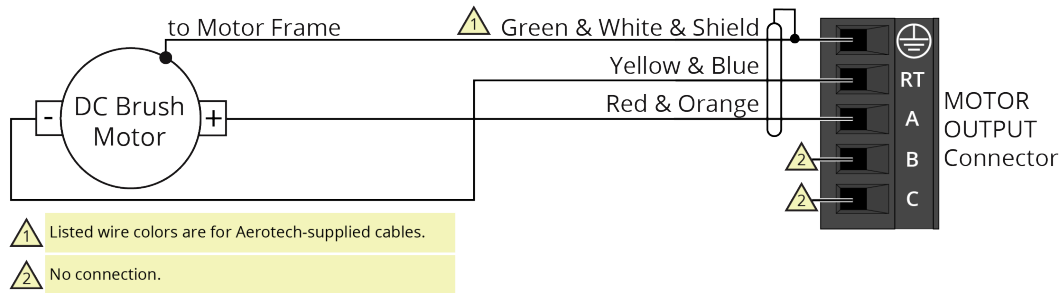

Table 2-9: DC Brush Voltage Output Configuration

Connection	XL5e 20-VB4	XL5e10-VB4	XL5e10-VB5	XL5e10-VB6
A to C	80 V	80 V	120 V	160 V
A to RT	40 V	40 V	60 V	80 V

Table 2-10: Wire Colors for Aerotech-Supplied DC Brush Motor Cables

Pin	Wire Color Set 1 ⁽¹⁾	Wire Color Set 2	Wire Color Set 3
	Green & White & Shield ⁽²⁾	Green/Yellow & Shield	Green/Yellow & Shield
A	Red & Orange	Red	Red & Orange
C	Yellow & Blue	Black	Yellow & Blue

(1) Wire Color Set #1 is the typical wire set used by Aerotech.
 (2) “&” (Red & Orange) indicates two wires; “/” (Green/White) indicates a single wire.

2.2.2.1. DC Brush Motor Phasing

A properly phased motor means that the positive motor lead should be connected to the $\emptyset A$ motor terminal and the negative motor lead should be connected to the $\emptyset C$ motor terminal. To determine if the motor is properly phased, connect a voltmeter to the motor leads of an un-powered motor:

1. Connect the positive lead of the voltmeter to the one of the motor terminals.
2. Connect the negative lead of the voltmeter to the other motor terminal.
3. Move or rotate the motor in the positive or clockwise (CW) direction by hand.

Figure 2-10: Positive Motor Direction

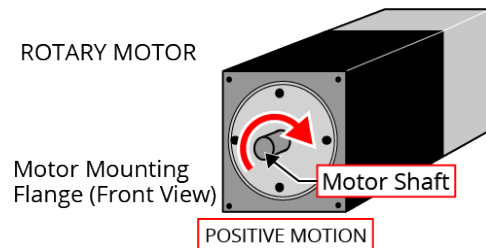

4. If the voltmeter indicates a negative value, swap the motor leads and move the motor by hand in the positive direction, again. When the voltmeter indicates a positive value, the motor leads have been identified.
5. Connect the motor lead from the positive lead of the voltmeter to the $\emptyset A$ motor terminal on the drive. Connect the motor lead from the negative lead of the voltmeter to the $\emptyset C$ motor terminal on the drive.

For Aerotech-supplied systems, the motor, encoder and Hall sensors are correctly configured and connection adjustments are not necessary.

2.2.3. Stepper Motor Connections

The configuration shown in [Figure 2-11](#) is an example of a typical stepper motor connection. Refer to [Section 2.2.3.1.](#) for information on motor phasing.

In this case, the effective motor voltage is half of the applied bus voltage. For example, an 80 V motor bus supply is needed to get 40 V across the motor.

Figure 2-11: Stepper Motor Configuration

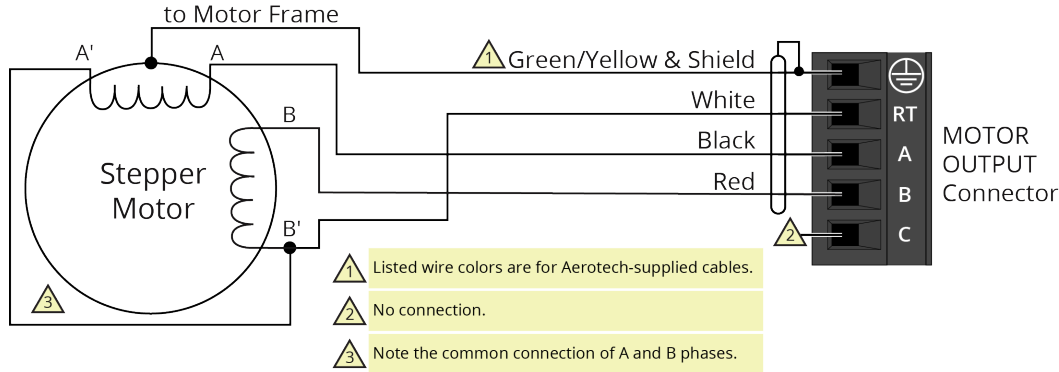

Table 2-11: Wire Colors for Aerotech-Supplied Stepper Motor Cables

Pin	Wire Color Set 1 ⁽¹⁾	Wire Color Set 2
⊕	Green/Yellow & Shield ⁽²⁾	Green/Yellow & Shield
A	Black	Brown
B	Red	Yellow
C	White	White & Red

(1) Wire Color Set #1 is the typical wire set used by Aerotech.
 (2) “&” (Red & Orange) indicates two wires; “/” (Green/White) indicates a single wire.

2.2.3.1. Stepper Motor Phasing

A stepper motor can be run with or without an encoder.

Without an Encoder: You do not need to phase the motor.

With an Encoder: Because the end of travel (EOT) limit inputs are relative to motor rotation, it is important to phase the motor.

Run a positive motion command. The motor is phased correctly if there is a positive scaling factor (determined by the ServoLoopSetup parameter) and the motor moves in a clockwise direction when you view the motor from the front mounting flange ([Figure 2-12](#)). If the motor moves in a counterclockwise direction, reverse the motor leads and re-run the command. After the motor has been phased, if you want to change the direction of positive motion, use the ReverseMotionDirection parameter.

Figure 2-12: Positive Motor Direction

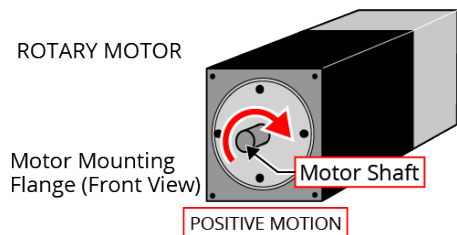

For Aerotech-supplied systems, the motor, encoder and Hall sensors are correctly configured and connection adjustments are not necessary.

2.2.4. Three Phase Stepper Motor Connections



IMPORTANT: This feature is only supported in Automation1 software version 2.2.0. or later.

The configuration shown in [Figure 2-13](#) is an example of a typical three phase stepper motor connection. Refer to [Section 2.2.4.1.](#) for information on motor phasing.

Figure 2-13: Three Phase Stepper Motor Configuration

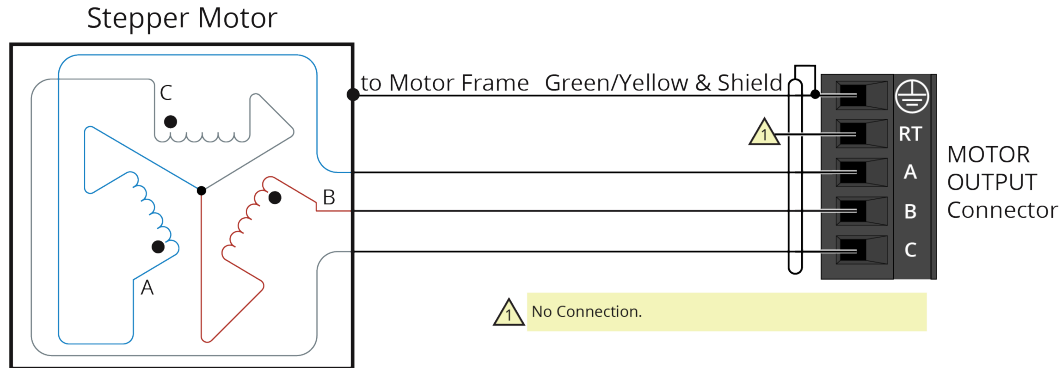

2.2.4.1. Stepper Motor Phasing

A three phase stepper motor can be run with or without an encoder.

Without an Encoder: You do not need to phase the motor.

With an Encoder: Because the end of travel (EOT) limit inputs are relative to motor rotation, it is important to phase the motor.

Run a positive motion command. The motor is phased correctly if there is a positive scaling factor (determined by the ServoLoopSetup parameter) and the motor moves in a clockwise direction when you view the motor from the front mounting flange ([Figure 2-14](#)). If the motor moves in a counterclockwise direction, reverse the motor leads and re-run the command. After the motor has been phased, if you want to change the direction of positive motion, use the ReverseMotionDirection parameter.

Figure 2-14: Positive Motor Direction

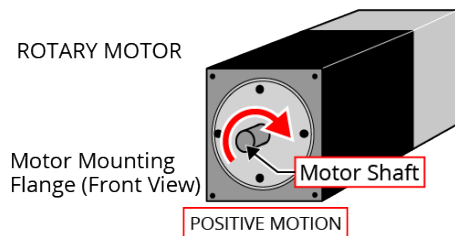

2.3. Feedback Connector

The connector pin assignment is shown in [Table 2-12](#) with detailed connection information in the following sections.

Table 2-12: Feedback Connector Pinout

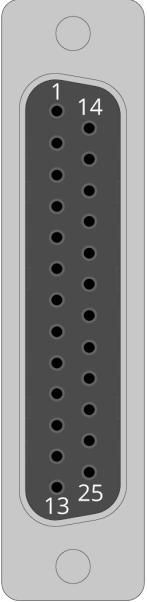
Pin #	Description	In/Out/Bi	Connector
1	Reserved	N/A	
2	Motor Over Temperature Thermistor	Input	
3	+5V Power ⁽¹⁾	Output	
4	Plug and Play Serial Data (for Aerotech stages only)	Bidirectional	
5	Hall-Effect Sensor B (brushless motors only)	Input	
6	Encoder Marker Reference Pulse -	Input	
	Absolute Encoder Clock -	Output	
7	Encoder Marker Reference Pulse +	Input	
	Absolute Encoder Clock +	Output	
8	Absolute Encoder Data -	Bidirectional	
9	Reserved	N/A	
10	Hall-Effect Sensor A (brushless motors only)	Input	
11	Hall-Effect Sensor C (brushless motors only)	Input	
12	Clockwise End of Travel Limit	Input	
13	Brake Output -	Output	
14	Encoder Cosine +	Input	
15	Encoder Cosine -	Input	
16	+5V Power ⁽¹⁾	Output	
17	Encoder Sine +	Input	
18	Encoder Sine -	Input	
19	Absolute Encoder Data+	Bidirectional	
20	Signal Common	Output	
21	Signal Common	Output	
22	Home Switch Input	Input	
23	Encoder Fault Input	Input	
24	Counterclockwise End of Travel Limit	Input	
25	Brake Output +	Output	

(1) The maximum combined current output is 500 mA.

Table 2-13: Feedback Mating Connector Ratings

Specification	25-Pin Solder Cup	Backshell
Aerotech Part Number	ECK00101	ECK00656
Amphenol Part Number ⁽¹⁾	DB25P064TXLF	17E-1726-2
Maximum Wire Size	20 AWG (0.5 mm ²)	N/A

(1) Refer to the manufacturer website for additional information.

2.3.1. Primary Encoder Inputs

The primary encoder inputs are accessible through the Feedback connector. Use the PrimaryFeedbackType parameter to configure the drive to accept an encoder signal type.

Square Wave encoder signals: [Section 2.3.1.1.](#)

Absolute encoder signals: [Section 2.3.1.2.](#)

Sine Wave encoder signals (as permitted by the multiplier option): [Section 2.3.1.3.](#)

Refer to [Section 2.3.1.4.](#) for encoder feedback phasing.

Refer to [Section 2.5.](#) for the auxiliary encoder on the Aux I/O connector.

Table 2-14: Multiplier Options

Option	Primary Encoder Accepts...	Auxiliary Encoder Accepts...
-MX0	Square Wave or Absolute encoders	Square Wave or Absolute encoders
-MX2	Sine Wave (high performance), Square Wave, or Absolute encoders	Square Wave or Absolute encoders
-MX3	Sine Wave (high performance), Square Wave, or Absolute encoders	Sine Wave (standard performance), Square Wave, or Absolute encoders



IMPORTANT: Physically isolate the encoder wiring from motor, AC power, and all other power wiring

Table 2-15: Primary Encoder Pins on the Feedback Connector

Pin #	Description	In/Out/Bi
3	+5V Power ⁽¹⁾	Output
6	Encoder Marker Reference Pulse -	Input
	Absolute Encoder Clock -	Output
7	Encoder Marker Reference Pulse +	Input
	Absolute Encoder Clock +	Output
8	Absolute Encoder Data -	Bidirectional
14	Encoder Cosine +	Input
15	Encoder Cosine -	Input
16	+5V Power ⁽¹⁾	Output
17	Encoder Sine +	Input
18	Encoder Sine -	Input
19	Absolute Encoder Data+	Bidirectional
20	Signal Common	Output
21	Signal Common	Output

(1) The maximum combined current output is 500 mA.

2.3.1.1. Square Wave Encoder (Primary)

The drive accepts RS-422 square wave encoder signals. The drive will generate a feedback fault if it detects an invalid signal state caused by an open or shorted signal connection. Use twisted-pair wiring for the highest performance and noise immunity.

Table 2-16: Square Wave Encoder Specifications

Specification	Value
Encoder Frequency	10 MHz maximum (25 ns minimum edge separation)
x4 Quadrature Decoding	40 million counts/sec

Figure 2-15: Square Wave Encoder Schematic (Feedback Connector)

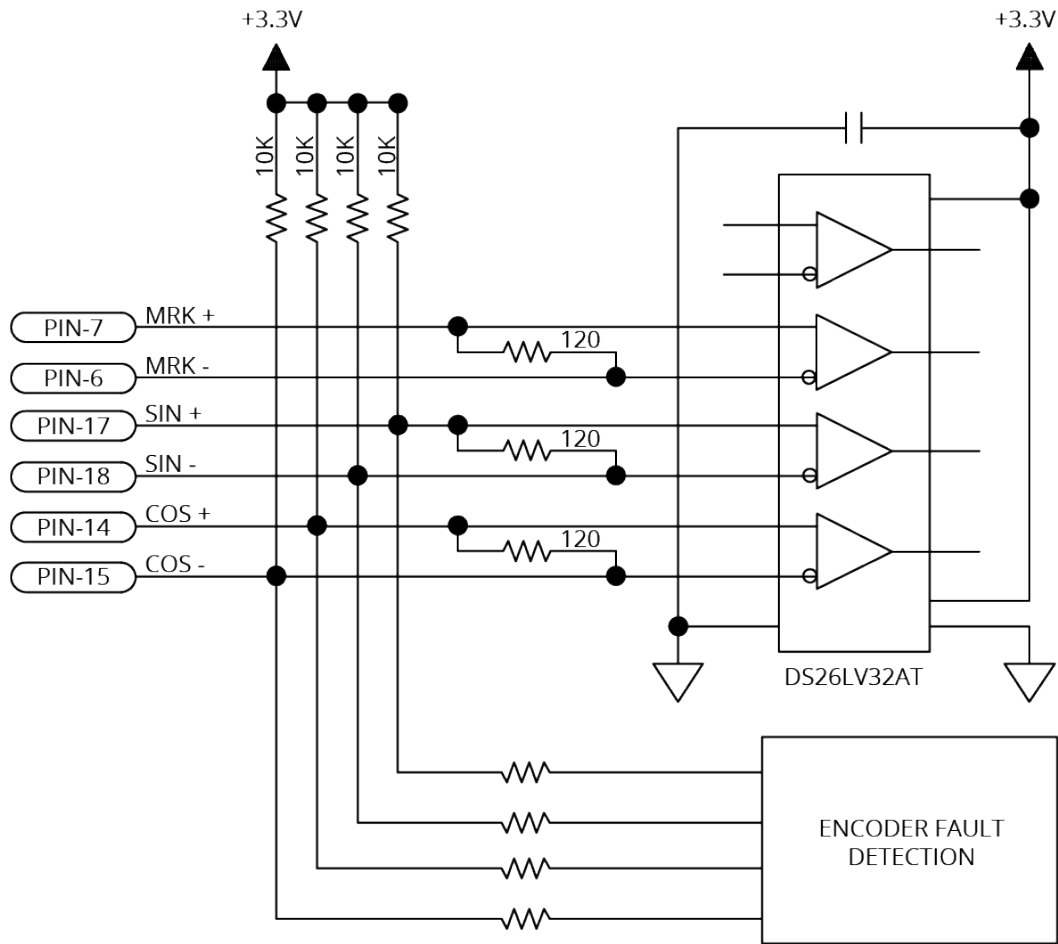

2.3.1.2. Absolute Encoder (Primary)

The drive retrieves absolute position data along with encoder fault information through a serial data stream from the absolute encoder. Use twisted-pair wiring for the highest performance and noise immunity. You cannot echo an absolute encoder signal.

Refer to [Figure 2-16](#) for the serial data stream interface.

Refer to the Help file for information on how to set up your EnDat, BiSS, or SSI absolute encoder parameters.

Table 2-17: Absolute Encoder Specifications

Specification	Value
Sampling Frequency	20 kHz
Maximum Reading Speed	Refer to your encoder data sheet.

Figure 2-16: Absolute Encoder Schematic (Feedback Connector)

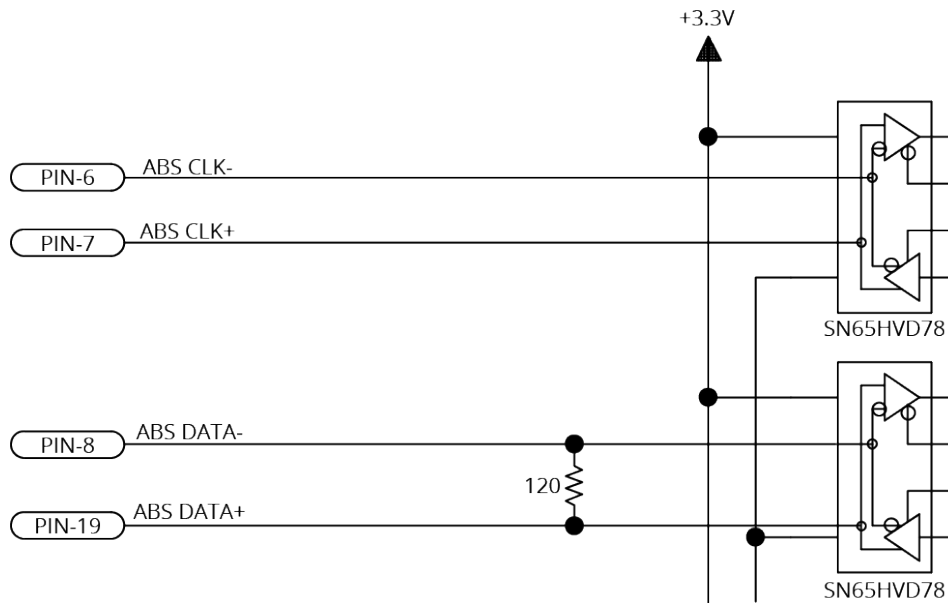

2.3.1.3. Sine Wave Encoder (Primary) [-MX2/-MX3 Option]

The Sine Wave Encoder option provides higher positioning resolution by subdividing the fundamental output period of the encoder into smaller increments. The amount of subdivision is specified by the PrimaryEncoderMultiplicationFactor parameter. Use Encoder Tuning to adjust the value of the gain, offset, and phase balance controller parameters to get the best performance. For more information, refer to the Help file.

High resolution or high-speed encoders can require increased bandwidth for correct operation. Use the High Speed Mode of the PrimaryEncoderMultiplierSetup parameter to enable the high bandwidth mode. Because this mode increases sensitivity to system noise, use it only if necessary.

The drive can generate emulated encoder signals. These signals can be output on the Auxiliary Encoder (AUX) connector, SYNC port connector, or used internally by the PSO. Refer to the EncoderDivider and PrimaryEmulatedQuadratureDivider parameters and the encoder output functions in the Help file for more information.

For the highest performance, use twisted pair double-shielded cable with the inner shield connected to signal common and the outer shield connected to frame ground. Do not join the inner and outer shields in the cable.

Table 2-18: Sine Wave Encoder Specifications

Specification	Value	
	Primary	Auxiliary
Input Frequency (max)	450 kHz, 2 MHz	450 kHz
Input Amplitude ⁽¹⁾	0.6 to 1.75 Vpk-pk	
Interpolation Factor (max)	-MX2	65,536
	-MX3	65,536
-MX2/-MX3 Primary Encoder Channel Interpolation Latency	800 nsec (analog input to quadrature output)	
Input Common Mode	1.5 to 3.5 VDC	
<small>(1) Measured as SIN(+) - SIN(-) or COS(+) - COS(-)</small>		

Figure 2-17: Sine Wave Encoder Phasing Reference Diagram

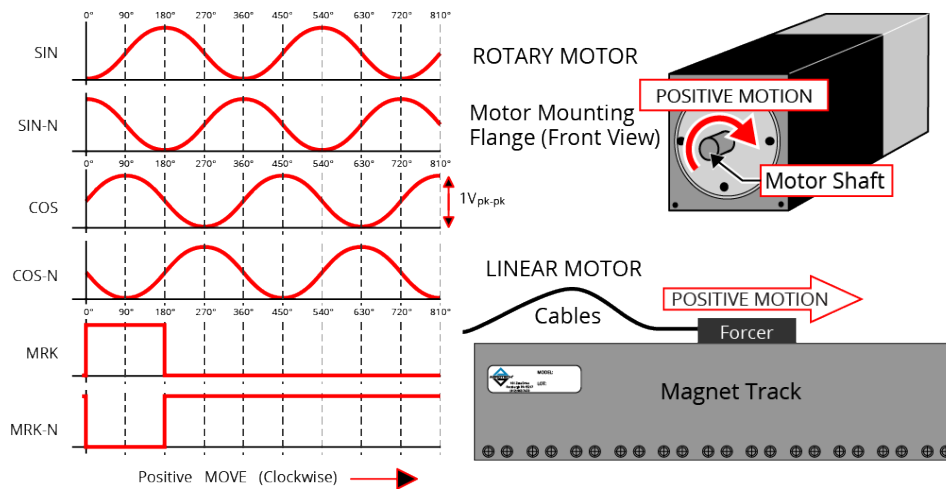
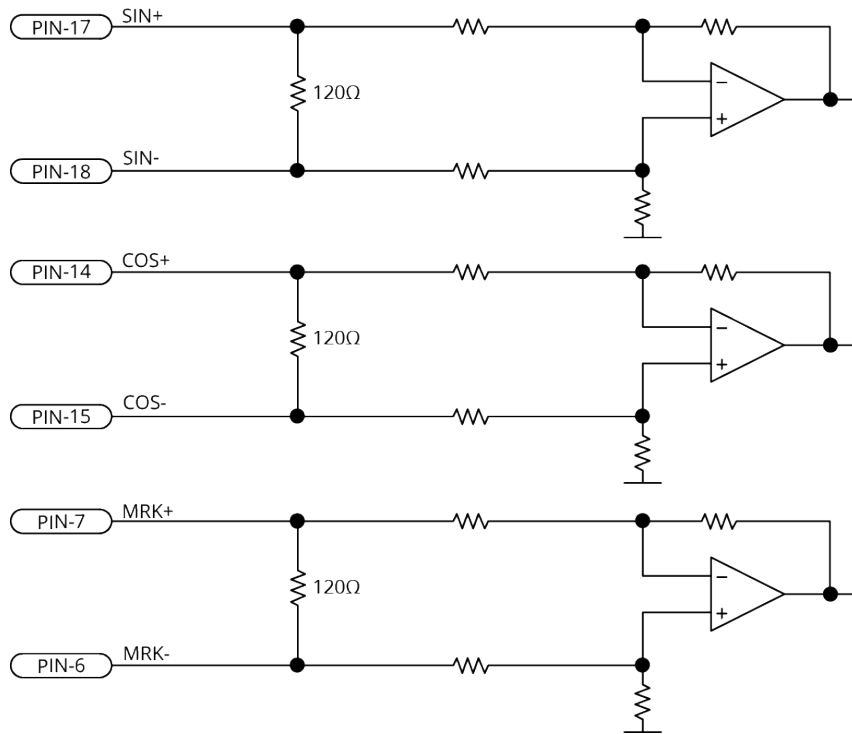

Figure 2-18: Sine Wave Encoder Schematic (Feedback Connector)

2.3.1.4. Encoder Phasing

Incorrect encoder polarity will cause the system to fault when enabled or when a move command is issued. [Figure 2-19](#) illustrates the proper encoder phasing for clockwise motor rotation (or positive forcer movement for linear motors). To verify, move the motor by hand in the CW (positive) direction while observing the position of the encoder in the diagnostics display (see [Figure 2-20](#)).

For dual loop systems, the velocity feedback encoder is displayed in the diagnostic display ([Figure 2-20](#)).

Figure 2-19: Encoder Phasing Reference Diagram (Standard)

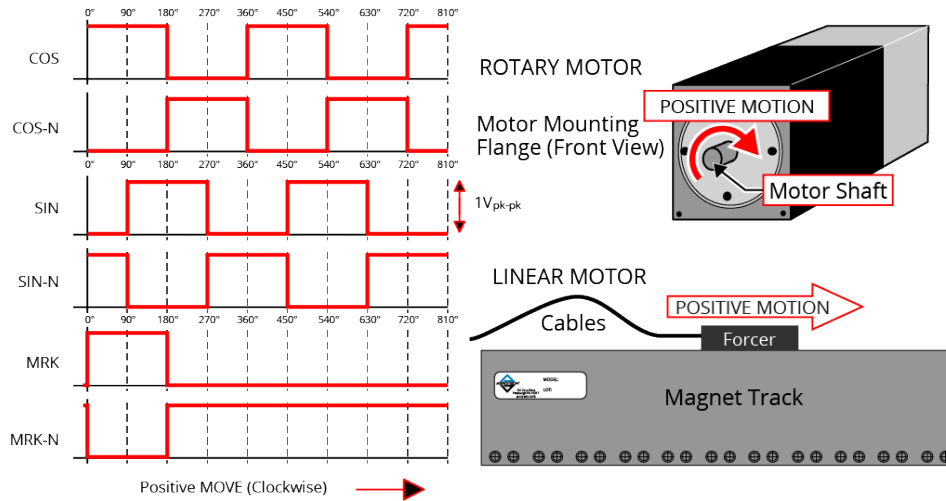

IMPORTANT: Encoder manufacturers may refer to the encoder signals as A, B, and Z. The proper phase relationship between signals is shown in [Figure 2-19](#).

Figure 2-20: Position Feedback in the Diagnostic Display

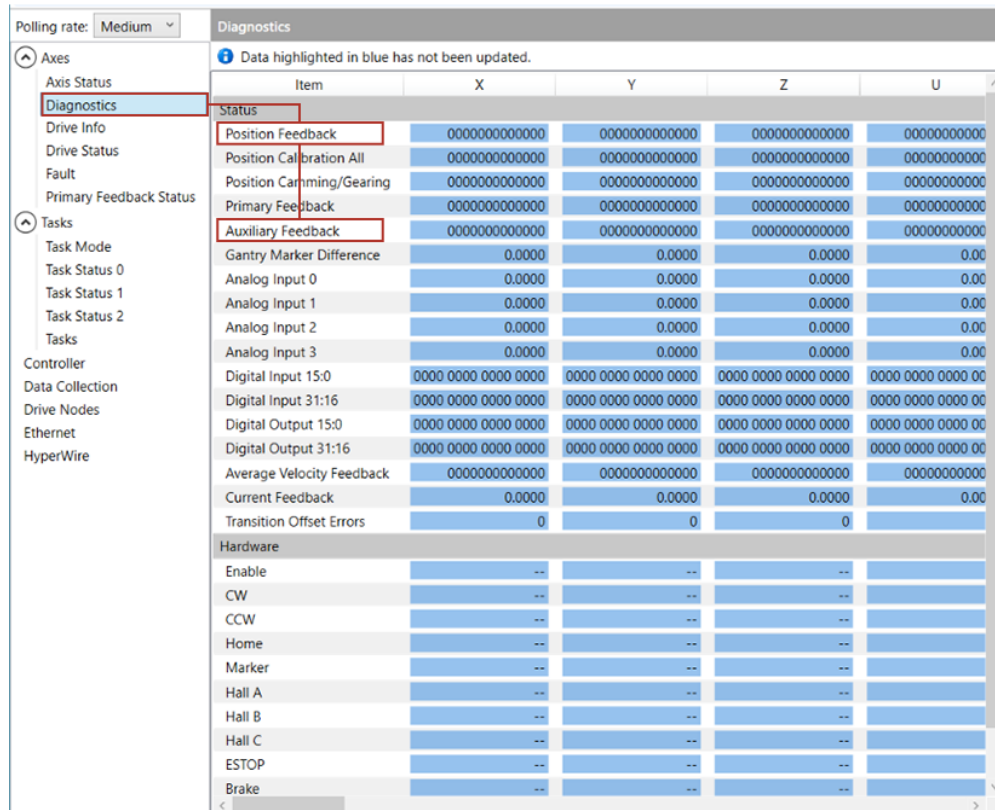

2.3.2. Hall-Effect Inputs

The Hall-effect switch inputs are recommended for AC brushless motor commutation but not absolutely required. The Hall-effect inputs accept 5 VDC level signals. Hall states (0,0,0) or (1,1,1) are invalid and will generate a "Hall Fault" axis fault.

Refer to [Section 2.2.1.1](#) for Hall-effect device phasing.

Table 2-19: Hall-Effect Feedback Pins on the Feedback Connector

Pin #	Description	In/Out/Bit
3	+5V Power ⁽¹⁾	Output
5	Hall-Effect Sensor B (brushless motors only)	Input
10	Hall-Effect Sensor A (brushless motors only)	Input
11	Hall-Effect Sensor C (brushless motors only)	Input
16	+5V Power ⁽¹⁾	Output
20	Signal Common	Output
21	Signal Common	Output

(1) The maximum combined current output is 500 mA.

Figure 2-21: Hall-Effect Inputs Schematic (Feedback Connector)

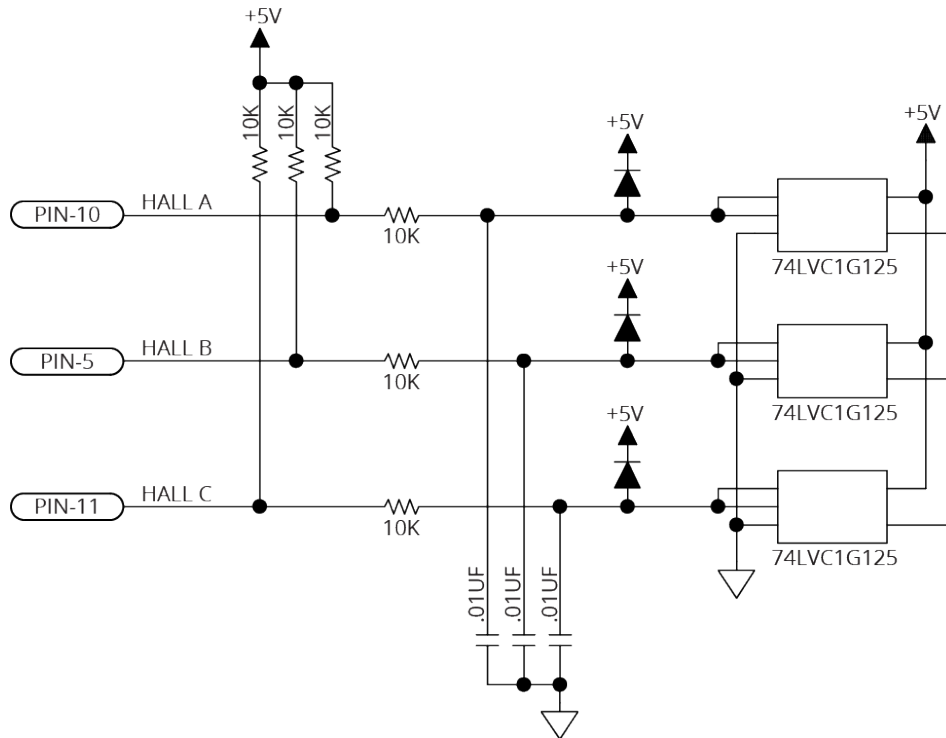

2.3.3. Thermistor Input

The thermistor input is used to detect a motor over temperature condition by using a positive temperature coefficient sensor. As the temperature of the sensor increases, so does the resistance. Under normal operating conditions, the resistance of the thermistor is low which will result in a low input signal. As the increasing temperature causes the resistance of the thermistor to increase, the sensor will trigger an over temperature fault.

The thermistor is connected between Pin 2 and Signal Common. The nominal trip value of the sensor is 1.385 k Ω . The circuit includes a 12 k Ω internal pull-up resistor which corresponds to a trip voltage of +0.52 V.

Table 2-20: Thermistor Input Pin on the Feedback Connector

Pin #	Description	In/Out/BI
2	Motor Over Temperature Thermistor	Input

Figure 2-22: Thermistor Input Schematic (Feedback Connector)

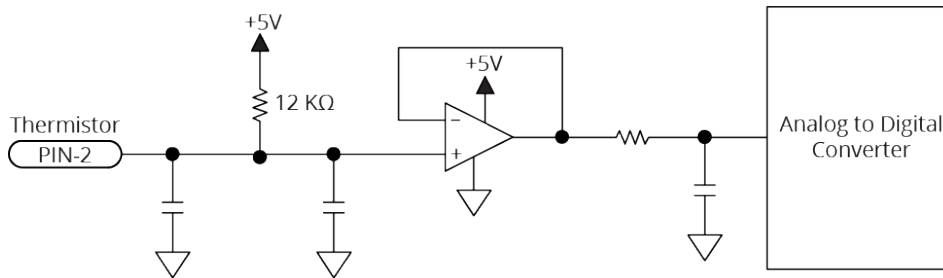

2.3.4. Encoder Fault Input

The encoder fault input is for use with encoders that have a fault output. This is provided by some manufacturers and indicates a loss of encoder function. The active state of this input is parameter configurable and the controller should be configured to disable the axis when the fault level is active.

The nominal trip voltage of the encoder fault input is +2.5 V.

Table 2-21: Encoder Fault Input Pin on the Feedback Connector

Pin #	Description	In/Out/BI
23	Encoder Fault Input	Input

Figure 2-23: Encoder Fault Input Schematic (Feedback Connector)

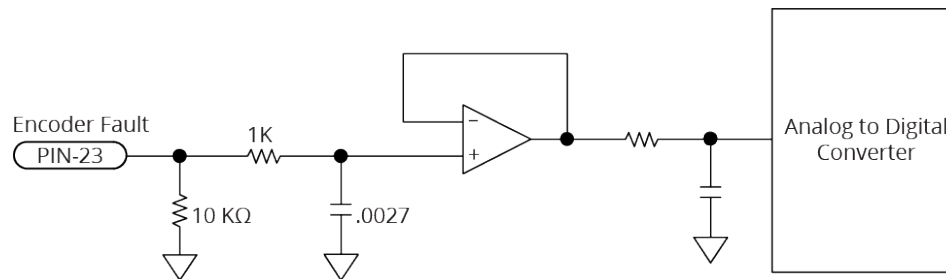

2.3.5. End of Travel and Home Limit Inputs

End of Travel (EOT) limits are required to define the end of the physical travel on linear axes. Positive or clockwise motion is stopped by the clockwise (CW) end of travel limit input. Negative or counterclockwise motion is stopped by the counterclockwise (CCW) end of travel limit input. The Home Limit switch can be parameter configured for use during the home cycle, however, the CW or CCW EOT limit is typically used instead. All of the end-of-travel limit inputs accept 0-24 VDC level signals. Limit directions are relative to the encoder polarity in the diagnostics display (refer to [Figure 2-26](#)).

Table 2-22: End of Travel and Home Limit Pins on the Feedback Connector

Pin #	Description	In/Out/Bi
12	Clockwise End of Travel Limit	Input
16	+5V Power ⁽¹⁾	Output
20	Signal Common	Output
21	Signal Common	Output
22	Home Switch Input	Input
24	Counterclockwise End of Travel Limit	Input

(1) The maximum combined current output is 500 mA.

The active state (High/Low) of the EOT limits is software selectable (by the EndOfTravelLimitSetup axis parameter). [Figure 2-24](#) shows the possible wiring configurations for normally-open and normally-closed switches and the parameter setting to use for each configuration.



IMPORTANT: Use NPN-type normally-closed limit switches (Active High) to provide fail-safe behavior in the event of an open circuit.

Figure 2-24: End of Travel and Home Limit Input Connections

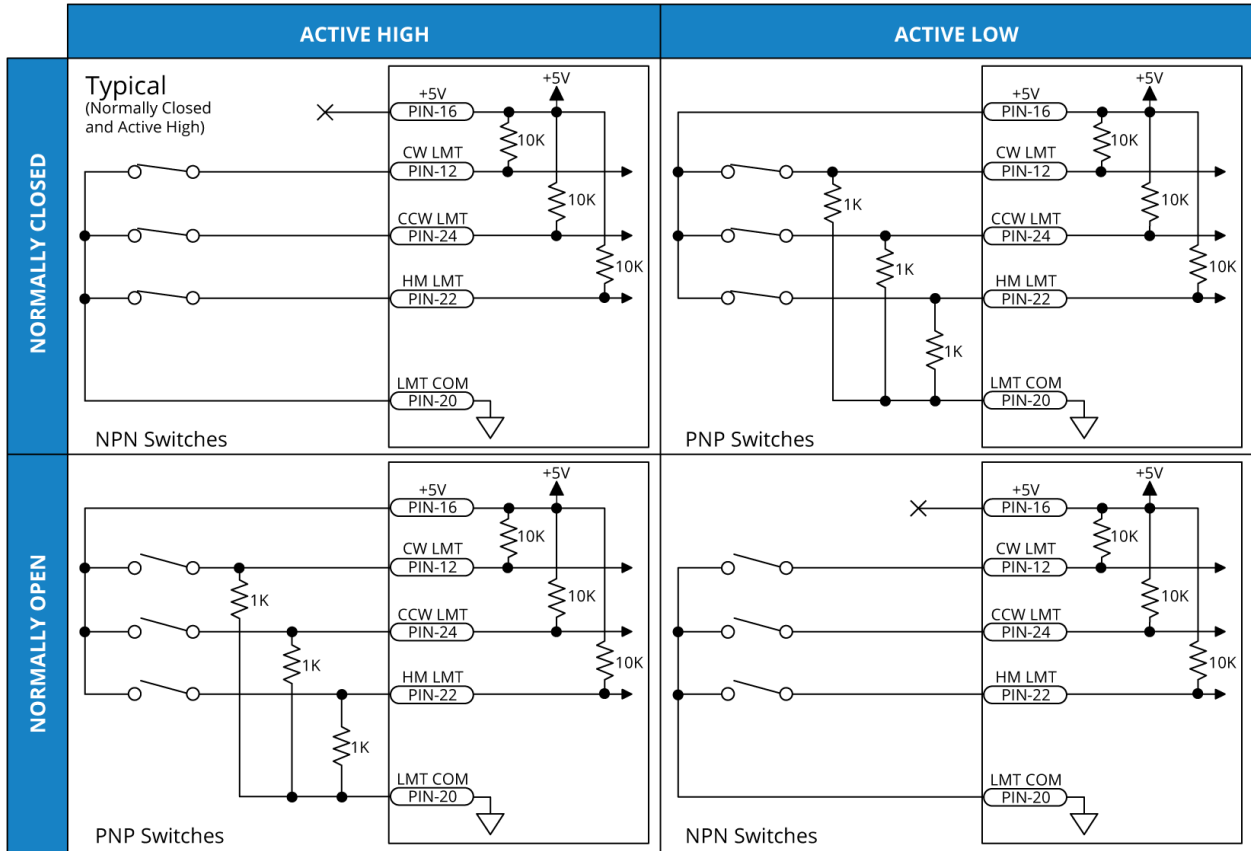
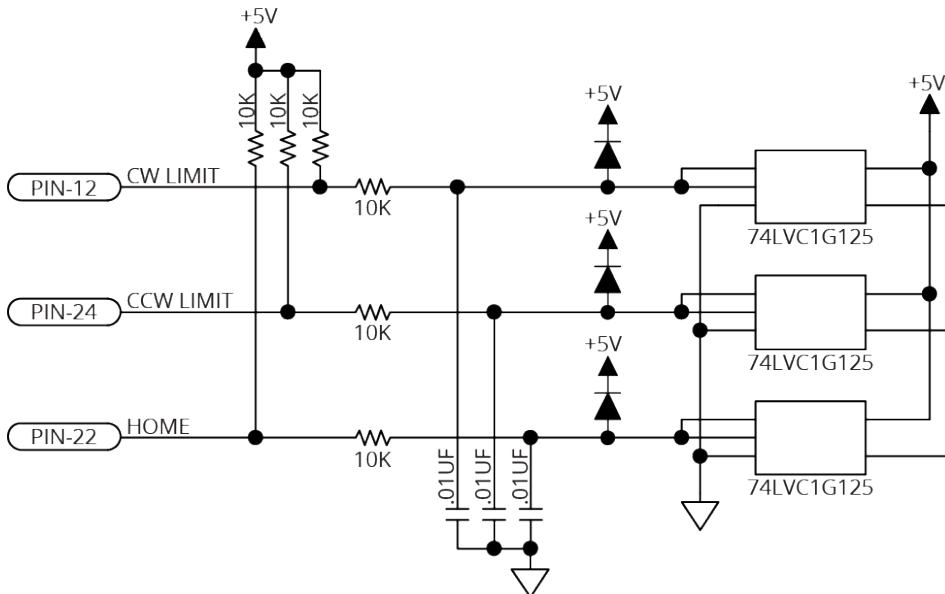

Figure 2-25: End of Travel and Home Limit Input Schematic (Feedback Connector)



2.3.5.1. End of Travel and Home Limit Phasing

If the EOT limits are reversed, you will be able to move further into a limit but be unable to move out. To correct this, swap the connections to the CW and CCW inputs at the Feedback connector or swap the CW and CCW limit functionality in the software using the EndOfTravelLimitSetup parameter. View the logic level of the EOT limit inputs in the Diagnostics display (shown in [Figure 2-26](#)).

Figure 2-26: End of Travel and Home Limit Input Diagnostic Display

Poling rate: Medium

Diagnostics

Data highlighted in blue has not been updated.

Item	X	Y	Z	U
Status				
Position Feedback	000000000000	000000000000	000000000000	000000000000
Position Calibration All	000000000000	000000000000	000000000000	000000000000
Position Camming/Gearing	000000000000	000000000000	000000000000	000000000000
Primary Feedback	000000000000	000000000000	000000000000	000000000000
Auxiliary Feedback	000000000000	000000000000	000000000000	000000000000
Gantry Marker Difference	0.0000	0.0000	0.0000	0.00
Analog Input 0	0.0000	0.0000	0.0000	0.00
Analog Input 1	0.0000	0.0000	0.0000	0.00
Analog Input 2	0.0000	0.0000	0.0000	0.00
Analog Input 3	0.0000	0.0000	0.0000	0.00
Digital Input 15:0	0000 0000 0000 0000	0000 0000 0000 0000	0000 0000 0000 0000	0000 0000 0000 00
Digital Input 31:16	0000 0000 0000 0000	0000 0000 0000 0000	0000 0000 0000 0000	0000 0000 0000 00
Digital Output 15:0	0000 0000 0000 0000	0000 0000 0000 0000	0000 0000 0000 0000	0000 0000 0000 00
Digital Output 31:16	0000 0000 0000 0000	0000 0000 0000 0000	0000 0000 0000 0000	0000 0000 0000 00
Average Velocity Feedback	000000000000	000000000000	000000000000	000000000000
Current Feedback	0.0000	0.0000	0.0000	0.00
Transition Offset Errors	0	0	0	
Hardware				
Enable	--	--	--	--
CW	--	--	--	--
CCW	--	--	--	--
Home	--	--	--	--
Marker	--	--	--	--
Hall A	--	--	--	--
Hall B	--	--	--	--
Hall C	--	--	--	--
ESTOP	--	--	--	--
Brake	--	--	--	--

2.3.6. Brake Outputs

The drive has a dedicated brake control circuit. Configure the brake with the BrakeSetup parameter for automatic control (typical). You can also use software commands to directly control the brake output.

Refer to [Section 2.6](#) for more information on powering the brake circuit.

Table 2-23: Brake Output Pins on the Feedback Connector

Pin #	Description	In/Out/Bit
13	Brake Output -	Output
25	Brake Output +	Output

Table 2-24: Brake Control Specifications

Specification	Value
Maximum Voltage	24 VDC
Maximum Current	1 A

A varistor must be connected across the brake to minimize voltage transients.

Figure 2-27: Brake Connected to the 25-Pin Feedback Connector (Typical)

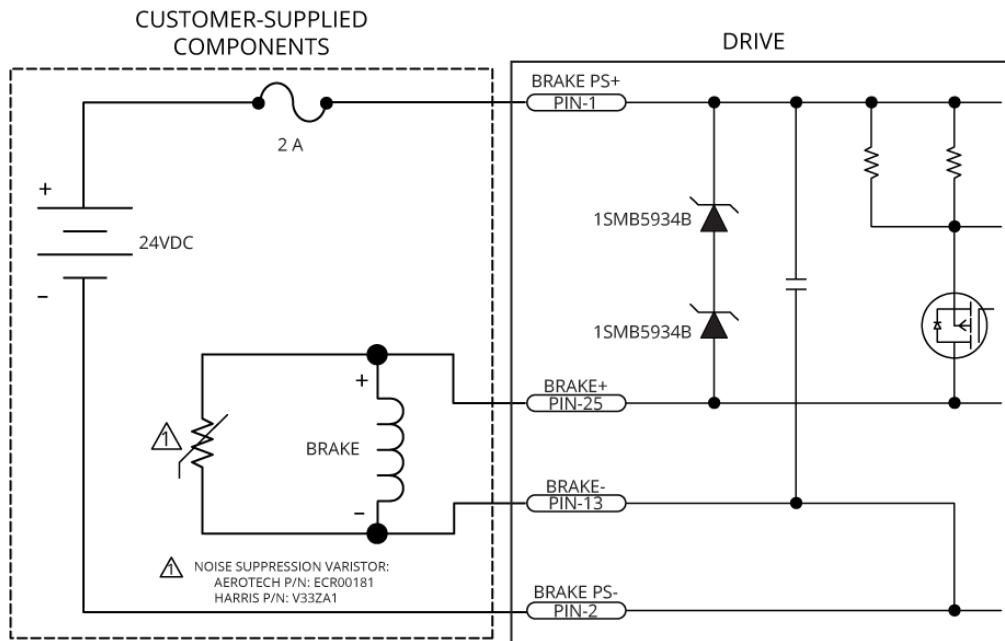

2.4. Safe Torque Off Input (STO)

The STO circuit is comprised of two identical channels, each of which must be energized in order for the drive to produce motion. Each STO input is opto-isolated and accepts 24 V levels directly without the need for external current limiting resistors.



IMPORTANT: The drive might be equipped with an STO bypass circuit board. The bypass circuit board defeats the STO safety circuit and allows the system to run at all times. To use the STO safety functionality, remove the circuit board and make connections as outlined in this section. Refer to [Installation Overview](#) on [Page 15](#) for the location of the STO bypass plug.



IMPORTANT: The application circuit and its suitability for the desired safety level is the sole responsibility of the user of the drive.



WARNING: STO wires must be insulated to prevent short circuits between connector pins. The primary concern is a short circuit between STO 1 IN and STO 2 IN wire strands.

Table 2-25: STO Connector Pinout

Pin #	Signal	Description	In/Out/Bi	Connector
1	Power Supply +	Use only to defeat STO by connecting to STO 1 IN and STO 2 IN. Not for customer use.	Output	
2	STO 1 IN	STO Channel 1 Positive Input	Input	
3	RETURN	STO Negative Input	Input	
4	STO 2 IN	STO Channel 2 Positive Input	Input	
5	Power Supply -	Use only to defeat STO by connecting to RETURN. Not for customer use.	Output	

Table 2-26: STO Mating Connector Ratings

Specification		Description
Type		5-Pin Terminal Block
Part Numbers		Aerotech: ECK02393 Phoenix: 1827622
Conductor Cross Section	One conductor, stranded with ferrule and plastic sleeve	18...22 AWG (0.25...0.75 mm ²)
	Two conductors (same cross-section), stranded, twin ferrule with plastic sleeve	20 AWG (0.5 mm ²)
Tightening Torque		0.22...0.25 N·m
Conductor Insulation Strip Length		7 mm (0.25 in)
(1) Refer to the manufacturer website for additional information.		

Table 2-27: STO Electrical Specifications

Status	Value
STO off (motion allowed)	18-24 V, 7 ma
STO on (safe state entered, no motion)	0-6 V
Recommended Wire Gauge	22-26 AWG (0.5 - 0.14 mm ²)
STO System Power Supply	PELV
STO Wire Length (maximum)	50 m

Figure 2-28 shows one safety device connected to multiple drives in parallel.



WARNING: The drive does not check for short circuits on the external STO wiring. If this is not done by the external safety device, short circuits on the wiring must be excluded. Refer to EN ISO 13849-2. For Category 4 systems, the exclusion of short circuits is mandatory.

Figure 2-28: Typical STO Configuration

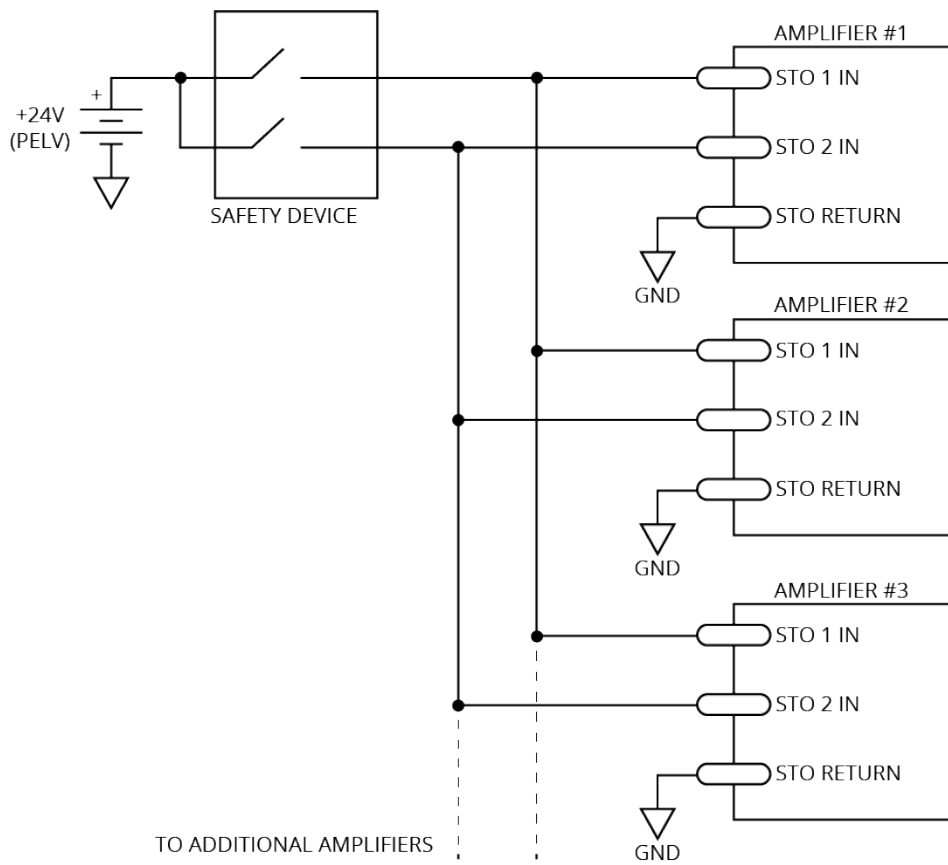

2.4.1. STO Standards

Table 2-28 describes and specifies the safety requirements at the system level for the Safe Torque Off (STO) feature of the drive. This assumes that diagnostic testing is performed according to Section 2.4.4. and Table 2-29.

Table 2-28: STO Standards

Standard	Maximum Achievable Safety
EN/IEC 61800-5- 2:2016	SIL 3
EN/IEC 61508-1:2010	SIL 3
EN/IEC 61508-2:2010	SIL 3
EN ISO 13849-1:2015	Category 4, PL e
EN/IEC 62061:2005 with Amendments	SIL 3

Table 2-29: STO Standards Data

Standard	Value
EN ISO 13849-1:2015	MTTF _D > 1000 years, DC _{AVG} 99% Maximum PL e, Category 4
EN ISO 13849-1:2015 EN/IEC 61508	Lifetime = 20 years No proof test required Interval for manual STO test: <ul style="list-style-type: none"> Once per year for SIL2/PL d/category 3 Once per three months for SIL3/PL e/category 3 Once per day for SIL3/PL e/category 4
EN/IEC 61508	SIL3 PFH < 3 FIT SFF > 99%

2.4.2. STO Functional Description

The motor can only be activated when voltage is applied to both STO 1 and STO 2 inputs. The STO state will be entered if power is removed from either the STO 1 or the STO 2 inputs. When the STO state is entered, the motor cannot generate torque or force and is therefore considered safe. Both STO channels must be driven at the same time. If they are not driven at the same time, a diagnostic test failure will occur (refer to [STO Diagnostics](#)).

The STO function is implemented with two redundant channels in order to meet stated performance and SIL levels. STO 1 disconnects the high side power amplifier transistors and STO 2 disconnects the low side power amplifier transistors. Disconnecting either set of transistors effectively prevents the drive from being able to produce motion.

The drive software monitors each STO channel and will generate an Emergency Stop software fault when either channel signals the stop state. Each STO channel contains a fixed delay which allows the drive to perform a controlled stop before the power amplifier transistors are turned off.

A typical configuration requiring a controlled stop has the Emergency Stop Fault mask bit set in the FaultMask, FaultMaskDecel, and FaultMaskDisable parameters. This stops the axis using the rate specified by the AbortDecelRate parameter. The software will disable the axis as soon as the deceleration ramp is complete. This is typically configured to occur before the STO channel turns off the power amplifier transistors.

The software-controlled stop functionality must be excluded when considering overall system safety. This is because the software is not safety rated and cannot be included as part of the safety function.

The software-controlled stop function can ignore short diagnostic pulses on the STO 1+ and STO 2+ inputs. The parameter "STOPulseFilter" specifies the maximum pulse width that the software will ignore. The filter parameter does not affect the operation of STO hardware channels.

To resume normal operation, apply power to both STO 1 and STO 2 inputs and use the *Acknowledge All* button or the AcknowledgeAll() or FaultAcknowledge() function to clear the Emergency Stop software fault. The recommended use of the Emergency Stop Fault fault mask bits prevent the system from automatically restarting.

You can achieve longer delay times through the use of an external delay timer, such as the Omron G9SA-321 Safety Relay Unit. Place this device between the system ESTOP wiring and the drive's STO inputs. Connect the ESTOP signal directly to a digital input, in addition to the external timer, to allow the drive to begin a software-controlled stop as soon as the ESTOP signal becomes active. Use the EmergencyStopFaultInput parameter to configure a digital input as an ESTOP input.

The STO feature can only be used with AC or stepper motor types. It is not certified to prevent hazardous motion when using DC brush motor types.

Non-standard STO delay times are provided by special factory order. In this case, the non-standard STO delay time is indicated by a label placed on the slice amplifier's main connector (STO DELAY = xx sec).

Table 2-30: STO Signal Delay

	Value
STO Time Delay	450-550 msec

Table 2-31: Motor Function Relative to STO Input State

STO 1	STO 2	Motor Function
Unpowered	Unpowered	No force/torque
Unpowered ⁽¹⁾	Powered ⁽¹⁾	No force/torque
Powered ⁽¹⁾	Unpowered ⁽¹⁾	No force/torque
Powered	Powered	Normal Operation

1. This is considered a Fault Condition since STO 1 and STO 2 do not match. Refer to [Section 2.4.4](#).

2.4.3. STO Startup Validation Testing

Verify the state of the STO 1 and STO 2 channels by manually activating the external STO hardware. Each STO channel must be tested separately in order to detect potential short circuits between the channels. The current state of the STO 1 and STO 2 inputs is shown in the Status Utility. A “–” indicates that the STO input is powered by a high voltage level (24 V). An “ON” indicates that the voltage source has been removed from the input (open circuit or 0 V), and that the STO channel is in the safe state.



DANGER: The STO circuit does not remove lethal voltage from the motor terminals. AC mains power must be removed before servicing.

2.4.4. STO Diagnostics

Activation of STO means removing power from the drive STO inputs. This is typically done by pressing the emergency stop switch. The drive initiates a diagnostic check every time the STO is activated after the Diagnostic Test Delay Time has elapsed. The diagnostic check verifies that each channel has entered the safe state. The drive is held in the safe state if it determines that one of the channels has not properly entered the safe state. An open circuit or short to 24 V in either STO channel will result in this condition (refer to [Section 2.4.3.](#)). The Status Utility screen can be used to verify the levels of the STO input signals while troubleshooting. The safe state is cleared when both STO channels are cycled with matching signal levels such that the diagnostic test completes successfully.

The drive is held in the safe state if it determines that one of the channels has not properly entered the safe state. In this case, the `stoCrossCheckFault` bit will be set and can be viewed in the **STO Status** status item. A **Position Error Fault** or **Emergency Stop Fault** will occur if motion is attempted while in this state. The drive will remain in the safe state until STO is reactivated with both channels in a safe state such that the diagnostics test completes successfully.

An open circuit or short to 24 V in either STO channel or a timing difference between the channels will result in a diagnostic test failure (refer to [STO Startup Validation Testing](#)). The Status Utility screen or **STO Status** status item can be used to verify the levels of the STO input signals while troubleshooting.

In order to pass internal testing, the STO circuit must be activated (power removed from both inputs) according to the interval specified in [Table 2-29](#).

Table 2-32: STO Timing

Time	Description	Value
T1	STO Delay Time (STO input active to motor power off)	450-550 msec
T2	STO deactivated to motor power on (the software is typically configured so that the motor does not automatically re-energize).	< 1 msec
T3	Diagnostic Test Delay Time	550-610 msec

Figure 2-29: STO Timing

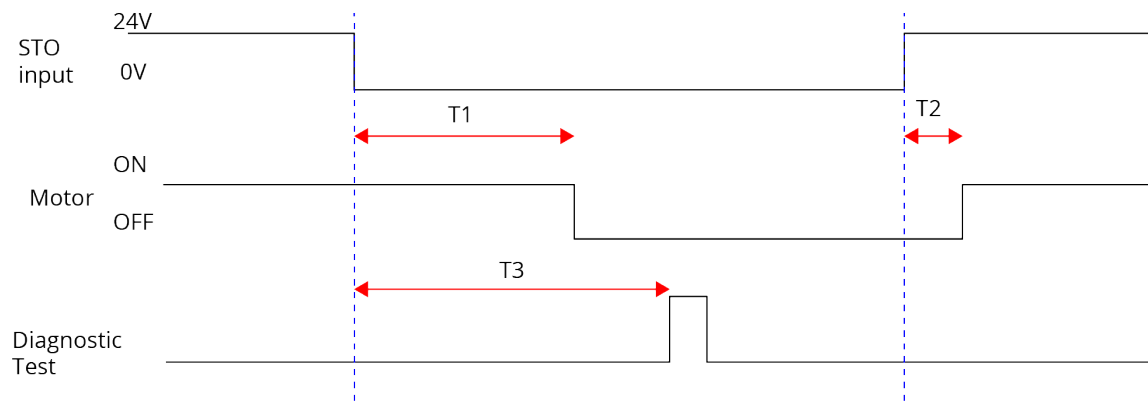

The software is typically configured to execute a controlled stop when the STO state is first detected. If power is reapplied to the STO inputs before the STO Delay Time, an STO hardware shutdown will not occur but a software stop may, depending on the width of the STO pulse. The controller will ignore STO active pulses shorter in length than the `STOPulseFilter` parameter setting.

2.5. Auxiliary I/O Connector

The Auxiliary I/O connector has 1 analog input, 6 digital inputs, 1 analog output, 4 digital outputs, a secondary line driver encoder input, and a secondary absolute encoder interface.

Table 2-33: Auxiliary I/O Connector Pinout

Pin#	Description	In/Out/Bi	Connector
1	Auxiliary Sine +	Bidirectional	
	Absolute Encoder Data +	Bidirectional	
2	Auxiliary Sine -	Bidirectional	
	Absolute Encoder Data -	Bidirectional	
3	High-Speed Input 20 + / PSO External Sync. +	Input	
4	High-Speed Input 20 - / PSO External Sync. -	Input	
5	High-Speed Input 21 +	Input	
6	High-Speed Input 21 -	Input	
7	Digital Output 0	Output	
8	Digital Output 1	Output	
9	Digital Output 2	Output	
10	Auxiliary Cosine +	Bidirectional	
	Absolute Encoder Clock +	Output	
11	Auxiliary Cosine-	Bidirectional	
	Absolute Encoder Clock -	Output	
12	+5 V (500 mA max)	Output	
13	Analog Input 0+ (Differential)	Input	
14	Analog Input 0- (Differential)	Input	
15	Digital Output Common	Output	
16	Digital Output 3	Output	
17	Digital Input 0 / CCW EOT Input ⁽¹⁾	Input	
18	Digital Input 1 / CW EOT Input ⁽¹⁾	Input	
19	Auxiliary Marker - / PSO ⁽²⁾ Differential Output - / PSO TTL Output	Bidirectional	
20	Auxiliary Marker + / PSO ⁽²⁾ Differential Output +	Bidirectional	
21	Common	Output	
22	Analog Output 0	Output	
23	Analog Common	Output	
24	Digital Input Common	Output	
25	Digital Input 2 / Home Input ⁽¹⁾	Input	
26	Digital Input 3	Input	

(1) Software configured option
 (2) For PSO, refer to [Section 2.5.2](#).

Table 2-34: Auxiliary I/O Mating Connector Ratings

Specification	26-Pin Solder Cup	Backshell
Aerotech Part Number	ECK01259	ECK01022
Manufacturer Part Number ⁽¹⁾	Kycon K86-AA-26P	Amphenol 17E-1725-2
Maximum Wire Size	22 AWG (0.25 mm ²)	N/A

(1) Refer to the manufacturer website for additional information.

2.5.1. Auxiliary Encoder Interface

The Auxiliary Encoder connector gives you a second encoder channel. This channel is typically used for dual loop applications.

Use the AuxiliaryFeedbackType parameter to configure the iXL5e/XL5e to accept an encoder signal type.

Square Wave encoder signals: [Section 2.5.1.1.](#)

Absolute encoder signals: [Section 2.5.1.2.](#)

Sine Wave encoder signals (with the -MX3 option): [Section 2.5.1.3.](#)

You can configure the Auxiliary Encoder interface as an output that will transmit encoder signals for external use. Use the DriveEncoderOutputConfigureInput() function to configure the Sine \pm and Cosine \pm connector pins as RS-422 outputs. You can only echo incremental square wave primary encoder inputs or, with the -MX2 or -MX3 option, incremental sine wave primary encoder inputs. You cannot use the absolute encoder interface when you echo incremental signals.

Table 2-35: Auxiliary Encoder Pins on the Auxiliary I/O Connector

Pin#	Description	In/Out/Bi
1	Auxiliary Sine +	Bidirectional
	Absolute Encoder Data +	Bidirectional
2	Auxiliary Sine -	Bidirectional
	Absolute Encoder Data -	Bidirectional
10	Auxiliary Cosine +	Bidirectional
	Absolute Encoder Clock +	Output
11	Auxiliary Cosine-	Bidirectional
	Absolute Encoder Clock -	Output
12	+5 V (500 mA max)	Output
19	Auxiliary Marker - / PSO ⁽²⁾ Differential Output - / PSO TTL Output	Bidirectional
20	Auxiliary Marker + / PSO ⁽²⁾ Differential Output +	Bidirectional
21	Common	Output

(2) For PSO, refer to [Section 2.5.2.](#)

2.5.1.1. Square Wave Encoder (Auxiliary)

The drive accepts RS-422 square wave encoder signals. The drive will generate a feedback fault if it detects an invalid signal state caused by an open or shorted signal connection. Use twisted-pair wiring for the highest performance and noise immunity.

Table 2-36: Square Wave Encoder Specifications

Specification	Value
Encoder Frequency	10 MHz maximum (25 ns minimum edge separation)
x4 Quadrature Decoding	40 million counts/sec

Figure 2-30: Square Wave Encoder Interface (Aux I/O Connector)

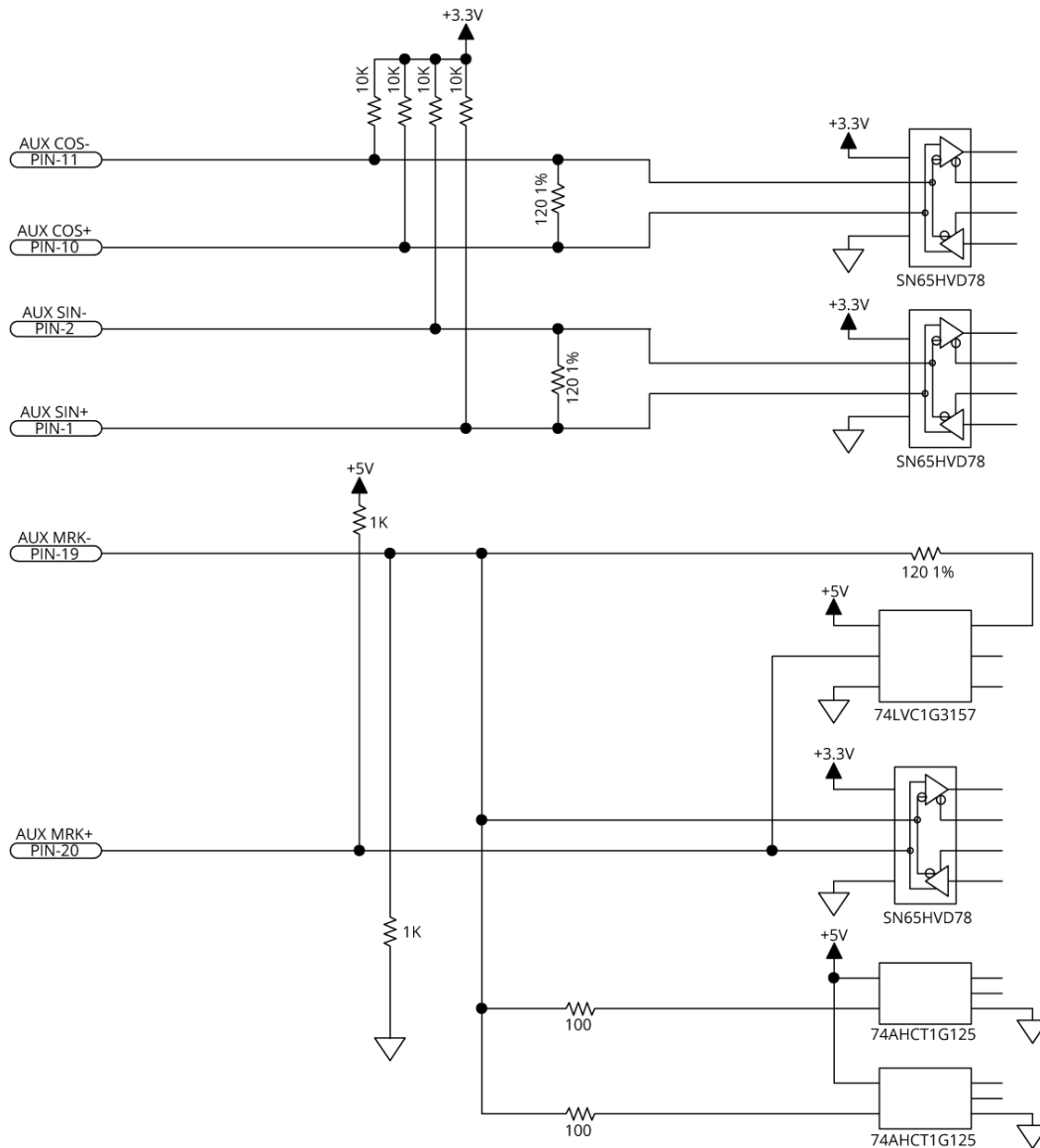

2.5.1.2. Absolute Encoder (Auxiliary)

The drive retrieves absolute position data along with encoder fault information through a serial data stream from the absolute encoder. Use twisted-pair wiring for the highest performance and noise immunity. You cannot use an absolute encoder with incremental signals on the Auxiliary I/O Connector.

Refer to [Figure 2-31](#) for the serial data stream interface.

Refer to the Help file for information on how to set up your EnDat, BiSS, or SSI absolute encoder parameters.

Table 2-37: Absolute Encoder Specifications

Specification	Value
Sampling Frequency	20 kHz
Maximum Reading Speed	Refer to your encoder data sheet.

Figure 2-31: Absolute Encoder Schematic (Auxiliary I/O Connector)

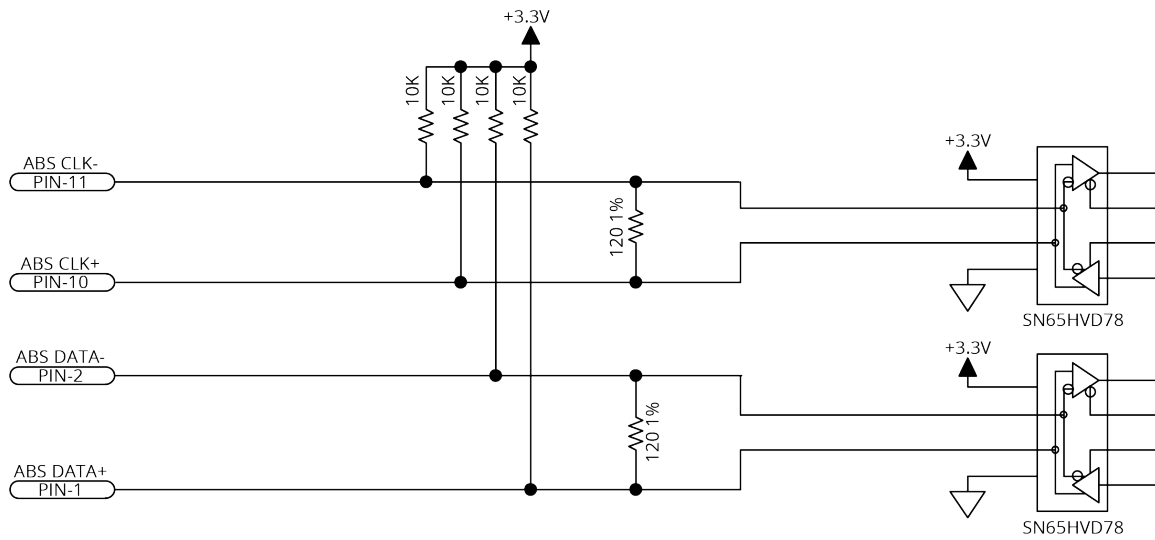

2.5.1.3. Sine Wave Encoder (Auxiliary) [-MX3 Option]

The Sine Wave Encoder option provides higher positioning resolution by subdividing the fundamental output period of the encoder into smaller increments. The amount of subdivision is specified by the AuxiliaryEncoderMultiplicationFactor parameter. Use Encoder Tuning to adjust the value of the gain, offset, and phase balance controller parameters to get the best performance. For more information, refer to the Help file.

You cannot use the sine wave encoder on the auxiliary connector with the -MX3 multiplier option as an input to the PSO. The -MX3 option does not generate emulated quadrature signals from the auxiliary connector.

For the highest performance, use twisted pair double-shielded cable with the inner shield connected to signal common and the outer shield connected to frame ground. Do not join the inner and outer shields in the cable.

Table 2-38: Sine Wave Encoder Specifications

Specification	Value	
	Primary	Auxiliary
Input Frequency (max)	450 kHz, 2 MHz	450 kHz
Input Amplitude ⁽¹⁾	0.6 to 1.75 Vpk-pk	
Interpolation Factor (max)	-MX2	65,536
	-MX3	65,536
-MX2/-MX3 Primary Encoder Channel Interpolation Latency	800 nsec (analog input to quadrature output)	
Input Common Mode	1.5 to 3.5 VDC	

(1) Measured as SIN(+) - SIN(-) or COS(+) - COS(-)

Figure 2-32: Sine Wave Encoder Phasing Reference Diagram

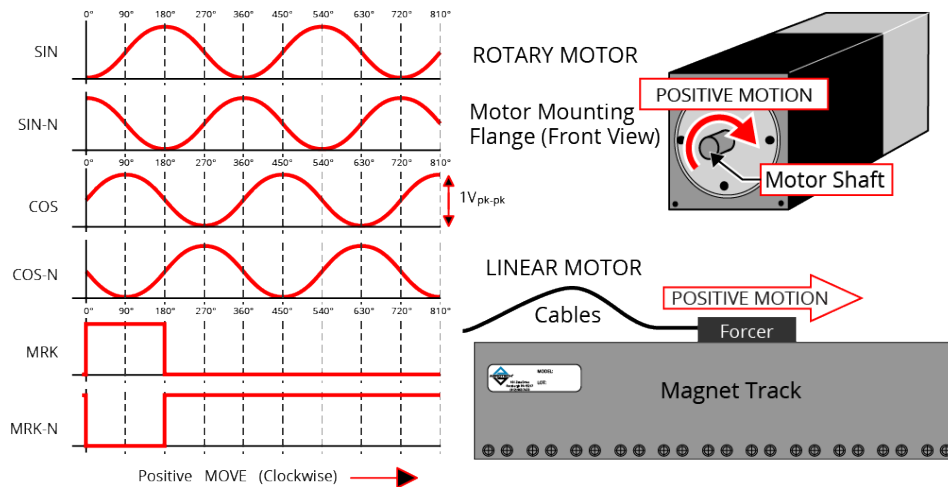
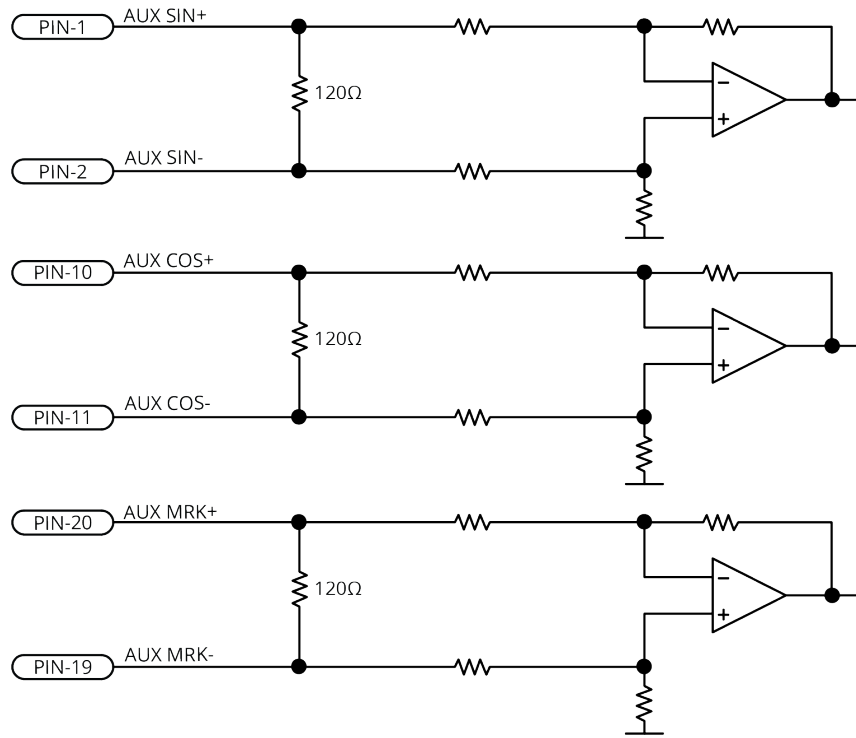

Figure 2-33: Sine Wave Encoder Schematic (Auxiliary I/O Connector)



2.5.2. Position Synchronized Output (PSO)

The PSO signal is available on the dual-function AUX Marker/PSO signal lines. Use the PSO pulse external sync functions to configure the auxiliary marker as an output. Refer to the Help file for more information. Use the `PsoOutputConfigureOutput()` function to transmit the PSO output signal on the Marker \pm pins differentially. Or, use the `PsoOutputConfigureOutput()` function to configure the Marker - pin as a 5V TTL PSO output.

When configured for differential use with pin 19 as PSO Differential Output - and pin 20 as PSO Differential Output +, the PSO output is active low. [Figure 2-34](#) shows how the output pins are biased so that the output is in the OFF state when it is not actively driven. If you want an active high output, you can change the pins so that pin 19 is the PSO Differential Output + and pin 20 is the PSO Differential Output -.

The differential signal format is recommended when using long cable lengths in noisy environments or when high frequency pulse transmission is required. It is best to locate the line receiver close to the receiving electronics. A 5 V TTL signal is used to drive an opto coupler or general purpose TTL input. This signal is active high and is driven to 5 V when a PSO fire event occurs. When the drive is reset or after initial power up, the PSO pins (refer to [Table 2-40](#)), are not actively driven and the fail safe state is defined by pull-up and pull-down resistors as shown in [Figure 2-34](#).

The -EB1 I/O option board has additional PSO signal formats. Refer to [Section 3.5](#) for more information.

Table 2-39: PSO Specifications

Specification		Value
Output	TTL	5 V, 16 mA (max)
Maximum PSO Output (Fire) Frequency	TTL	12.5 MHz
	RS-422	12.5 MHz
Output Latency [Fire event to output change]	TTL	25 ns
	RS-422	25 ns

Table 2-40: PSO Pins on the Auxiliary I/O Connector

Pin#	Description	In/Out/Bi
19	Auxiliary Marker - / PSO Differential Output - / PSO TTL Output	Bidirectional
20	Auxiliary Marker + / PSO Differential Output +	Bidirectional
21	Common	Output

Figure 2-34: PSO Interface

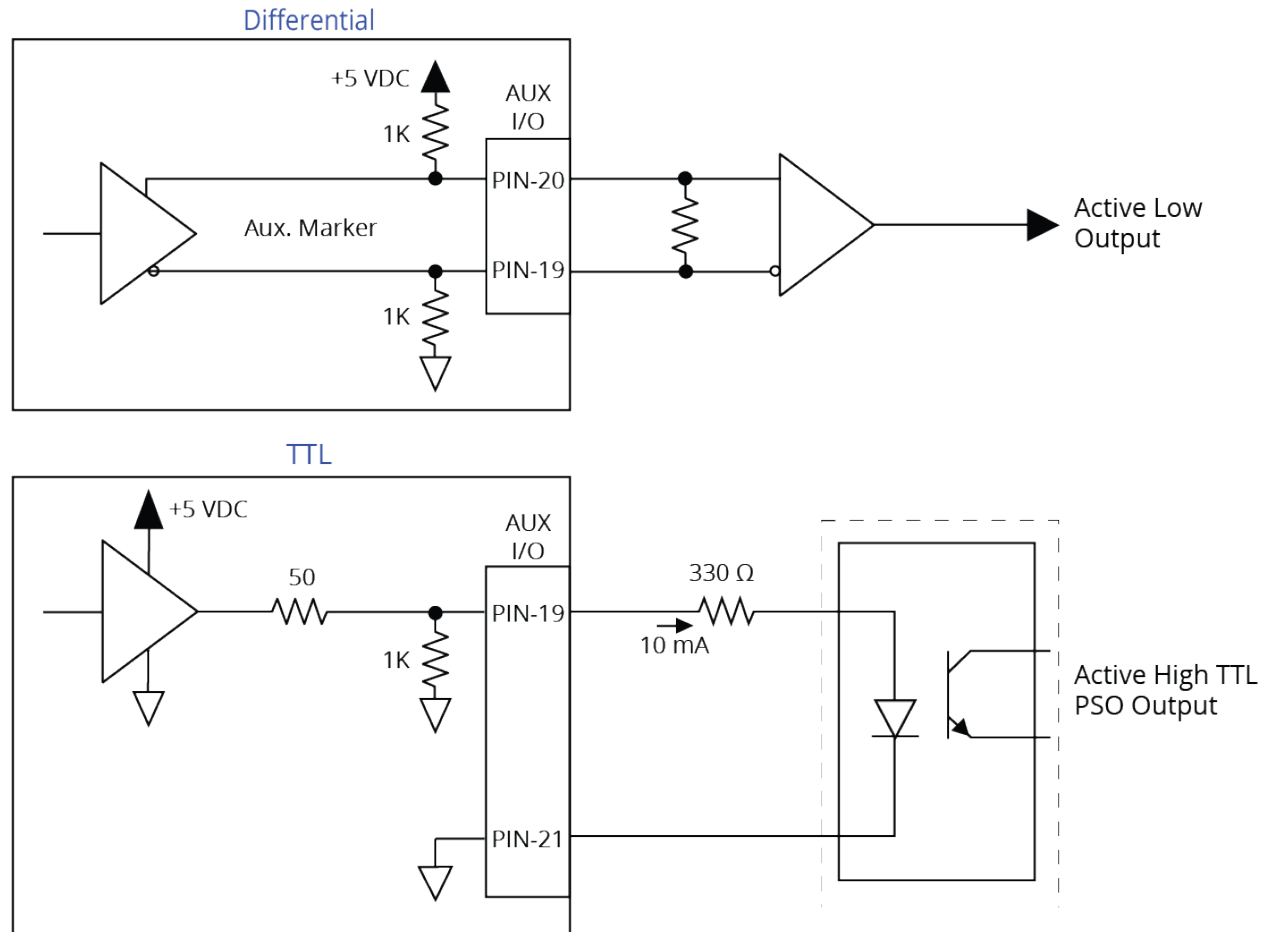

2.5.3. Digital Outputs

Optically-isolated solid-state relays drive the digital outputs. You can connect the digital outputs in current sourcing or current sinking mode but you must connect all four outputs in the same configuration. Refer to [Figure 2-36](#) and [Figure 2-37](#).

You must install suppression diodes on digital outputs that drive relays or other inductive devices. To see an example of a current sourcing output that has diode suppression, refer to [Figure 2-36](#). To see an example of a current sinking output that has diode suppression, refer to [Figure 2-37](#).

The digital outputs are not designed for high-voltage isolation applications and they should only be used with ground-referenced circuits.

The digital outputs have overload protection. They will resume normal operation when the overload is removed.

Table 2-41: Digital Output Specifications

Digital Output Specifications	Value
Maximum Voltage	24 V (26 V Maximum)
Maximum Sink/Source Current	250 mA/output
Output Saturation Voltage	0.9 V at maximum current
Output Resistance	3.7 Ω
Rise / Fall Time	250 μ s (2K pull up to 24V)
Reset State	Output Off (High Impedance State)

Table 2-42: Digital Output Pins on the Auxiliary I/O Connector

Pin#	Description	In/Out/Bi
7	Digital Output 0	Output
8	Digital Output 1	Output
9	Digital Output 2	Output
15	Digital Output Common	Output
16	Digital Output 3	Output

Figure 2-35: Digital Output Schematic (Aux I/O Connector)

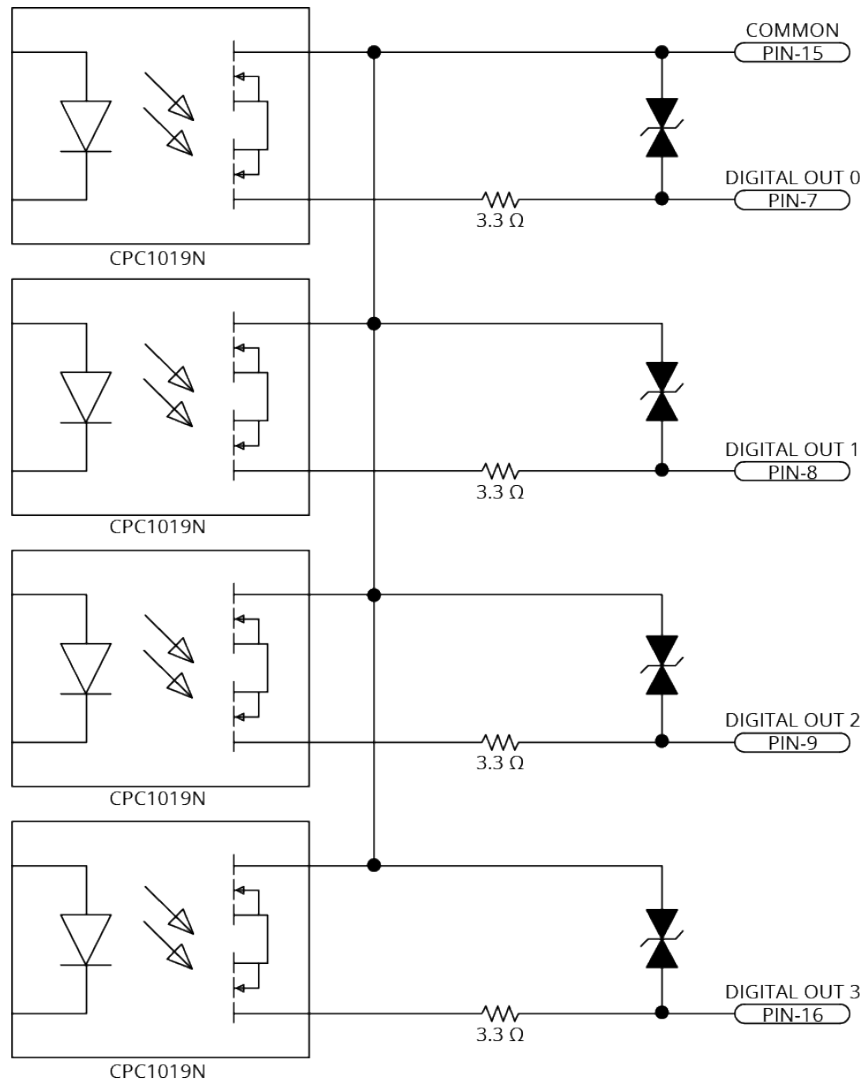
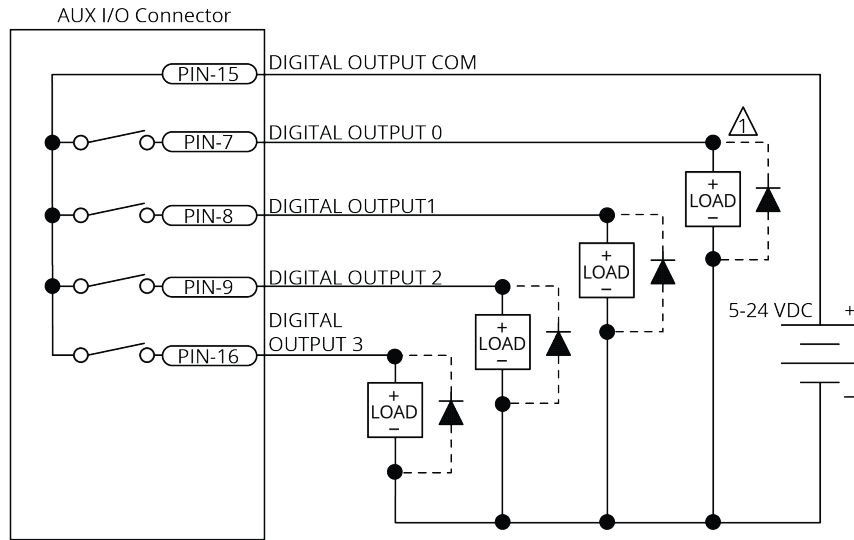
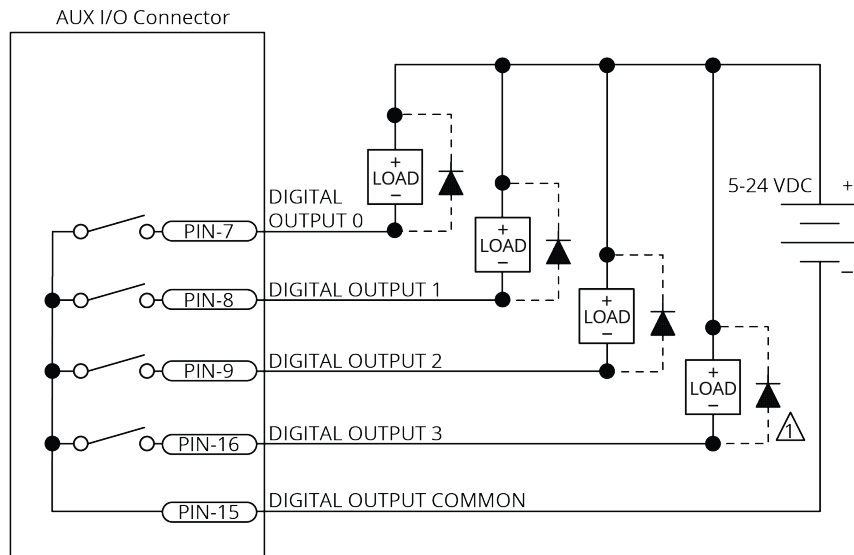

Figure 2-36: Digital Outputs Connected in Current Sourcing Mode



DIODE REQUIRED ON EACH OUTPUT THAT DRIVES AN INDUCTIVE DEVICE (COIL), SUCH AS A RELAY.

Figure 2-37: Digital Outputs Connected in Current Sinking Mode



DIODE REQUIRED ON EACH OUTPUT THAT DRIVES AN INDUCTIVE DEVICE (COIL), SUCH AS A RELAY.

2.5.4. Digital Inputs

You can connect the digital inputs to current sourcing or current sinking devices but you must connect all four inputs in the same configuration. Refer to [Figure 2-39](#) and [Figure 2-40](#). The digital inputs are not designed for high-voltage isolation applications. They should only be used with ground-referenced circuits.

Table 2-43: Digital Input Specifications

Input Voltage	Approximate Input Current	Turn On Time	Turn Off Time
+5 V to +24 V	6 mA	10 μ s	43 μ s

Table 2-44: Digital Input Pins on the Auxiliary I/O Connector

Pin#	Description	In/Out/Bi
17	Digital Input 0 / CCW EOT Input ⁽¹⁾	Input
18	Digital Input 1 / CW EOT Input ⁽¹⁾	Input
24	Digital Input Common	Output
25	Digital Input 2 / Home Input ⁽¹⁾	Input
26	Digital Input 3	Input

(1) Software configured option

Figure 2-38: Digital Inputs Schematic (Aux I/O Connector)

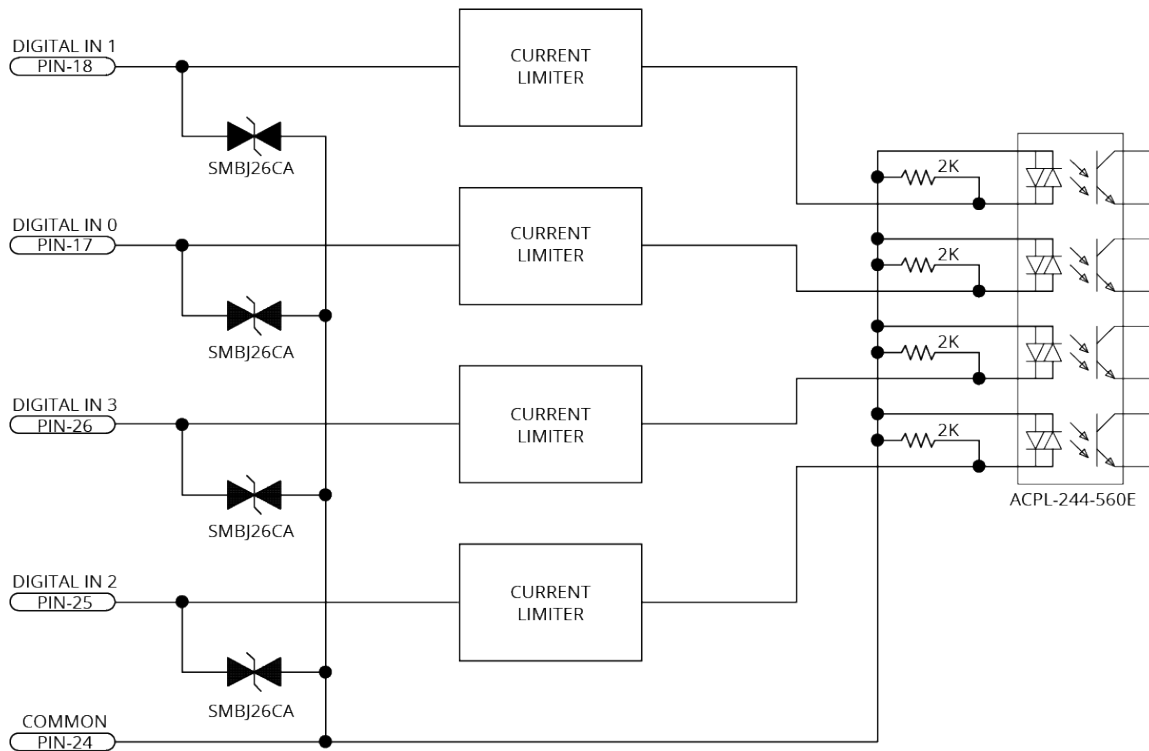

Figure 2-39: Digital Inputs Connected to Current Sourcing Devices

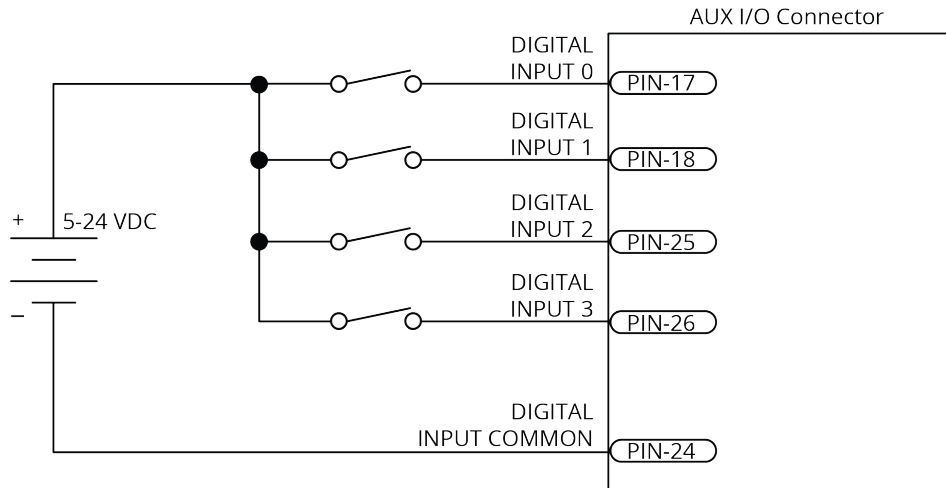
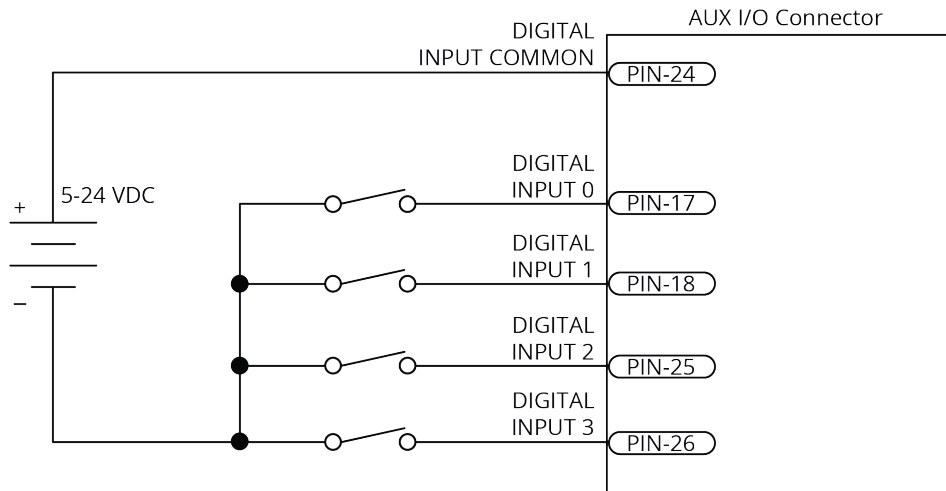

Figure 2-40: Digital Inputs Connected to Current Sinking Devices



2.5.5. High-Speed Inputs

High-speed inputs 20 and 21 can be used as general purpose inputs or as the trigger signal for high speed data collection. Refer to the DriveDataCaptureConfigureTrigger() function topic in the Help file for more information.

You can use the external PSO synchronization functions to synchronize waveform generation with an external synchronization signal. When you activate this feature, the PSO Waveform module will not generate the configured waveform when an output event is received until the rising edge of the synchronization signal occurs.

Table 2-45: High-Speed Input Specifications

Specification	Value
Input Voltage	5V - 24 V input voltages
Input Current	10 mA
Input Device	HCPL-0630
Delay	50 nsec

Table 2-46: High-Speed Input Pins on the Auxiliary I/O Connector

Pin#	Description	In/Out/Bi
3	High-Speed Input 20 + / PSO External Sync. +	Input
4	High-Speed Input 20 - / PSO External Sync. -	Input
5	High-Speed Input 21 +	Input
6	High-Speed Input 21 -	Input

Figure 2-41: High-Speed Inputs

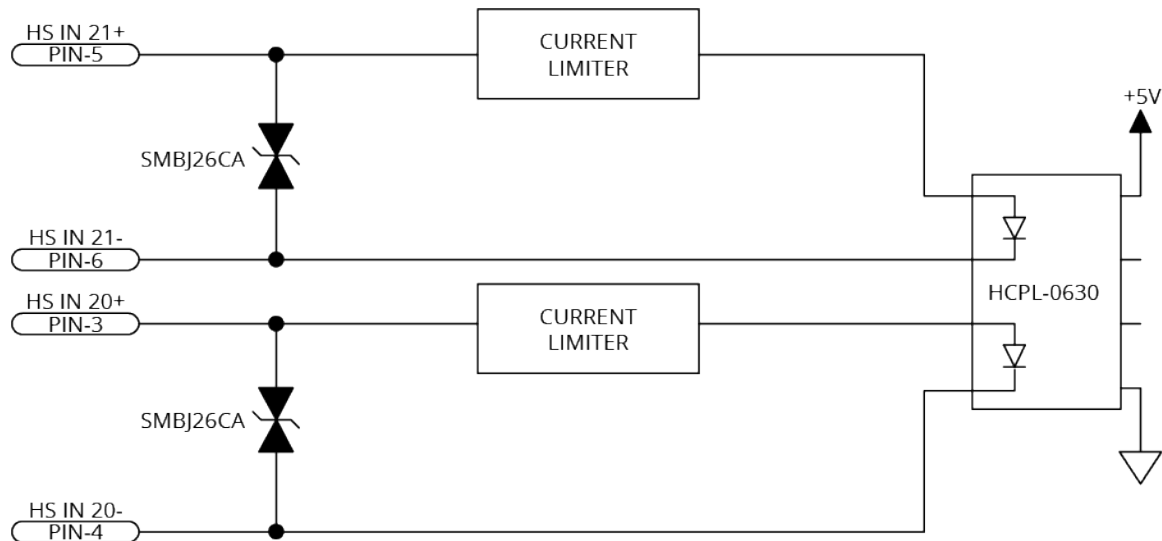

2.5.6. Analog Output 0

The analog output can be set from within a program or it can be configured to echo the state of select servo loop nodes.

The analog output is set to zero when you power on the system or reset the drive.

Table 2-47: Analog Output Specifications

Specification	Value
Output Voltage	-10 V to +10 V
Output Current	5 mA
Resolution (bits)	16 bits

Table 2-48: Analog Output Pins on the Auxiliary I/O Connector

Pin#	Description	In/Out/Bi
22	Analog Output 0	Output
23	Analog Common	Output

Figure 2-42: Analog Output 0 Schematic

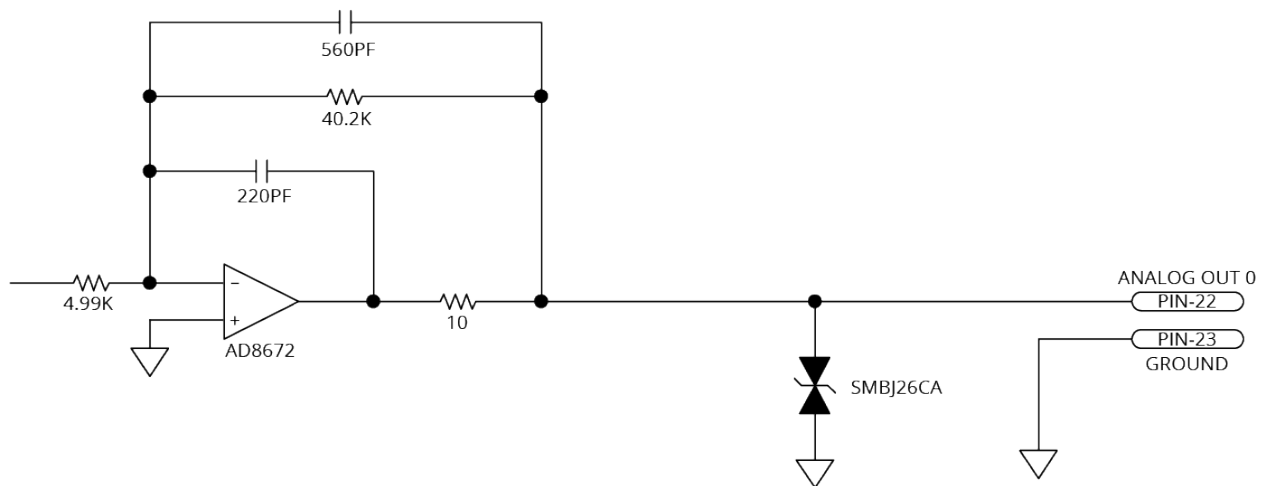

2.5.7. Analog Input 0 (Differential)

To interface to a single-ended, non-differential voltage source, connect the signal common of the source to the negative input and connect the analog source signal to the positive input. A floating signal source must be referenced to the analog common. Refer to [Figure 2-43](#).

Table 2-49: Analog Input Specifications

Specification	Value
(AI+) - (AI-)	+10 V to -10 V ⁽¹⁾
Resolution (bits)	16 bits
Input Impedance	1 MΩ

1. Signals outside of this range may damage the input

Table 2-50: Analog Input Pins on the Auxiliary I/O Connector

Pin#	Description	In/Out/Bi
13	Analog Input 0+ (Differential)	Input
14	Analog Input 0- (Differential)	Input
23	Analog Common	Output

Figure 2-43: Analog Input 0 Schematic

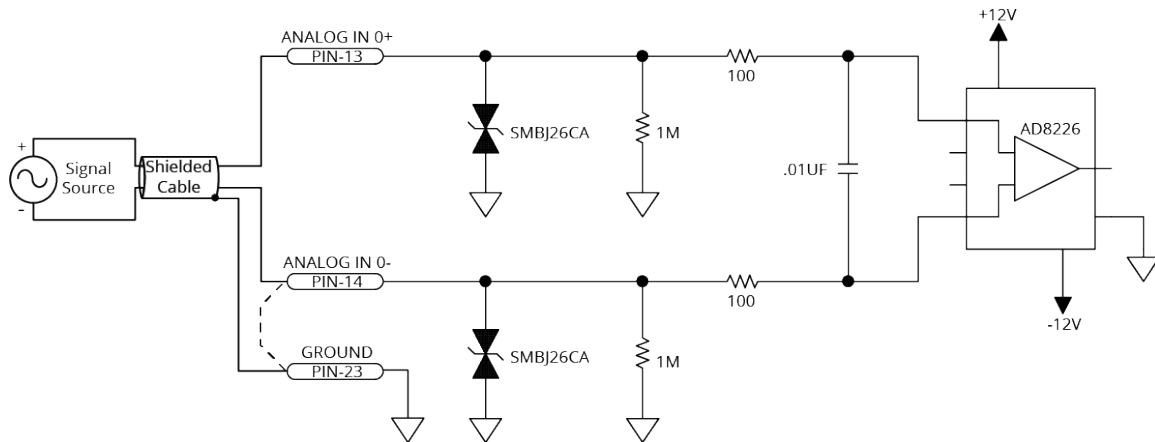

2.6. Brake Power Supply Connector

This port is the power supply connection to the on-board brake control circuit. Refer to [Section 2.3.6](#) for more information about the brake output interface.

Table 2-51: Brake Power Supply Connector Pinout

Pin#	Description	In/Out/BI	Connector
1	Brake Power Supply (+)	Input	
2	Brake Power Supply (-)	Input	

Table 2-52: Brake Power Supply Mating Connector Ratings

Specification		Description
Type		2-Pin Terminal Block
Part Numbers		Aerotech: ECK02391
		Phoenix: 1827635
Conductor Cross Section	One conductor, stranded with ferrule and plastic sleeve	18...22 AWG (0.25...0.75 mm ²)
	Two conductors (same cross-section), stranded, twin ferrule with plastic sleeve	20 AWG (0.5 mm ²)
Tightening Torque		0.22...0.25 N·m
Conductor Insulation Strip Length		7 mm (0.25 in)
(1) Refer to the manufacturer website for additional information.		

2.7. HyperWire Interface

The HyperWire bus is the high-speed communications connection from the controller. It operates at 2 gigabits per second. The controller sends all command and configuration information through the HyperWire bus. This device consumes one of the available axes of control on the HyperWire communication network. Refer to your Automation1-iSMC license for the number of available HyperWire axes.

HyperWire cables can be safely connected to or disconnected from a HyperWire port while the PC and/or drive is powered on. However, any changes to the HyperWire network topology will disrupt communication and you must reset the controller to re-establish communication.



WARNING: Do not connect or disconnect HyperWire cables while you are loading firmware or damage to the drives may occur.

Table 2-53: HyperWire Card Part Number

Part Number	Description
HYPERWIRE-PCIE	HyperWire adapter, PCIe x4 interface

Table 2-54: HyperWire Cable Part Numbers

Part Number	Description
HYPERWIRE-AO10-5	HyperWire cable, active optical, 0.5 m
HYPERWIRE-AO10-10	HyperWire cable, active optical, 1.0 m
HYPERWIRE-AO10-30	HyperWire cable, active optical, 3.0 m
HYPERWIRE-AO10-50	HyperWire cable, active optical, 5.0 m
HYPERWIRE-AO10-200	HyperWire cable, active optical, 20.0 m

2.8. Sync Port

The Sync port is a bi-directional high speed proprietary interface that lets you transmit encoder signals between drives. The drive contains two Sync ports, labeled A and B. To avoid signal contention, all Sync ports default to the input state during reset and immediately after power is applied to the drive.

This is typically used for multi-axis PSO applications where one or two drives send their encoder signals to a main drive that has the PSO logic and PSO output signal.

Table 2-55: Sync-Related Functions

Function	Description
DriveEncoderOutputConfigureDivider(), DriveEncoderOutputConfigureInput(), DriveEncoderOutputOn(), DriveEncoderOutputOff()	Configure each Sync port as an input or an output
PsoDistanceConfigureInputs()	Let the PSO track the SYNC A or SYNC B port.
PsoWindowConfigureInput()	

The Sync port uses low-voltage differential signaling (LVDS) and standard USB 3.0 type A (cross over) cables.

Table 2-56: Sync Port Cables

Part Number	Description
CBL-SYNC-3	Length 3 dm; Connectors: USB Type A to USB Type A
CBL-SYNC-5	Length 5 dm; Connectors: USB Type A to USB Type A
CBL-SYNC-7	Length 7 dm; Connectors: USB Type A to USB Type A
CBL-SYNC-10	Length 10 dm; Connectors: USB Type A to USB Type A

2.9. Industrial Ethernet (iXL5e Only)

The controller is equipped with 100BASE-TX Industrial Ethernet ports.



IMPORTANT: Industrial Ethernet is only available on the iXL5e.

- For the location of the ports, refer to [Figure 1-1](#).
- For cable part numbers, refer to [Table 4-1](#).
- For more information, refer to the Help system.

2.10. System Interconnection

Figure 2-44: Drive-Based System Wiring Drawing (Best Practice)

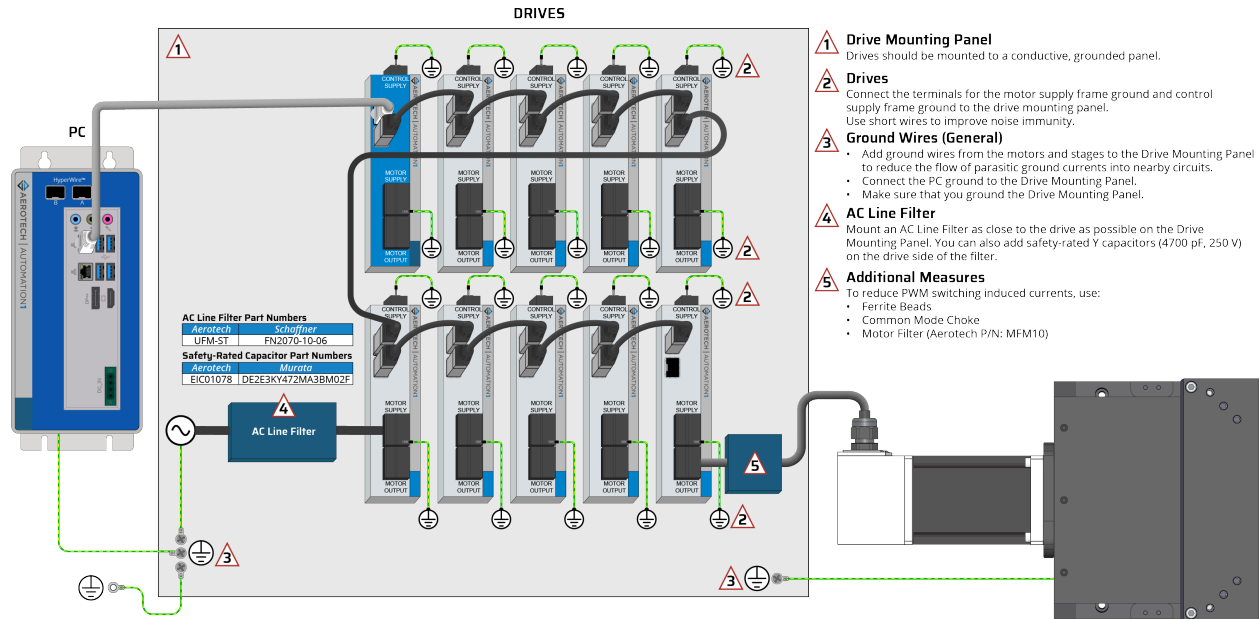

Figure 2-45: PC-Based System Wiring Drawing (Best Practice)

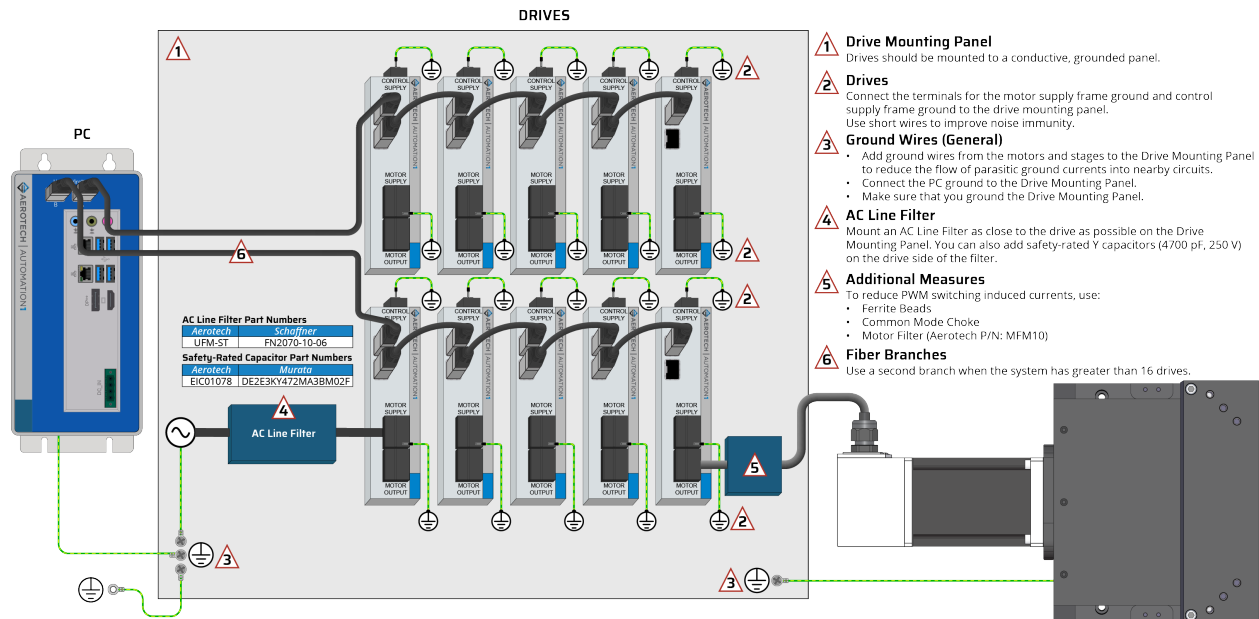
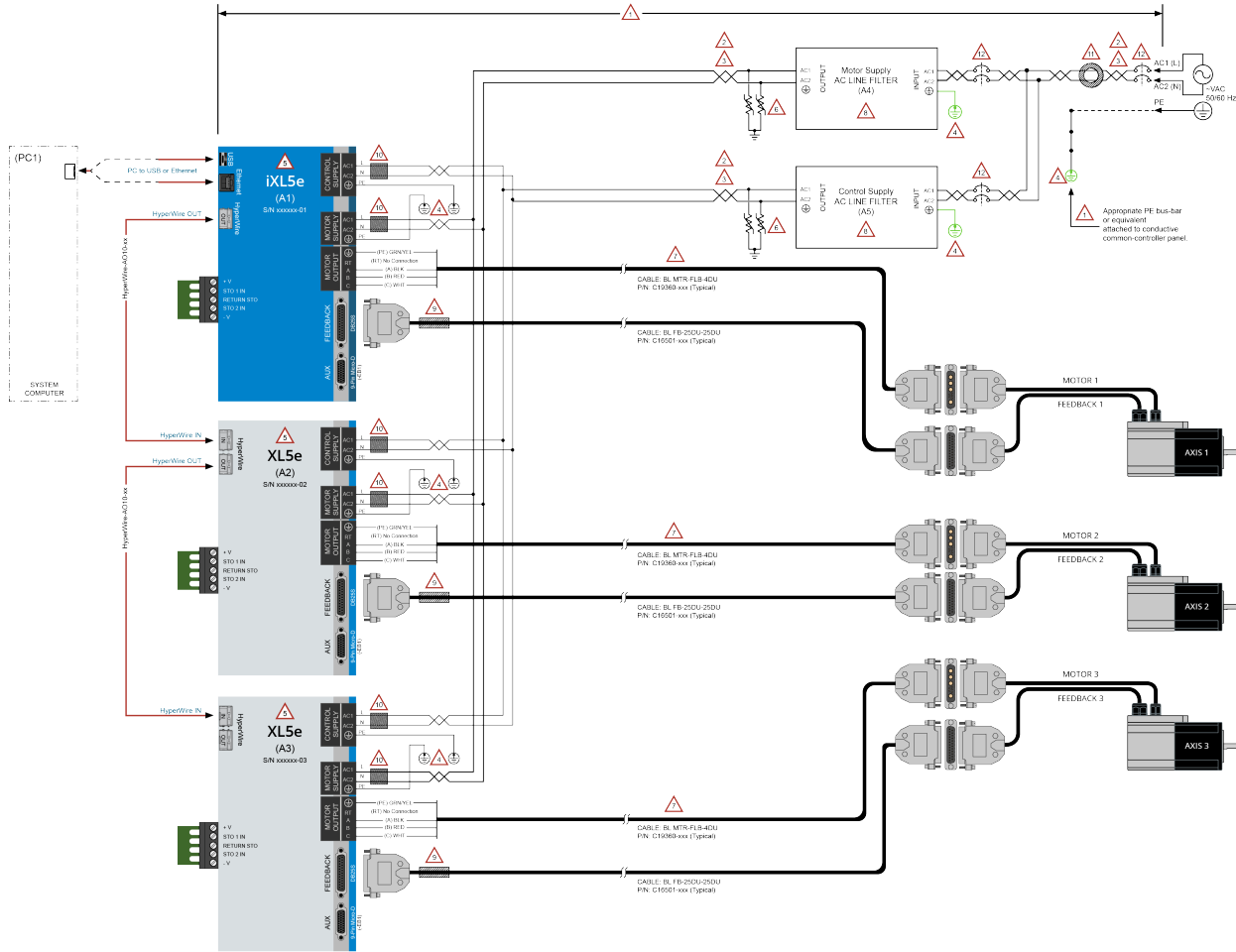
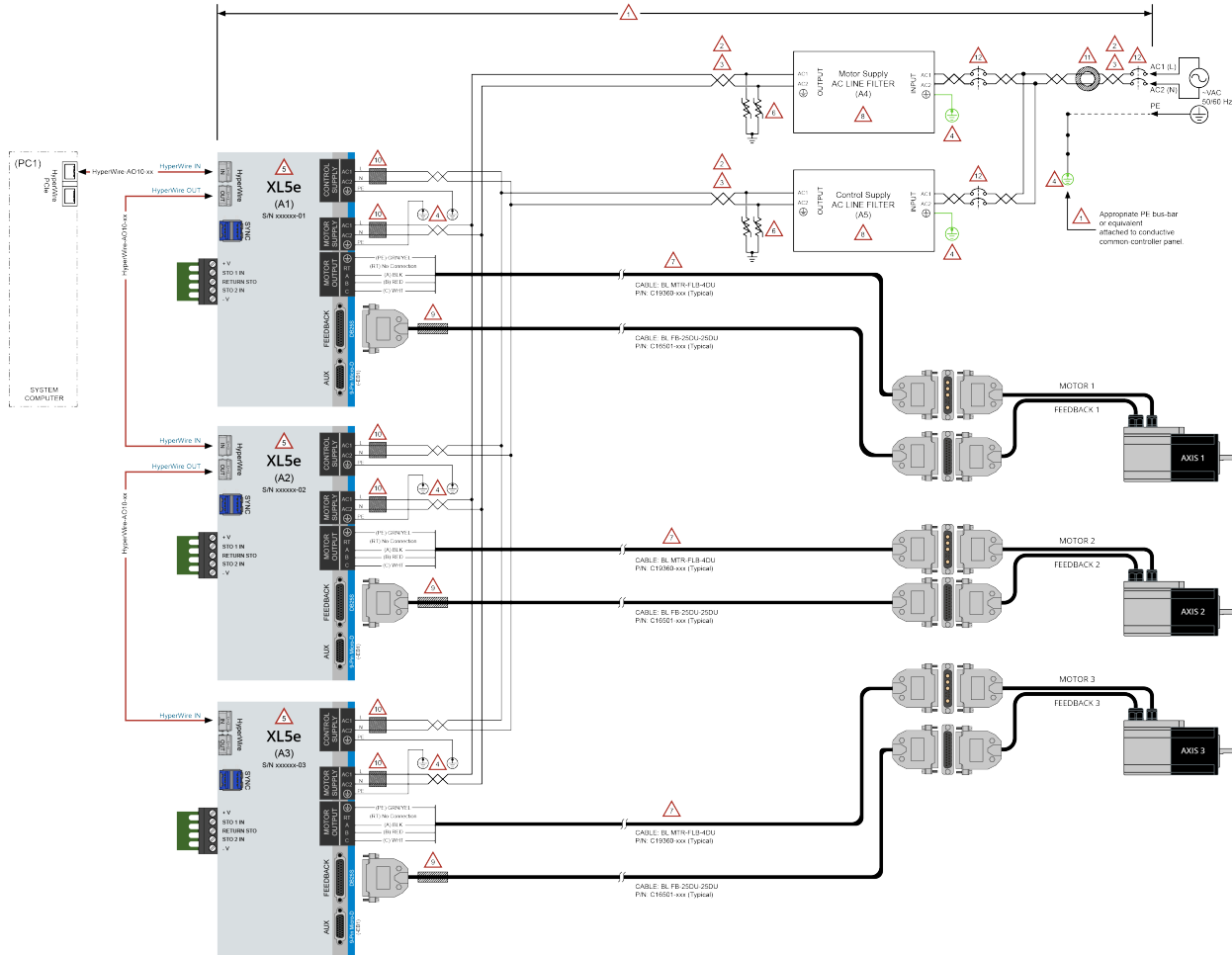

Figure 2-46: Recommended System Connections for a Drive-Based Controller



<p>! ATTENTION !</p> <p>The system integrator or end user is responsible for all safety compliance and technical requirements for the system wiring.</p> <p>IMPORTANT: Read all parts of this manual before you install or operate the drive or before you do maintenance to your system.</p> <ul style="list-style-type: none"> To prevent injury to you and damage to the equipment, obey the precautions in this manual. If you do not understand the information in this manual, contact Aerotech Global Technical Support. <p>For EMC performance, mount all system components on to a common conductive metal panel.</p> <ul style="list-style-type: none"> Do not use a panel that has a painted or non-conductive coat applied. You can use a panel with a conductive surface coat. <p>SYSTEM WIRING ROUTING</p> <ul style="list-style-type: none"> Separate VAC and VDC wiring. Separate Motor Supply wiring from Control Supply, Low-Voltage I/O, and Feedback signal wiring. <p>RECOMMENDED WIRING SPECIFICATIONS: AC SUPPLY</p> <ul style="list-style-type: none"> Use twisted pair conductors with wire lengths as short as possible. Wire Size: 1.3 mm² [18 AWG] WIRE CONFORMITY: North America (UL/ANW) / European Union (HAR/ICE). The number of axes and motor power requirements dictate the architecture of the AC power supply that may require design changes to the example illustrated. System designer must determine requirements. 	<p>SYSTEM PROTECTIVE EARTH (PE) GROUNDS</p> <ul style="list-style-type: none"> Keep PE wires as short as possible Each PE wire should have a dedicated attach/termination point Aerotech recommends that you should terminate each PE directly to the grounded component panel. Refer to Note 1 above. <p>XL5e/XL5e CONTROLLERS</p> <ul style="list-style-type: none"> Refer to assemblies (A1), (A2), and (A3) If the controllers were purchased as an integrated system, refer to the System Interconnections drawing included with the system documentation. Note that a controller's serial number is specific to an assigned axis. <p>METAL OXIDE VARISTOR (MOV) for Surge Protection (Recommended)</p> <ul style="list-style-type: none"> Required for EMC "Surge Immunity" compliance. Install one MOV to each AC1 & AC2 line as shown. Use Littelfuse P/N: V20E38P (Aerotech P/N: E120197) or equivalent NOTE: You could also use DIN-Rail mounted surge protection devices (SPDs). <p>Connect the system motor cable directly to the controller MOTOR OUTPUT terminals</p> <p>UFM-ST (Filter, AC Line Enclosure)</p> <ul style="list-style-type: none"> Refer to assemblies (A4) and (A5) For mechanical and electrical descriptions of the UFM-ST, refer to the UFM-ST Hardware Manual (UFMST.pdf) at https://www.aerotech.com/resources/manuals-help-files/. Find the manual in the Controller Accessories. <p>AXIS FEEDBACK CABLES: Ferrite EMI Filter</p> <ul style="list-style-type: none"> P/N: Fair-Rite #9446167281 (Aerotech # EC202348) Clamp-On Construction Apply as close as possible to the FEEDBACK connector as illustrated 	<p>CONTROL AND MOTOR SUPPLY EMC Filters</p> <ul style="list-style-type: none"> P/N: Fair-Rite #9446164281 (Aerotech # EC202347) Clamp-On Construction Apply as close as possible to the power connector as illustrated <p>SYSTEM AC SUPPLY FERRITE EMI FILTER</p> <ul style="list-style-type: none"> P/N: Laird #LF360233-300 (Aerotech # EC202389) Toroid Ring Construction Loop System AC1 and AC2 conductor pair two times through the toroid <p>SYSTEM AC POWER</p> <ul style="list-style-type: none"> If AC2 is not referenced to NEUTRAL, the AC2 line must have a fuse or circuit breaker protection System AC Power requirements are contingent upon the drive model and number of axes <p>The information on this page is for reference only and represents best practice applications.</p>
--	--	---

Figure 2-47: Recommended System Connections for a PC-Based Controller



<p>! ATTENTION !</p> <p>The system integrator or end user is responsible for all safety compliance and technical requirements for the system wiring.</p> <p>IMPORTANT: Read all parts of this manual before you install or operate the drive or before you do maintenance to your system.</p> <ul style="list-style-type: none"> - To prevent injury to you and damage to the equipment, obey the precautions in this manual. - If you do not understand the information in this manual, contact Aerotech Global Technical Support. <p>For EMC performance, mount all system components on to a common conductive metal panel.</p> <ul style="list-style-type: none"> - Do not use a panel that has a painted or non-conductive coat applied. - You can use a panel with a conductive surface coat. <p>SYSTEM WIRING ROUTING</p> <ul style="list-style-type: none"> - Separate I/O and VDC wiring. - Separate Motor Supply wiring from Control Supply, Low-Voltage I/O, and Feedback signal wiring. <p>RECOMMENDED WIRING SPECIFICATIONS: AC SUPPLY</p> <ul style="list-style-type: none"> - Use twisted pair conductors with wire lengths as short as possible. - Wire Size: 1.3 mm² [18 AWG] <p>WIRE CONFORMITY: North America (UL ANNA) / European Union (HARV-ICE). The number of axes and motor power requirements dictate the architecture of the AC power supply that may require design changes to the example illustrated. System designer must determine requirements.</p>	<p>SYSTEM PROTECTIVE EARTH (PE) GROUNDS</p> <ul style="list-style-type: none"> - Keep PE wires as short as possible. - Each PE wire should have a dedicated attachment/termination point. - Aerotech recommends that you should terminate each PE directly to the grounded component panel. Refer to Note 1 above. <p>XL5e CONTROLLERS</p> <ul style="list-style-type: none"> - Refer to assemblies (A1), (A2), and (A3). - If the controllers were purchased as an integrated system, refer to the System Interconnections drawing included with the system documentation. Note that a controller's serial number is specific to an assigned axis. <p>METAL OXIDE VARISTOR (MOV) for Surge Protection (Recommended)</p> <ul style="list-style-type: none"> - Required for EMC "Surge Immunity" compliance. - Install one MOV to each AC1 & AC2 line as shown. - Use: Littelfuse P/N: V20E385P (Aerotech P/N: EID00197) or equivalent. - NOTE: You could also use DIN-Rail mounted surge protection devices (SPDs). <p>Connect the system motor cable directly to the controller MOTOR OUTPUT terminals.</p> <p>ULM-ST (Filter: AC Line Enclosure)</p> <ul style="list-style-type: none"> - Refer to assemblies (A4) and (A5). - For mechanical and electrical descriptions of the ULM-ST, refer to the ULM-ST Hardware Manual (ULM-ST.pdf) at https://www.aerotech.com/resources-manuals-help-files/. Find the manual in the Controller-Accessories. <p>Axis FEEDBACK cable ferrite EMC filters</p> <ul style="list-style-type: none"> - P/N: Fair-Rite #3445167281 (Aerotech # EC202346) - Clamp-On Construction. - Apply as close as possible to the FEEDBACK connector as illustrated. 	<p>CONTROL AND MOTOR SUPPLY EMC Filters</p> <ul style="list-style-type: none"> - P/N: Fair-Rite #0446154281 (Aerotech # EC202347) - Clamp-On Construction. - Apply as close as possible to the power connector as illustrated. <p>SYSTEM AC SUPPLY FERRITE EMC FILTER</p> <ul style="list-style-type: none"> - P/N: Laird # F8360235-300 (Aerotech # EC202398) - Toroid Ring Construction. - Loop System AC1 and AC2 conductor pair two times through the toroid. <p>SYSTEM AC POWER</p> <ul style="list-style-type: none"> - If AC2 is not referenced to NEUTRAL, the AC2 line must have a fuse or circuit breaker protection. - System AC Power requirements are contingent upon the drive model and number of axes. <p>The information on this page is for reference only and represents best practice applications.</p>
--	--	--

2.11. PC Configuration and Operation Information

For more information about hardware requirements, PC configuration, programming, system operation, and utilities, refer to the Help file.

This page intentionally left blank.

Chapter 3: -EB1 Option Expansion Board

The -EB1 I/O option board has 16 digital inputs, 16 digital outputs, 3 analog inputs, 3 analog outputs, and PSO outputs.

Figure 3-1: -EB1 I/O Option Board Connectors (iXL5e shown)

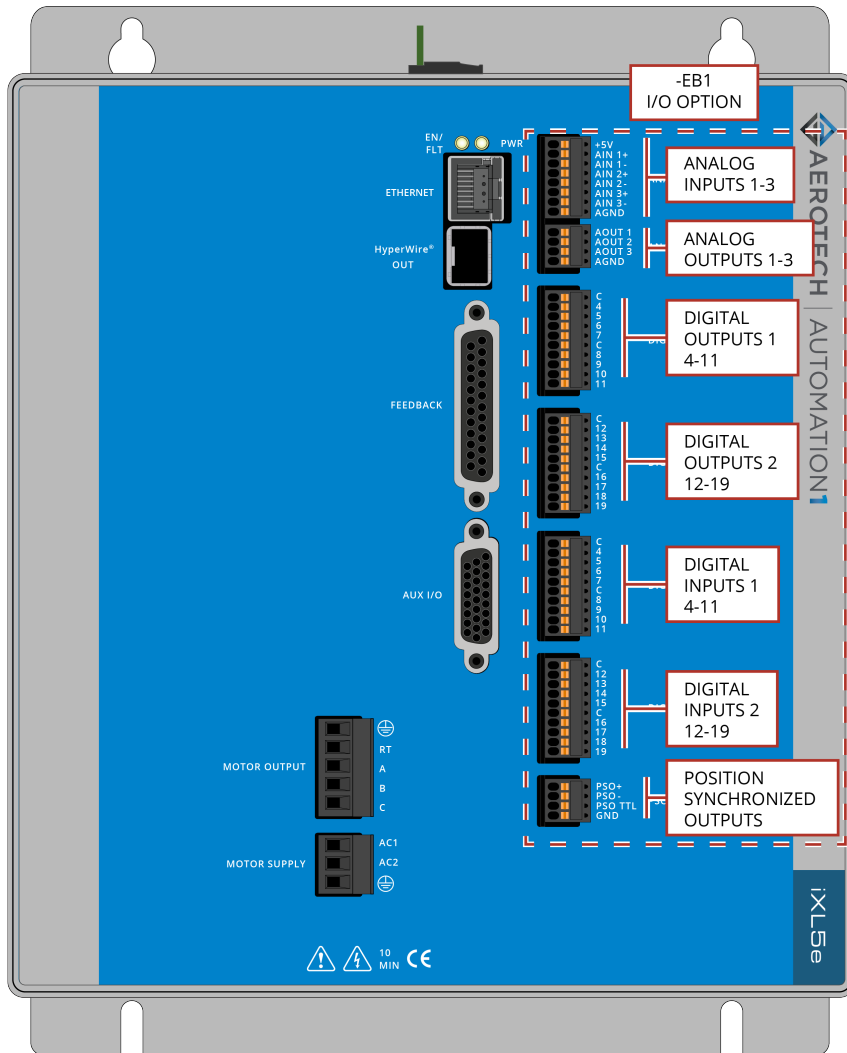

3.1. Digital Outputs [-EB1]

Optically-isolated solid-state relays drive the digital outputs. You can connect the digital outputs in current sourcing or current sinking mode but you must connect all four outputs in a port in the same configuration. Refer to [Figure 3-3](#) and [Figure 3-4](#).

The digital outputs are not designed for high-voltage isolation applications and they should only be used with ground-referenced circuits.

You must install suppression diodes on digital outputs that drive relays or other inductive devices. To see an example of a current sourcing output that has diode suppression, refer to [Figure 3-3](#). To see an example of a current sinking output that has diode suppression, refer to [Figure 3-4](#).

The digital outputs have overload protection. They will resume normal operation when the overload is removed.

Table 3-1: Digital Output Specifications [-EB1]

Digital Output Specifications	Value
Maximum Voltage	24 V (26 V Maximum)
Maximum Sink/Source Current	250 mA/output
Output Saturation Voltage	0.9 V at maximum current
Output Resistance	3.7 Ω
Rise / Fall Time	250 μ s (2K pull up to 24V)
Reset State	Output Off (High Impedance State)

Table 3-2: Digital Output 1 Connector Pinout [-EB1]

Pin#	Description	In/Out/Bi	Connector
1	Output Common for Outputs 4-7	Output	
2	Output 4 (Optically-Isolated)	Output	
3	Output 5 (Optically-Isolated)	Output	
4	Output 6 (Optically-Isolated)	Output	
5	Output 7 (Optically-Isolated)	Output	
6	Output Common for Outputs 8-11	Output	
7	Output 8 (Optically-Isolated)	Output	
8	Output 9 (Optically-Isolated)	Output	
9	Output 10 (Optically-Isolated)	Output	
10	Output 11 (Optically-Isolated)	Output	

Table 3-3: Digital Output 2 Connector Pinout [-EB1]

Pin#	Description	In/Out/Bi	Connector
1	Output Common for Outputs 12-15	Output	
2	Output 12 (Optically-Isolated)	Output	
3	Output 13 (Optically-Isolated)	Output	
4	Output 14 (Optically-Isolated)	Output	
5	Output 15 (Optically-Isolated)	Output	
6	Output Common for Outputs 16-19	Output	
7	Output 16 (Optically-Isolated)	Output	
8	Output 17 (Optically-Isolated)	Output	
9	Output 18 (Optically-Isolated)	Output	
10	Output 19 (Optically-Isolated)	Output	

Table 3-4: Digital Output 1 and 2 Mating Connector Ratings [-EB1]

Specification		Description
Type		10-Pin Terminal Block
Part Numbers		Aerotech: ECK02395
		Phoenix: 1700841
Conductor Cross Section	Solid or stranded	20...26 AWG (0.14...0.5 mm ²)
	Stranded, with ferrule, without plastic sleeve	20...24 AWG (0.25...0.5 mm ²)
Conductor Insulation Strip Length		8 mm (5/16 in)
(1) Refer to the manufacturer website for additional information.		

Figure 3-2: Digital Outputs Schematic [-EB1]

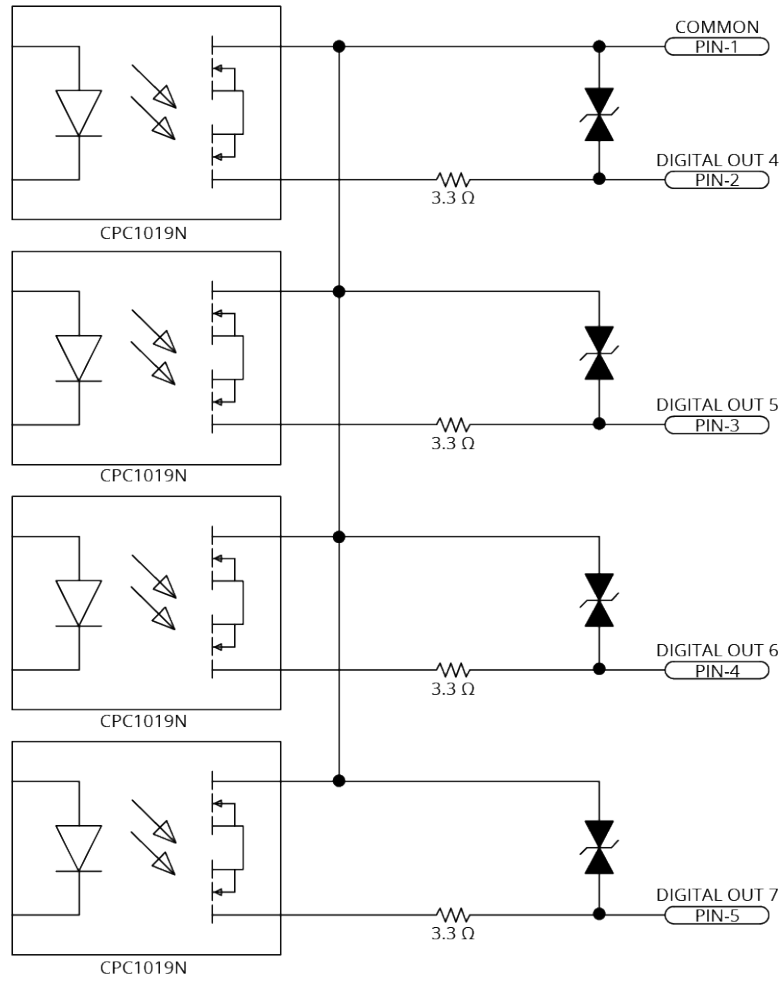
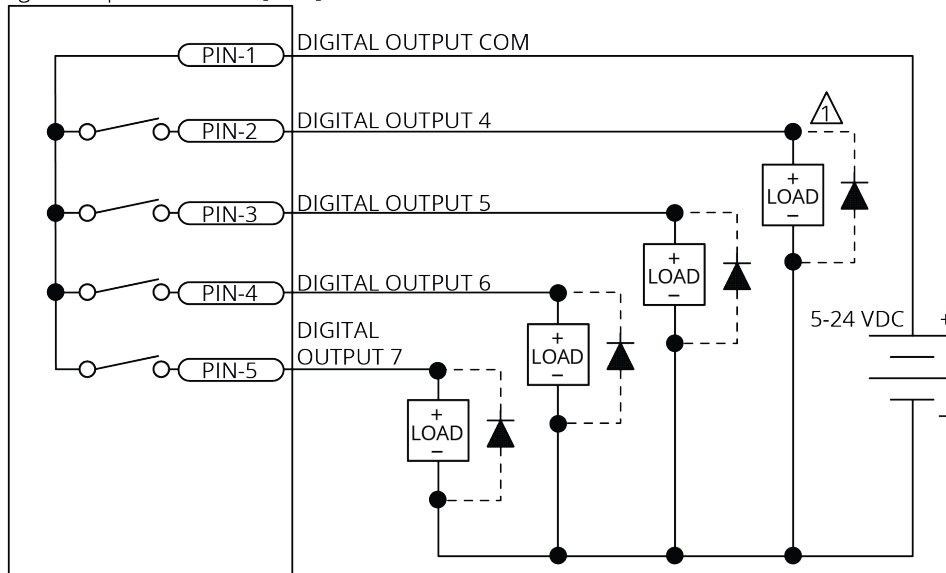

Figure 3-3: Digital Outputs Connected in Current Sourcing Mode [-EB1]

Digital Output Connector [-EB1]



 DIODE REQUIRED ON EACH OUTPUT THAT DRIVES AN INDUCTIVE DEVICE (COIL), SUCH AS A RELAY.

Figure 3-4: Digital Outputs Connected in Current Sinking Mode [-EB1]

Digital Output Connector [-EB1]

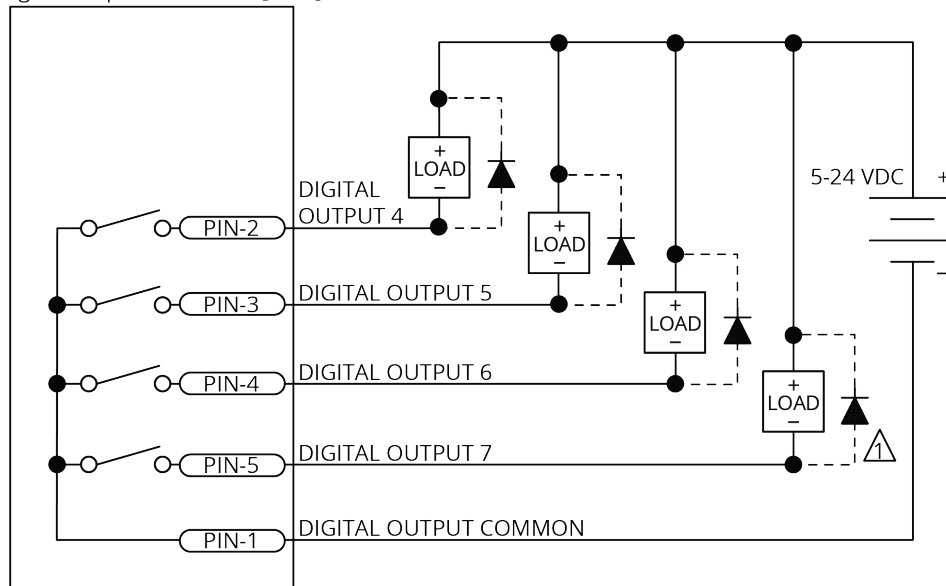

 DIODE REQUIRED ON EACH OUTPUT THAT DRIVES AN INDUCTIVE DEVICE (COIL), SUCH AS A RELAY.

3.2. Digital Inputs [-EB1]

Input bits are arranged in groups of 4 and each group shares a common pin. This lets a group be connected to current sourcing or current sinking devices, based on the connection of the common pin in that group.

To be able to connect an input group to current sourcing devices, connect the input group's common pin to the power supply return (-). Refer to [Figure 3-6](#).

To be able to connect an input group to current sinking devices, connect the input group's common pin to the power supply source (+). Refer to [Figure 3-7](#).

The digital inputs are not designed for high-voltage isolation applications. They should only be used with ground-referenced circuits.

Table 3-5: Digital Input Specifications [-EB1]

Input Voltage	Approximate Input Current	Turn On Time	Turn Off Time
+5 V to +24 V	6 mA	10 μ s	43 μ s

Table 3-6: Digital Input 1 Connector Pinout [-EB1]

Pin#	Description	In/Out/Bi	Connector
1	Input Common for Inputs 4-7	Output	
2	Input 4 (Optically-Isolated)	Input	
3	Input 5 (Optically-Isolated)	Input	
4	Input 6 (Optically-Isolated)	Input	
5	Input 7 (Optically-Isolated)	Input	
6	Input Common for Inputs 8-11	Output	
7	Input 8 (Optically-Isolated)	Input	
8	Input 9 (Optically-Isolated)	Input	
9	Input 10 (Optically-Isolated)	Input	
10	Input 11 (Optically-Isolated)	Input	

Table 3-7: Digital Input 2 Connector Pinout [-EB1]

Pin#	Description	In/Out/Bi	Connector
1	Input Common for Inputs 12-15	Output	
2	Input 12 (Optically-Isolated)	Input	
3	Input 13 (Optically-Isolated)	Input	
4	Input 14 (Optically-Isolated)	Input	
5	Input 15 (Optically-Isolated)	Input	
6	Input Common for Inputs 16-19	Output	
7	Input 16 (Optically-Isolated)	Input	
8	Input 17 (Optically-Isolated)	Input	
9	Input 18 (Optically-Isolated)	Input	
10	Input 19 (Optically-Isolated)	Input	

Table 3-8: Digital Input 1 and 2 Mating Connector Ratings [-EB1]

Specification		Description
Type		10-Pin Terminal Block
Part Numbers		Aerotech: ECK02395 Phoenix: 1700841
Conductor Cross Section	Solid or stranded	20...26 AWG (0.14...0.5 mm ²)
	Stranded, with ferrule, without plastic sleeve	20...24 AWG (0.25...0.5 mm ²)
Conductor Insulation Strip Length		8 mm (5/16 in)
(1) Refer to the manufacturer website for additional information.		

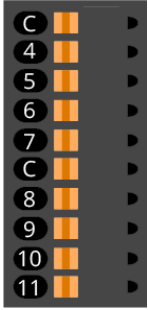
Figure 3-5: Digital Inputs Schematic [-EB1]

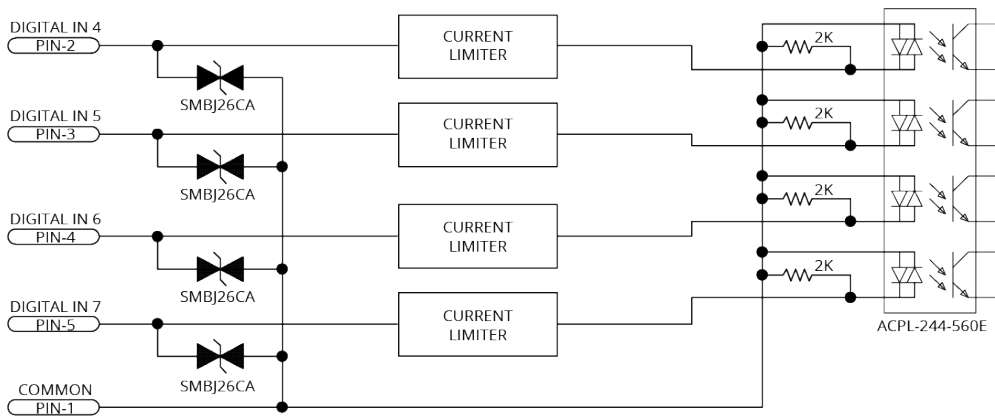



IMPORTANT: Each bank of four inputs must be connected in an all sourcing or all sinking configuration.

Figure 3-6: Digital Inputs Connected to Current Sourcing (PNP) Devices [-EB1]

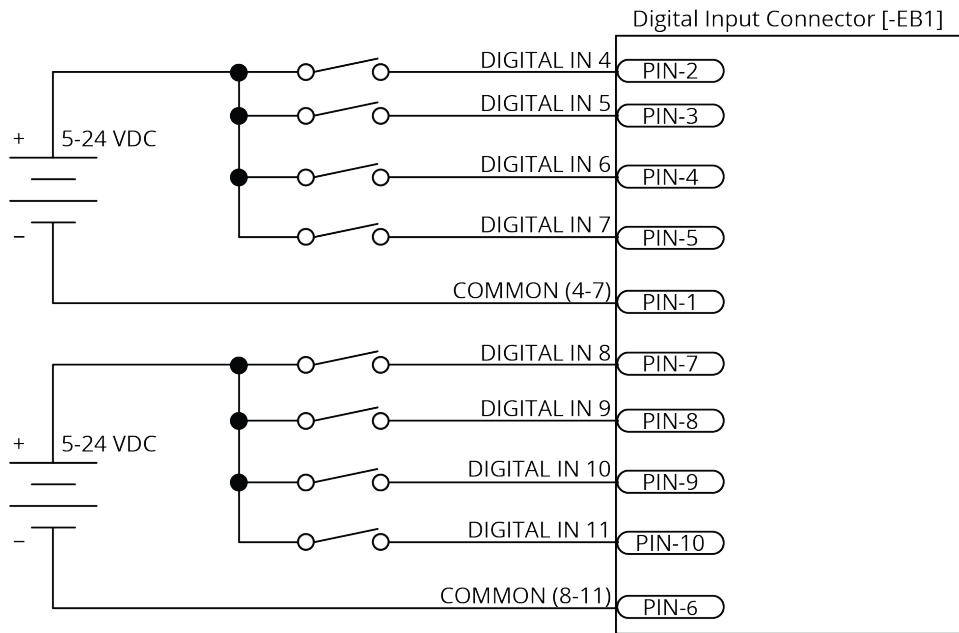
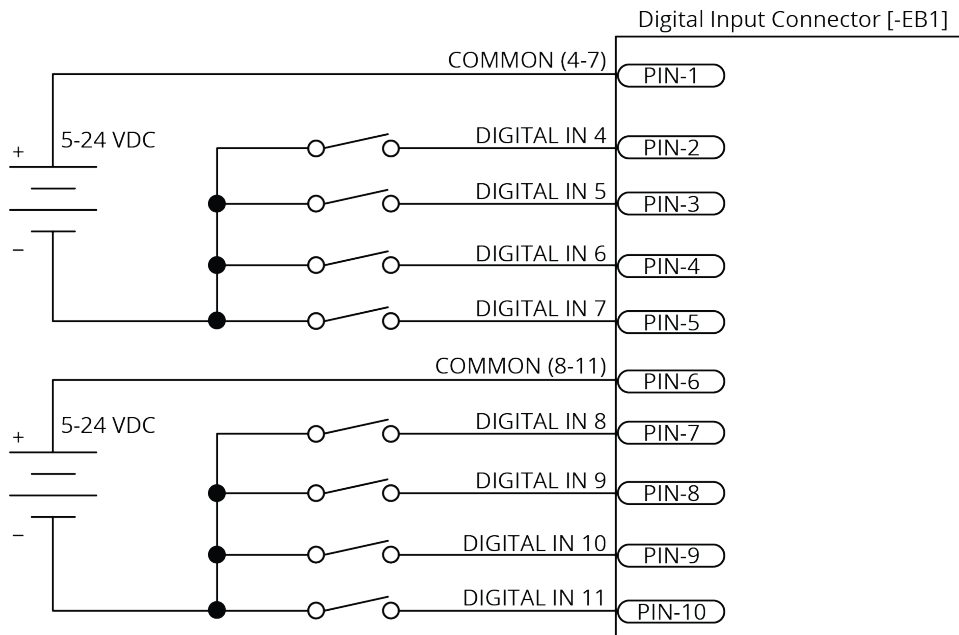

Figure 3-7: Digital Inputs Connected to Current Sinking (NPN) Devices [-EB1]



3.3. Analog Outputs [-EB1]

The analog outputs can be set from within a program or they can be configured to echo the state of select servo loop nodes.

The analog outputs are set to zero when you power on the system or reset the drive.

Table 3-9: Analog Output Specifications [-EB1]

Specification	Value
Output Voltage	-10 V to +10 V
Output Current	5 mA
Resolution (bits)	16 bits

Table 3-10: Analog Output Connector Pinout [-EB1]

Pin #	Description	In/Out/Bi	Connector
1	Analog Output 1	Output	
2	Analog Output 2	Output	
3	Analog Output 3	Output	
4	Ground	N/A	

Table 3-11: Analog Output Mating Connector Ratings [-EB1]

Specification	Description
Type	4-Pin Terminal Block
Part Numbers	Aerotech: ECK02399
	Phoenix: 1768004
Conductor Cross Section	Solid or stranded
	Stranded, with ferrule, without plastic sleeve
Conductor Insulation Strip Length	8 mm (5/16 in)

(1) Refer to the manufacturer website for additional information.

Figure 3-8: Analog Output Typical Connection [-EB1]

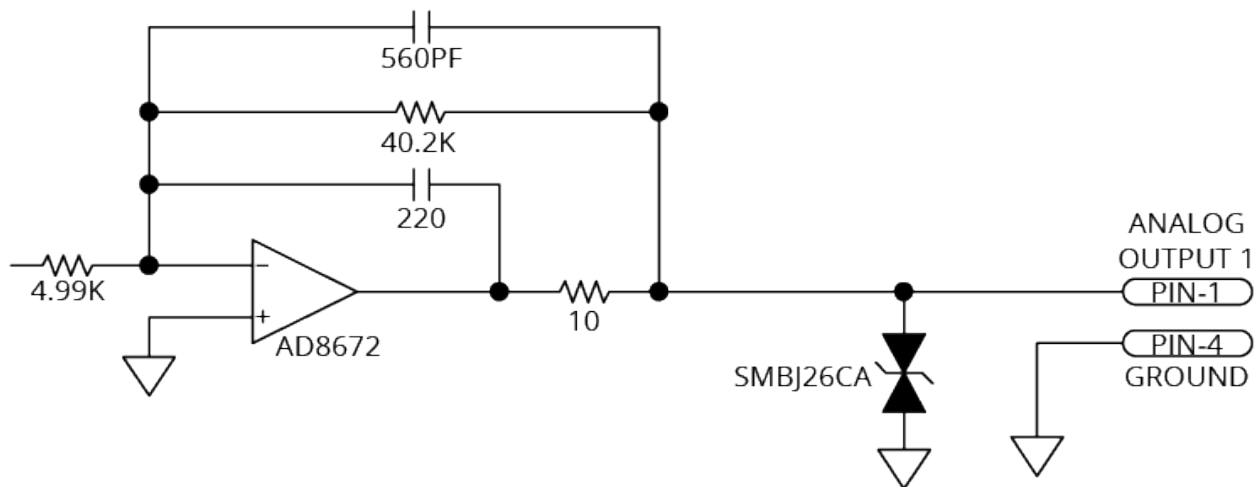

3.4. Analog Inputs [-EB1]

To interface to a single-ended, non-differential voltage source, connect the signal common of the source to the negative input and connect the analog source signal to the positive input. A floating signal source must be referenced to the analog common. Refer to [Figure 3-9](#).

Table 3-12: Differential Analog Input Specifications [-EB1]

Specification	Value
(AI+) - (AI-)	+10 V to -10 V ⁽¹⁾
Resolution (bits)	16 bits
Input Impedance	1 MΩ
1. Signals outside of this range may damage the input	

Table 3-13: Analog Input Connector Pinout [-EB1]

Pin#	Description	In/Out/Bi	Connector
1	+5V (250 mA max)	Output	
2	Analog Input 1+	Input	
3	Analog Input 1-	Input	
4	Analog Input 2+	Input	
5	Analog Input 2-	Input	
6	Analog Input 3+	Input	
7	Analog Input 3-	Input	
8	Ground	N/A	

Table 3-14: Analog Input Mating Connector Ratings [-EB1]

Specification	Description
Type	8-Pin Terminal Block
Part Numbers	Aerotech: ECK02397
	Phoenix: 1908101
Conductor Cross Section	Solid or stranded
	Stranded, with ferrule, without plastic sleeve
Conductor Insulation Strip Length	8 mm (5/16 in)
(1) Refer to the manufacturer website for additional information.	

Figure 3-9: Analog Input Typical Connection [-EB1]

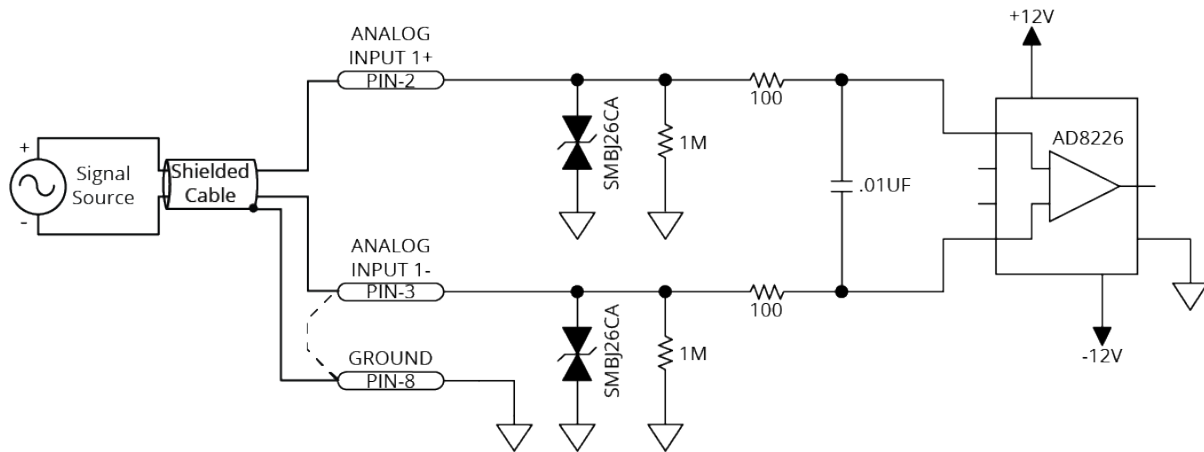

3.5. PSO Interface [-EB1]

The Position Synchronized Output (PSO) signal is available on the -EB1 option board in two signal formats: TTL and Isolated.

The PSO signal is also available on the AUX I/O connector. Refer to [Section 2.5.2](#).

Table 3-15: PSO Specifications [-EB1]

Specification		Value
Output	TTL	5 V, 16 mA (max)
	Isolated	5-24 V, 250 mA
Maximum PSO Output (Fire) Frequency	TTL	12.5 MHz
	Isolated	5 MHz
Output Latency [Fire event to output change]	TTL	15 ns
	Isolated	160 ns

Table 3-16: PSO Interface Connector Pinout [-EB1]

Pin #	Description	In/Out/Bi	Connector
1	PSO Output+	Output	
2	PSO Output-	Output	
3	PSO Output (TTL)	Output	
4	Ground	N/A	

Table 3-17: PSO Interface Mating Connector Ratings [-EB1]

Specification		Description
Type		4-Pin Terminal Block
Part Numbers		Aerotech: ECK02399
		Phoenix: 1768004
Conductor Cross Section	Solid or stranded	20...26 AWG (0.14...0.5 mm ²)
	Stranded, with ferrule, without plastic sleeve	20...24 AWG (0.25...0.5 mm ²)
Conductor Insulation Strip Length		8 mm (5/16 in)
(1) Refer to the manufacturer website for additional information.		

Isolated Signals

This output signal is a fully-isolated 5-24V compatible output capable of sourcing or sinking current. This output is normally open and only conducts current when a PSO fire event occurs.

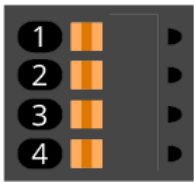
The PSO Isolated Outputs are overload protected and will turn off if the maximum output current is exceeded.

Figure 3-10: PSO Output Sources Current

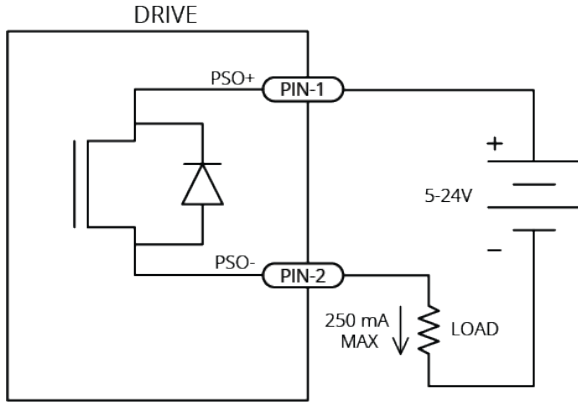
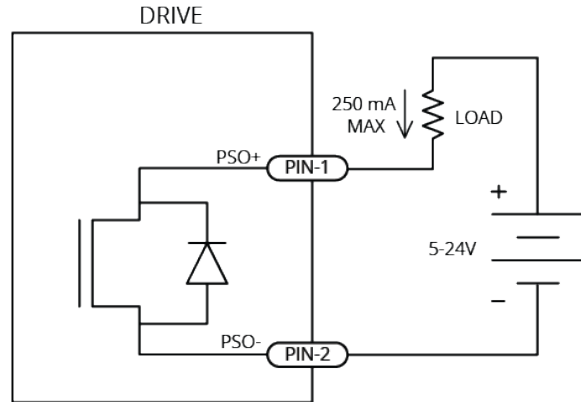

Figure 3-11: PSO Output Sinks Current



TTL Signals

This output signal is a 5V TTL signal which is used to drive an opto coupler or general purpose TTL input. This signal is active high and is driven to 5V when a PSO fire event occurs.

Figure 3-12: PSO TTL Outputs Schematic

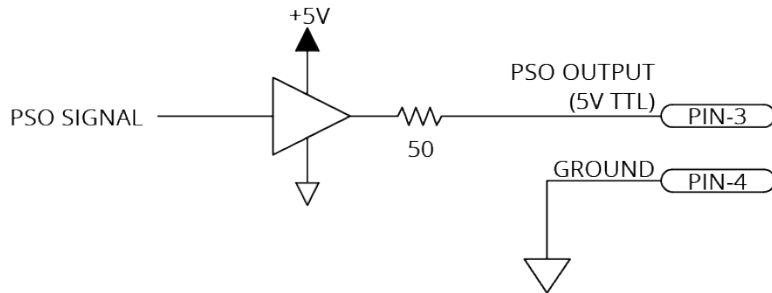

Chapter 4: Cables and Accessories

Table 4-1: Standard Interconnection Cables

Cable Part #	Description
Joystick	Refer to Section 4.1 .
HyperWire	Refer to Section 2.7 .
ECZ01231	BBA32 Interconnect Cable
ENET-CAT5e-xx ^(1, 2)	Ethernet CAT5e Cable
USB-AMCM-xx ^(1, 2, 3)	USB Cable A-Male to C-Male
<p>(1) The "-xx" indicates length in decimeters. (2) iXL5e Only (3) Make sure that you are using a shielded USB-C cable that is designed for data transfer.</p>	

4.1. Joystick Interface

Aerotech Multi-Axis Joystick (NEMA12 (IP54) rated) is powered from 5 V and has a nominal 2.5 V output in the center detent position. Three buttons are used to select axis pairs and speed ranges. An optional interlock signal is used to indicate to the controller that the joystick is present. Joystick control will not activate unless the joystick is in the center location. Third party devices can be used provided they produce a symmetric output voltage within the range of -10 V to +10 V.

Connecting joystick with an Aerotech cable, all Aerotech cables are labeled to identify the connector and connections. The joystick parameters must be set to match the analog and digital I/O connections. Refer to the Help file for programming information about how to change joystick parameters.

Figure 4-1: Two Axis Joystick Interface (to the Aux I/O of two drives)

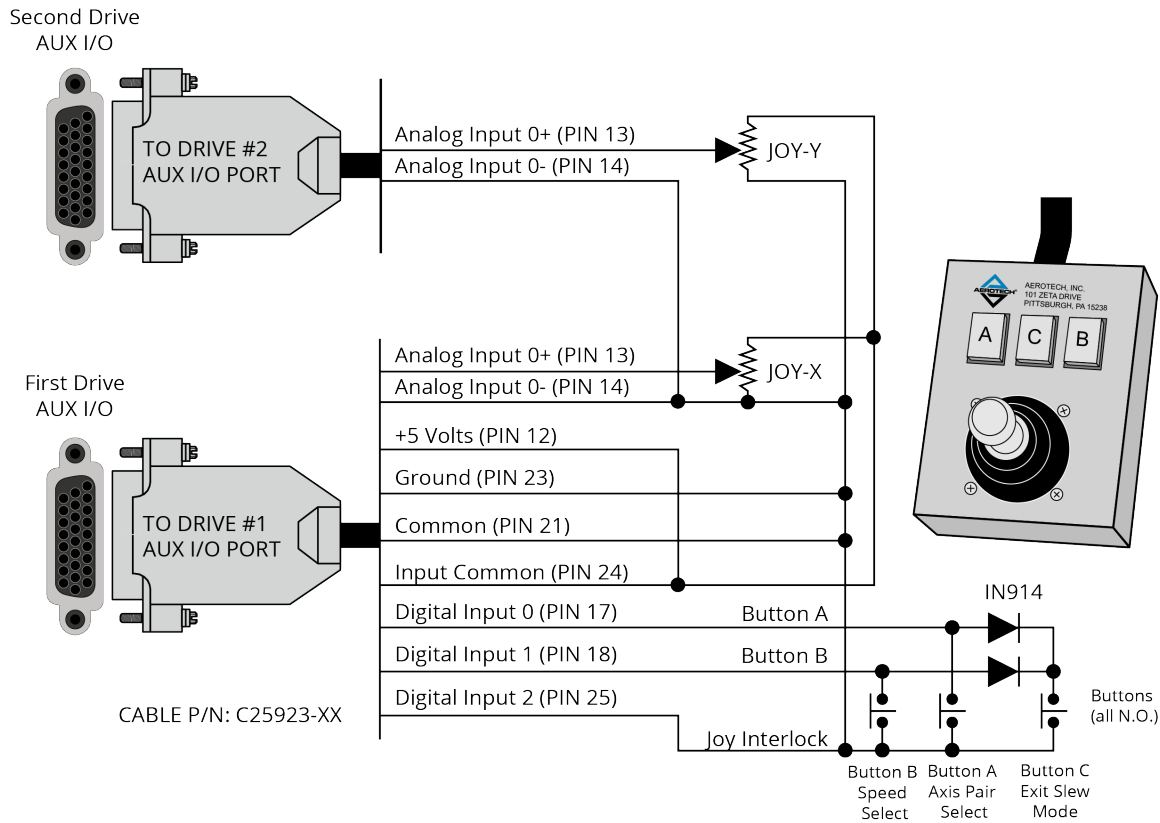
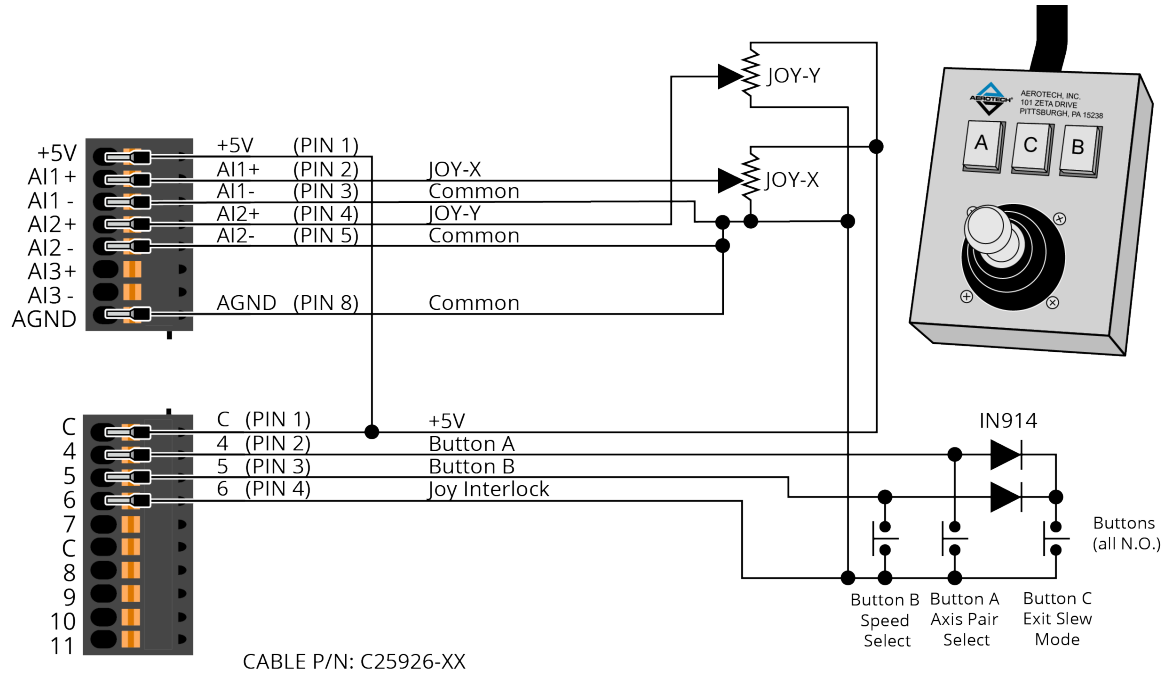

Figure 4-2: Two Axis Joystick Interface (to the I/O board)



4.2. Handwheel Interface

A handwheel can be used to manually control axis position. The handwheel must provide 5V differential quadrature signals to the drive.



IMPORTANT: You can find instructions on how to enable the handwheel in the online Help file.

Connect a handwheel to the Aux I/O as shown in [Figure 4-3](#) or [Figure 4-4](#).

Figure 4-3: Handwheel Interconnection to Aux I/O Connector

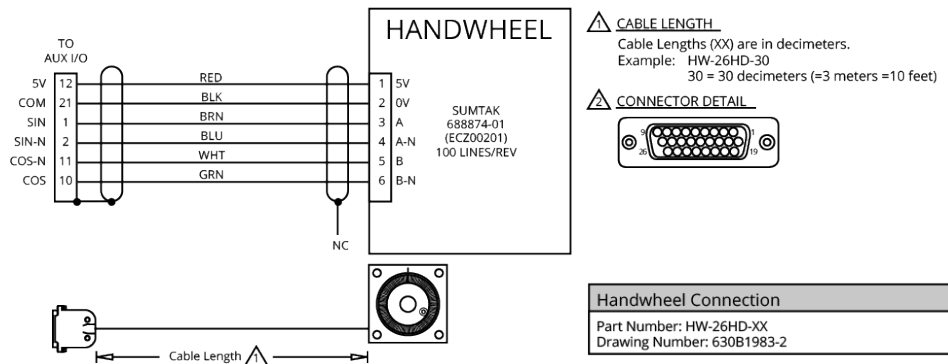
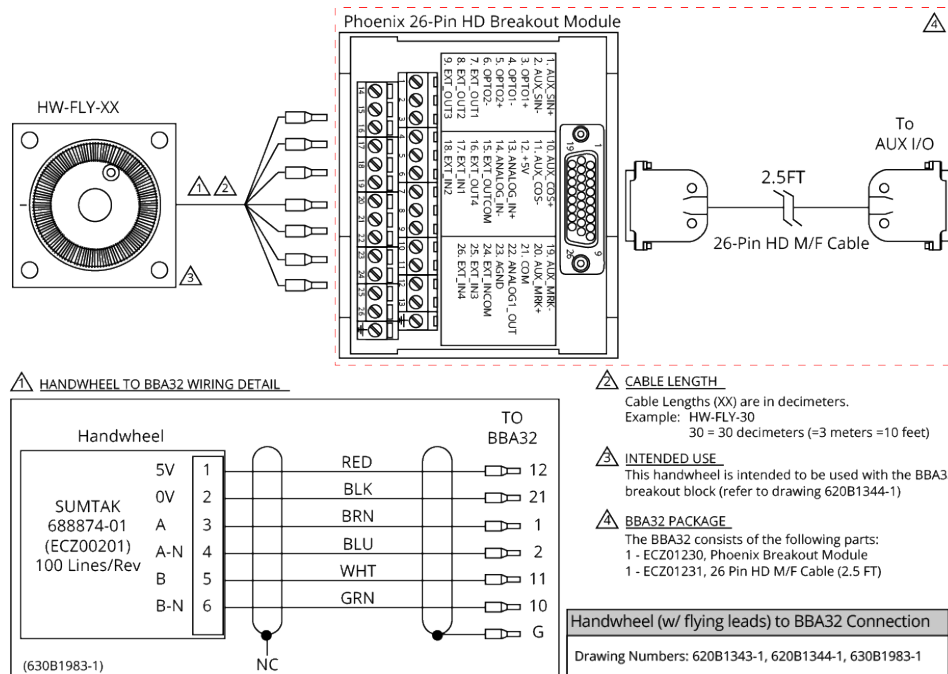

Figure 4-4: Handwheel Interconnection to the Aux I/O through a BBA32 Module



Chapter 5: Maintenance



IMPORTANT: For your own safety and for the safety of the equipment:

- Do not remove the cover of the iXL5e/XL5e.
- Do not attempt to access the internal components.

A fuse that needs to be replaced indicates that there is a more serious problem with the system or setup. Contact Global Technical Support for assistance.



DANGER: If you must remove the covers and access any internal components be aware of the risk of electric shock.

1. Disconnect the Mains power connection.
2. Wait at least ten (10) minutes after removing the power supply before doing maintenance or an inspection. Otherwise, there is the danger of electric shock.
3. All tests must be done by an approved service technician. Voltages inside the controller and at the input and output power connections can kill you.

Table 5-1: LED Description

LED	Color	Description
PWR	GREEN	The axis is powered on.
	RED ⁽¹⁾	The light will turn red when power is first applied, a communication problem occurs, or a drive reset is initiated. It will remain red during drive initialization.
EN/FLT	GREEN	The axis is Enabled.
	RED	The axis is in a Fault Condition.
	GREEN/RED (alternates)	The axis is Enabled in a Fault Condition. or The light is configured to blink for setup.

(1) Red PWR LED functionality is only present on some versions of the drive.

Table 5-2: Troubleshooting

Symptom	Possible Cause and Solution
No Communication	Make sure the power LED is illuminated (this indicates that power is present).
	Make sure that all communication cables (HyperWire, for example) are fully inserted in their ports.

5.1. Preventative Maintenance

Do an inspection of the iXL5e/XL5e and the external wiring one time each month. It might be necessary to do more frequent inspections based on:

- The operating conditions of the system.
- How you use the system.

Table 5-3: Preventative Maintenance

Check	Action to be Taken
Examine the chassis for hardware and parts that are damaged or loose. It is not necessary to do an internal inspection unless you think internal damage occurred.	Repair all damaged parts.
Do an inspection of the cooling vents.	Remove all material that collected in the vents.
Examine the work area to make sure there are no fluids and no electrically conductive materials.	Do not let fluids and electrically conductive material go into the chassis.
Examine all cables and connections to make sure they are correct.	Make sure that all connections are correctly attached and not loose. Replace cables that are worn. Replace all broken connectors.

Cleaning



DANGER: Before you clean the iXL5e/XL5e, disconnect the electrical power from the drive.

Use a clean, dry, soft cloth to clean the iXL5e/XL5e. If necessary, use a cloth that is moist with water or isopropyl alcohol. If you use a moist cloth, make sure that moisture does not go into the drive. Also make sure that it does not go onto the outer connectors and components. Internal contamination from the cleaning solution can cause corrosion and electrical short circuits.

Do not clean the labels with a cleaning solution because it might remove the label information.

5.2. Fuse Specifications



WARNING: Replace fuses only with the same type and value.

Table 5-4: Fuse Specifications

Fuse	Description	Size	SCCR ⁽¹⁾	Aerotech P/N	Third Party P/N
F100	Control Supply at Line Input (L)	2 A S.B.	35 A	EIF01044	Littelfuse 0877002.MXEP
F4	Motor Supply at AC1 (200 VAC/240 VAC)	7 A S.B.	200 A	EIF00107	Littelfuse 313007.HXP
F5	Motor Supply at AC1 (100 VAC/120 VAC)	8 A S.B.	1500 A	EIF01022	Littelfuse 0215008.HXP
F6	XL5e-10: Motor Bus Voltage Negative	5 A S.B.	1500 A	EIR01023	Littelfuse 0215005.HXP
	XL5e-20: Motor Bus Voltage Negative	10 A S.B.	1500 A	EIR01020	Littelfuse 0215010.HXP
F7	XL5e-10: Motor Bus Voltage Positive	5 A S.B.	1500 A	EIR01023	Littelfuse 0215005.HXP
	XL5e-20: Motor Bus Voltage Positive	10 A S.B.	1500 A	EIR01020	Littelfuse 0215010.HXP

(1) Short Circuit Current Rating
NOTE: F100 is located on the control board. F4, F5, F6, and F7 are located on the power supply board.

This page intentionally left blank.

Appendix A: Warranty and Field Service

Aerotech, Inc. warrants its products to be free from harmful defects caused by faulty materials or poor workmanship for a minimum period of one year from date of shipment from Aerotech. Aerotech's liability is limited to replacing, repairing or issuing credit, at its option, for any products that are returned by the original purchaser during the warranty period. Aerotech makes no warranty that its products are fit for the use or purpose to which they may be put by the buyer, whether or not such use or purpose has been disclosed to Aerotech in specifications or drawings previously or subsequently provided, or whether or not Aerotech's products are specifically designed and/or manufactured for buyer's use or purpose. Aerotech's liability on any claim for loss or damage arising out of the sale, resale, or use of any of its products shall in no event exceed the selling price of the unit.

THE EXPRESS WARRANTY SET FORTH HEREIN IS IN LIEU OF AND EXCLUDES ALL OTHER WARRANTIES, EXPRESSED OR IMPLIED, BY OPERATION OF LAW OR OTHERWISE. IN NO EVENT SHALL AEROTECH BE LIABLE FOR CONSEQUENTIAL OR SPECIAL DAMAGES.

Return Products Procedure

Claims for shipment damage (evident or concealed) must be filed with the carrier by the buyer. Aerotech must be notified within thirty (30) days of shipment of incorrect material. No product may be returned, whether in warranty or out of warranty, without first obtaining approval from Aerotech. No credit will be given nor repairs made for products returned without such approval. A "Return Materials Authorization (RMA)" number must accompany any returned product(s). The RMA number may be obtained by calling an Aerotech service center or by submitting the appropriate request available on our website (www.aerotech.com). Products must be returned, prepaid, to an Aerotech service center (no C.O.D. or Collect Freight accepted). The status of any product returned later than thirty (30) days after the issuance of a return authorization number will be subject to review.

Visit [Global Technical Support Portal](#) for the location of your nearest Aerotech Service center.

Returned Product Warranty Determination

After Aerotech's examination, warranty or out-of-warranty status will be determined. If upon Aerotech's examination a warranted defect exists, then the product(s) will be repaired at no charge and shipped, prepaid, back to the buyer. If the buyer desires an expedited method of return, the product(s) will be shipped collect. Warranty repairs do not extend the original warranty period.

Fixed Fee Repairs - Products having fixed-fee pricing will require a valid purchase order or credit card particulars before any service work can begin.

All Other Repairs - After Aerotech's evaluation, the buyer shall be notified of the repair cost. At such time the buyer must issue a valid purchase order to cover the cost of the repair and freight, or authorize the product(s) to be shipped back as is, at the buyer's expense. Failure to obtain a purchase order number or approval within thirty (30) days of notification will result in the product(s) being returned as is, at the buyer's expense.

Repair work is warranted for ninety (90) days from date of shipment. Replacement components are warranted for one year from date of shipment.

Rush Service

At times, the buyer may desire to expedite a repair. Regardless of warranty or out-of-warranty status, the buyer must issue a valid purchase order to cover the added rush service cost. Rush service is subject to Aerotech's approval.

On-site Warranty Repair

If an Aerotech product cannot be made functional by telephone assistance or by sending and having the customer install replacement parts, and cannot be returned to the Aerotech service center for repair, and if Aerotech determines the problem could be warranty-related, then the following policy applies:

Aerotech will provide an on-site Field Service Representative in a reasonable amount of time, provided that the customer issues a valid purchase order to Aerotech covering all transportation and subsistence costs. For warranty field repairs, the customer will not be charged for the cost of labor and material. If service is rendered at times other than normal work periods, then special rates apply.

If during the on-site repair it is determined the problem is not warranty related, then the terms and conditions stated in the following "On-Site Non-Warranty Repair" section apply.

On-site Non-Warranty Repair

If any Aerotech product cannot be made functional by telephone assistance or purchased replacement parts, and cannot be returned to the Aerotech service center for repair, then the following field service policy applies:

Aerotech will provide an on-site Field Service Representative in a reasonable amount of time, provided that the customer issues a valid purchase order to Aerotech covering all transportation and subsistence costs and the prevailing labor cost, including travel time, necessary to complete the repair.

Service Locations

<https://www.aerotech.com/contact-sales.aspx?mapState=showMap>

USA, CANADA, MEXICO

Aerotech, Inc.
Global Headquarters

CHINA

Aerotech China
Full-Service Subsidiary

GERMANY

Aerotech Germany
Full-Service Subsidiary

TAIWAN

Aerotech Taiwan
Full-Service Subsidiary

UNITED KINGDOM

Aerotech United Kingdom
Full-Service Subsidiary

Appendix B: Voltage Selection Operation



DANGER: Voltage selector settings must not be changed with Mains power applied to the unit.



DANGER: Wait at least ten (10) minutes after removing the power supply before performing maintenance or an inspection. Otherwise, there is the danger of electric shock.



WARNING: The voltage selector must be configured to match the AC line voltage on the Motor Supply Connector and is factory-configured based on the options that you ordered. You could damage the unit if the voltage selector is set for the incorrect AC input voltage.

If the user changes the voltage selector settings, it is also the user's responsibility to change the iXL5e/XL5e AC power label located next to the Motor Supply connector. Refer to the [Section 1.4](#) for power ratings.

Procedure for setting AC voltage selector switches:

1. Turn-off and disconnect all power from unit.
2. Set the S1 and S2 switches for your voltage on the Motor Supply Connector.
NOTE: Refer to [Figure B-1](#) to see how switch position relates to voltage selection.
3. Apply a visible indicator on the drive that lets the user know that the voltage input configuration has changed and that the factory order part number no longer represents the current configuration.

Figure B-1: Voltage Selection Switch Access

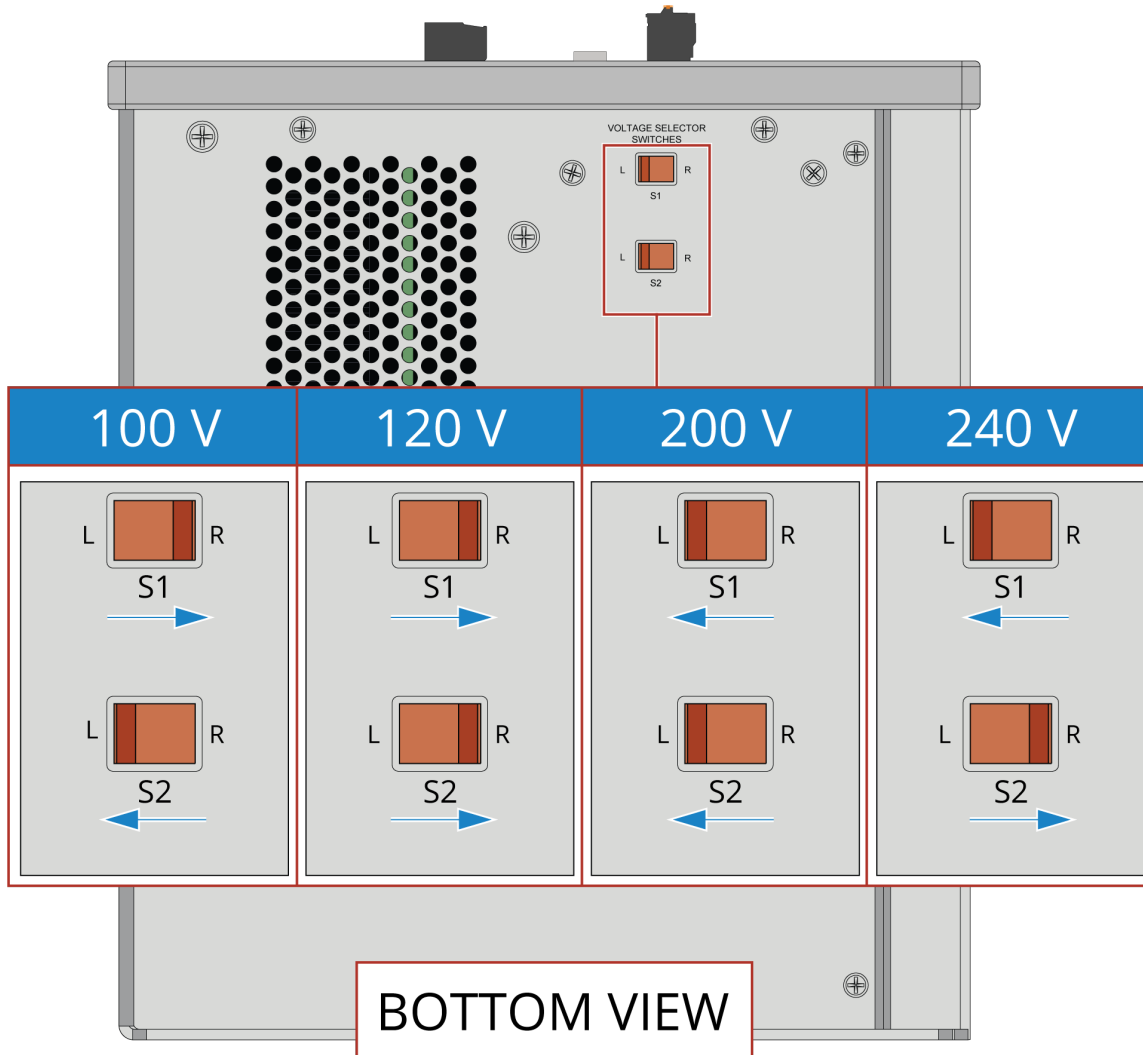

Appendix C: Revision History

Revision	Description
1.14	Section updated: Appendix B: Voltage Selection Operation
1.13	Updated: <ul style="list-style-type: none"> • Agency Approvals (Agency Approvals) • Feature Summary (Section 1.1.) • Table 5-1 (red power description)
1.12	Updated: Section 2.4. Safe Torque Off Input (STO)
1.11	General updates
1.10	Revision changes have been archived. If you need a copy of this revision, contact AerotechGlobal Technical Support.
1.09	
1.08	
1.07	
1.06	
1.05	
1.04	
1.03	
1.02	
1.01	
1.00	

This page intentionally left blank.

Index

-		
-EB1		
Analog Inputs	92	Analog Input Pins (Aux I/O Connector) 74
Analog Outputs	91	Analog Input Typical Connection [-EB1] 92
Digital Inputs	88	Analog Inputs [-EB1] 92
Digital Outputs	84	Analog Output 0 on the Aux I/O Connector 73
I/O Option Board	83	Analog Output 0 Schematic (Aux I/O Connector) 73
Position Synchronized Output (PSO) Interface	93	Analog Output 0 Specifications (Aux I/O Connector) 73
-MX2	43	Analog Output Connector [-EB1] Mating Connector Part Numbers 91
-MX3	43,63	Analog Output Connector Pinout [-EB1] 91
		Analog Output Pins (Aux I/O Connector) 73
		Analog Output Specifications [-EB1] 91
		Analog Output Typical Connection [-EB1] 91
		Analog Outputs [-EB1] 91
		Aux Connector
		Analog Encoder 63
		Sine Wave Encoder 63
		Aux I/O Connector
		Analog Input 0 74
		Analog Output 0 73
		Auxiliary Encoder Interface 60
		Digital Outputs 67
		High-Speed User Inputs 72
		Position Synchronized Output 65
		PSO 65
		Aux I/O Connector Mating Connector Part Numbers 59
		Auxiliary Encoder (Aux I/O Connector) 60
		Auxiliary I/O Connector
		Absolute Encoder 62
		Analog Encoder 43
		RS-422 Line Driver Encoder 61
		Sine Wave Encoder 43
		Square Wave Encoder 61
		Auxiliary I/O Connector Pinout 59
		Auxiliary I/O Pins (Aux I/O Connector) 60
		B
		BiSS absolute encoder 42,62
		Brake Connected to the Feedback Connector 52
		Brake Control Relay Specifications 52
		Brake Output Connector Pinout 75
		Brake Output Pins on the Feedback Connector 52
		Brake Outputs (Feedback Connector) 52
		Brake Power Supply Connector 75
		Brake Power Supply Connector Mating Connector Part Numbers 75
2		
2006/42/EC	9	
2014/30/EU	9	
2014/35/EU	9,11	
		A
Absolute Encoder		
BiSS	42,62	
EnDat	42,62	
SSI	42,62	
Absolute Encoder (Auxiliary I/O Connector)	62	
Absolute Encoder (Feedback Connector)	42	
Absolute Encoder Schematic (Auxiliary I/O Connector)	62	
Absolute Encoder Schematic (Feedback Connector)	42	
Absolute Encoder Specifications (Auxiliary I/O Connector)	62	
Absolute Encoder Specifications (Feedback Connector)	42	
Agency Approvals	11	
Altitude	27	
Analog Encoder (Aux Connector)	63	
Analog Encoder (Auxiliary I/O Connector)	43	
Analog Encoder Phasing Reference Diagram	63	
Analog Encoder Schematic (Auxiliary I/O Connector)	64	
Analog Encoder Specifications (Auxiliary I/O Connector)	63	
Analog Encoder Specifications (Feedback Connector)	43	
Analog Input 0 on the Aux I/O Connector	74	
Analog Input 0 Schematic (Aux I/O Connector)	74	
Analog Input 0 Specifications (Aux I/O Connector)	74	
Analog Input Connector [-EB1] Mating Connector Part Numbers	92	
Analog Input Connector Pinout [-EB1]	92	

Encoder and Hall Signal Diagnostics	33	Absolute Encoder Schematic (Auxiliary I/O Connector)	62
Encoder Fault Input (Feedback Connector)	48	Absolute Encoder Schematic (Feedback Connector)	42
Encoder Fault Input Pin on the Feedback Connector	48	Analog Encoder Schematic (Auxiliary I/O Connector)	64
Encoder Phasing	45	Analog Input 0 Schematic (Aux I/O Connector)	74
Encoder Phasing Reference Diagram	45	Analog Input Typical Connection [-EB1]	92
Encoder Pins on the Feedback Connector	40	Analog Output 0 Schematic (Aux I/O Connector)	73
End of Travel Limit Input (Feedback Connector)	49	Analog Output Typical Connection [-EB1]	91
End of Travel Limit Input Connections	50	Brake Connected to the Feedback Connector	52
End of Travel Limit Input Diagnostic Display	51	Brushless Motor Configuration (Motor Power Output Connector)	32
End of Travel Limit Input Pins on the Feedback Connector	49	Control Supply Connections	29
End of Travel Limit Phasing	51	DC Brush Motor Configuration (Motor Power Output Connector)	35
EnDat absolute encoder	42,62	Digital Inputs Connected to a Current Sinking Device [-EB1]	90
Environmental Specifications	27	Digital Inputs Connected to a Current Sourcing Device [-EB1]	90
EU 2015/863	9	Digital Inputs Connected to Current Sinking Devices (Aux I/O Connector)	71
examining parts		Digital Inputs Connected to Current Sourcing Devices (Aux I/O Connector)	71
cables	100	Digital Output Schematic (Aux I/O Connector)	68
connections	100	Digital Outputs Connected in Current Sinking Mode (Aux I/O Connector)	69
examining, dangerous fluids	100	Digital Outputs Connected in Current Sourcing Mode (Aux I/O Connector)	69
examining, dangerous material	100	Digital Outputs Schematic [-EB1]	86
		Dimensions (without -EB1)	25
		Dimensions with -EB1	26
		End of Travel Limit Input Connections	50
		End of Travel Limit Input Diagnostic Display	51
		Hall-Effect Inputs Schematic	46
		High-Speed Inputs	72
		Home Limit Input Connections	50
		Home Limit Input Diagnostic Display	51
		Isolated Output Current Sinks Schematic (PSO)	94
		Isolated Output Current Sources Schematic (PSO)	94
		Motor Supply Connections	30
		Outputs Connected in Current Sinking Mode [-IO]	87
		Outputs Connected in Current Sourcing Mode [-EB1]	87
		Positive Motor Direction	33
		PSO Isolated Output Sinks Current	94
		PSO Isolated Output Sources Current	94
		PSO TTL Outputs Schematic	94
		Sine Wave Encoder Schematic (Auxiliary I/O Connector)	64
		Square Wave Encoder Inputs Schematic (Aux I/O Connector)	61
F			
F100	101		
F4	101		
F5	101		
F6	101		
F7	101		
Feature Summary	20		
Feedback Connector	39		
Absolute Encoder	42		
Brake Outputs	52		
Encoder	40		
Encoder Fault Input	48		
End of Travel Limit Input	49		
Hall-Effect Inputs	46		
Home Limit Input	49		
Pinout	39		
Primary Encoder	40		
RS-422 Line Driver Encoder	41		
Square Wave Encoder	41		
Thermistor Input	47		
Travel Limit Input	49		
Feedback Monitoring	33		
Figure			
-EB1 I/O Option Board Connectors	83		

Square Wave Encoder Schematic (Feedback Connector)	41	Introduction	17
Stepper Motor Configuration	37	IP20 Drive IP Rating	24
STO Timing	58	IP54 Compliant Enclosure	24
Thermistor Input Schematic	47	Isolated Output Current Sinks Schematic (PSO)	94
Three Phase Stepper Motor Configuration	38	Isolated Output Current Sources Schematic (PSO)	94
TTL Outputs Schematic (PSO)	94		
Typical STO Configuration	54	J	
fluids, dangerous	100	Joystick Interface	96
Functional Diagram	21		
Fuse Specifications	101	L	
Control Supply at L	101	Laser Firing	65
External Shunt (-SX1)	101		
Motor Supply at AC1	101	M	
		Maintenance	99
H		material, electrically conductive	100
Hall-Effect Feedback Pins on the Feedback Connector	46	Mating Connector	
Hall-Effect Inputs (Feedback Connector)	46	Analog Output Connector [-EB1]	91
Hall-Effect Inputs Schematic	46	Mating Connector P/N	
Handling	14	Analog Input Connector [-EB1]	92
Handwheel Interconnection (to Aux I/O through a BBA32 Module)	98	Aux I/O Connector	59
Handwheel Interconnection to the Aux I/O Connector	98	Brake Power Supply Connector	75
Handwheel Interface	98	Control Supply Connector	29
High-Speed Input Pins on the Aux I/O Connector	72	Digital Input 2 Connector [-EB1]	89
High-Speed Input Specifications	72	Digital Output 1 Connector [-EB1]	85
High-Speed Inputs	72	Digital Output 2 Connector [-EB1]	85
High-Speed User Inputs (Aux I/O Connector)	72	Feedback Connector	39
Home Limit Input (Feedback Connector)	49	Motor Power Output Connector	31
Home Limit Input Connections	50	Motor Supply Connector	30
Home Limit Input Diagnostic Display	51	PSO Connector [-EB1]	93
Home Limit Input Pins on the Feedback Connector	49	STO Connector	53
Humidity	27	Mechanical Specifications	24
HyperWire	76	Motor Connector	
Cable Part Numbers	76	Mating Connector Part Numbers	39
Card Part Number	76	Motor Function Relative to STO Input State	57
		Motor Power Output Connector	31
I		Brushless Motor Connections	32
I/O Option Board [-EB1]	83	DC Brush Motor Connections	35
Input Power Connections	29	Mating Connector Part Numbers	31
inspecting cooling vents	100	Pinout	31
Inspection	100	Stepper Motor Connections	37
Installation and Configuration	29	Three Phase Stepper Motor Connections	38
Installation Connection Overview	15-16	Motor Supply Connections	30
Installation Overview	15		

Sine Wave Encoder (Auxiliary I/O Connector)	43	External Delay Timer	56
Sine Wave Encoder Phasing Reference Diagram	63	Functional Description	56
Sine Wave Encoder Schematic (Auxiliary I/O Connector)	64	Mating Connector Part Numbers	53
Sine Wave Encoder Specifications (Auxiliary I/O Connector)	63	Motor Function Relative to the STO Input State	57
Sine Wave Encoder Specifications (Feedback Connector)	43	Signal Delay	57
Specifications		Standards	55
Absolute Encoder (Auxiliary I/O Connector)	62	Standards Data	55
Absolute Encoder (Feedback Connector)	42	Startup Validation Testing	57
Analog Encoder (Auxiliary I/O Connector)	63	Timing	58
Analog Encoder (Feedback Connector)	43	Typical Configuration	54
Analog Input 0 (Aux I/O Connector)	74	Storage	14
Analog Output 0 (Aux I/O Connector)	73	Sync-Related Commands	77
Analog Outputs [-EB1]	91	Sync Port	
Brake Control Relay	52	PSO Tracking	77
Control Board Fuses	101	Sync Port Cables	77
Differential Analog Inputs [-EB1]	92	Sync Ports	77
Digital Inputs (Aux I/O Connector)	70	System part number	14
Digital Inputs [-EB1]	88	System Power Requirements	23
Digital Outputs (Aux I/O Connector)	67		
Digital Outputs [-EB1]	84	T	
High-Speed Inputs	72	Table of Contents	3
Motor Supply Connector Wiring	30	Temperature	27
Power Supply Board Fuses	101	Thermistor Input (Feedback Connector)	47
PSO (Aux I/O Connector)	65	Thermistor Input Pin on the Feedback Connector	47
PSO [-EB1]	93	Thermistor Input Schematic	47
RS-422 Encoder (Feedback Connector)	41,61	Three Phase Stepper Motor Configuration	38
Sine Wave Encoder (Auxiliary I/O Connector)	63	Three Phase Stepper Motor Connections (Motor Power Output Connector)	38
Sine Wave Encoder (Feedback Connector)	43	Travel Limit Input (Feedback Connector)	49
Square Wave Encoder (Feedback Connector)	41,61	TTL Outputs Schematic (PSO)	94
STO Electrical Specifications	54	Two Axis Joystick Interface	96
Unit Weight	24	Two Axis Joystick Interface (to the I/O board of two drives)	97
Square Wave Encoder	41	Typical STO Configuration	54
Square Wave Encoder (Auxiliary I/O Connector)	61		
Square Wave Encoder Inputs Schematic (Aux I/O Connector)	61	U	
Square Wave Encoder Schematic (Feedback Connector)	41	Unit Weight	24
Square Wave Encoder Specifications (Feedback Connector)	41,61	Use	27
SSI absolute encoder	42,62		
Stepper Motor Configuration	37	V	
Stepper Motor Connections (Motor Power Output Connector)	37	Voltage Selection	105
Stepper Motor Phasing	37-38	Voltage Selection Switch	106
STO	53		
Connector Pinout	53		
Diagnostics	58		
Electrical Specifications	54		

W

Warranty and Field Service	103
Wire Colors for Aerotech-Supplied Brushless Motor Cables	32
Wire Colors for Aerotech-Supplied DC Brush Motor Cables	35
Wire Colors for Aerotech-Supplied Stepper Motor Cables	37

This page intentionally left blank.