

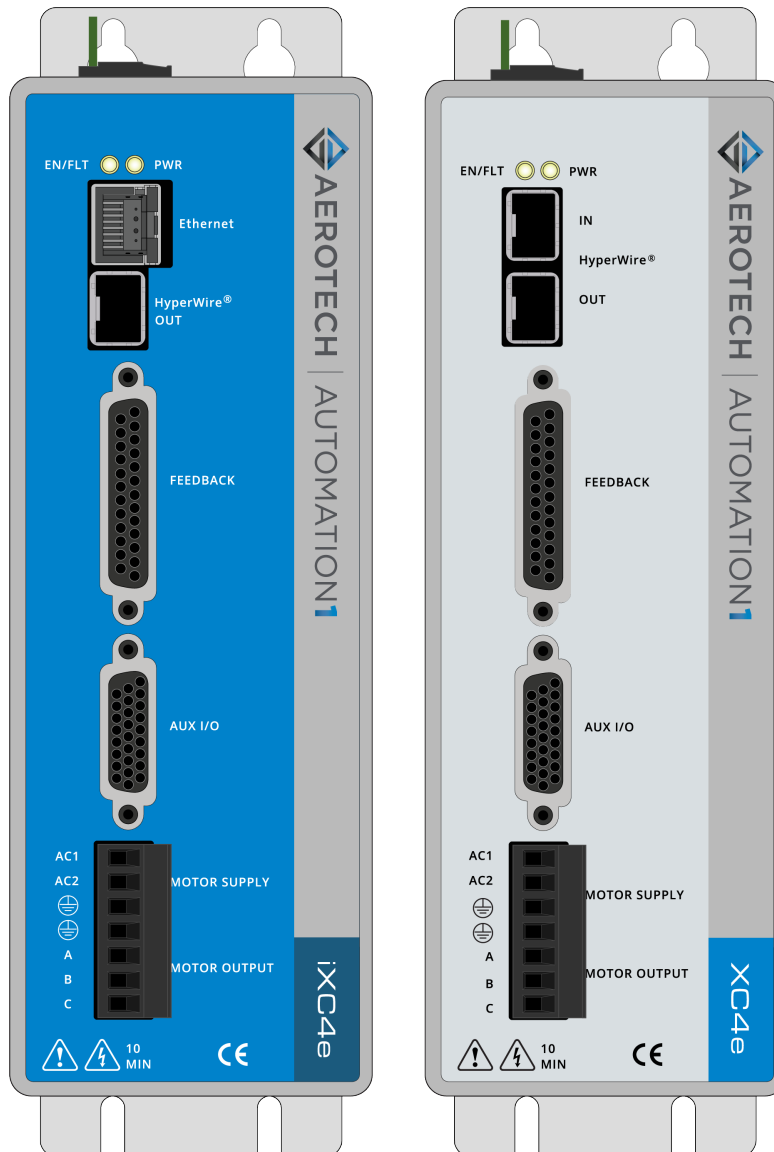

Automation1 iXC4e and XC4e PWM High-Performance Digital Drives

HARDWARE MANUAL

Revision 2.15



GLOBAL TECHNICAL SUPPORT

Go to the [Global Technical Support Portal](#) for information and support about your Aerotech, Inc. products. The website supplies software, product manuals, Help files, training schedules, and PC-to-PC remote technical support. If necessary, you can complete Product Return (RMA) forms and get information about repairs and spare or replacement parts. To get help immediately, contact a service office or your sales representative. Include your customer order number in your email or have it available before you call.

This manual contains proprietary information and may not be reproduced, disclosed, or used in whole or in part without the express written permission of Aerotech, Inc. Product names mentioned herein are used for identification purposes only and may be trademarks of their respective companies.

Copyright © 2018-2024, Aerotech, Inc., All rights reserved.



Table of Contents

Automation1 iXC4e and XC4e PWM High-Performance Digital Drives	1
Table of Contents	3
List of Figures	5
List of Tables	7
EU Declaration of Conformity	9
UKCA Declaration of Conformity	10
Korean Certification	11
Agency Approvals	12
Safety Procedures and Warnings	13
Handling and Storage	15
Installation Overview	16
Chapter 1: iXC4e/XC4e Overview	19
1.1. Feature Summary	21
1.2. Ordering Options	22
1.3. Functional Block Diagram	23
1.4. Electrical Specifications	24
1.4.1. System Power Requirements	25
1.4.2. Real-Time Clock Requirements (iXC4e Only)	25
1.5. Mechanical Specifications	26
1.5.1. Mounting and Cooling	26
1.5.2. Dimensions	27
1.6. Environmental Specifications	29
1.7. Drive and Software Compatibility	29
Chapter 2: Installation and Configuration	31
2.1. Input Power Connections	31
2.1.1. Control Supply Connector	31
2.1.2. Motor Supply Connector	32
2.1.3. Transformer Options	33
2.1.4. Minimizing Noise for EMC/CE Compliance	40
2.2. Motor Power Output Connector	41
2.2.1. Brushless Motor Connections	42
2.2.1.1. Brushless Motor Powered Motor and Feedback Phasing	43
2.2.1.2. Brushless Motor Unpowered Motor and Feedback Phasing	44
2.2.2. DC Brush Motor Connections	45
2.2.2.1. DC Brush Motor Phasing	45
2.2.3. Stepper Motor Connections	46
2.2.3.1. Stepper Motor Phasing	46
2.2.4. Three Phase Stepper Motor Connections	47
2.2.4.1. Stepper Motor Phasing	47
2.3. Feedback Connector	48
2.3.1. Primary Encoder Inputs	49
2.3.1.1. Square Wave Encoder (Primary)	50
2.3.1.2. Absolute Encoder (Primary)	51
2.3.1.3. Sine Wave Encoder (Primary) [-MX2/-MX3 Option]	52
2.3.1.4. Encoder Phasing	54
2.3.2. Hall-Effect Inputs	55
2.3.3. Thermistor Input	56
2.3.4. Encoder Fault Input	57
2.3.5. End of Travel and Home Limit Inputs	58
2.3.5.1. End of Travel and Home Limit Phasing	60
2.3.6. Brake Outputs	61
2.4. Safe Torque Off Input (STO)	62
2.4.1. STO Standards	64
2.4.2. STO Functional Description	65
2.4.3. STO Startup Validation Testing	66
2.4.4. STO Diagnostics	67
2.5. Auxiliary I/O Connector	68

2.5.1. Auxiliary Encoder Interface	69
2.5.1.1. Square Wave Encoder (Auxiliary)	70
2.5.1.2. Absolute Encoder (Auxiliary)	71
2.5.1.3. Sine Wave Encoder (Auxiliary) [-MX3 Option]	72
2.5.2. Position Synchronized Output (PSO)	74
2.5.3. Digital Outputs	76
2.5.4. Digital Inputs	79
2.5.5. High-Speed Inputs	81
2.5.6. Analog Output 0	82
2.5.7. Analog Input 0 (Differential)	83
2.6. Brake Power Supply Connector	84
2.7. HyperWire Interface	85
2.8. External Shunt Option [-SX1]	86
2.9. Sync Port	88
2.10. Industrial Ethernet (iXC4e Only)	88
2.11. System Interconnection	89
2.12. PC Configuration and Operation Information	92
Chapter 3: -EB1 Option Expansion Board	93
3.1. Digital Outputs [-EB1]	94
3.2. Digital Inputs [-EB1]	98
3.3. Analog Outputs [-EB1]	101
3.4. Analog Inputs [-EB1]	102
3.5. PSO Interface [-EB1]	103
Chapter 4: Cables and Accessories	105
4.1. Joystick Interface	106
4.2. Handwheel Interface	108
Chapter 5: Maintenance	109
5.1. Preventative Maintenance	110
5.2. Fuse Specifications	111
Appendix A: Warranty and Field Service	113
Appendix B: Revision History	115
Index	117

List of Figures

Figure 1-1:	iXC4e Digital Drive-Based Controller	19
Figure 1-2:	XC4e Digital Drive	20
Figure 1-3:	Functional Diagram	23
Figure 1-4:	Dimensions	27
Figure 1-5:	Dimensions [-EB1]	28
Figure 2-1:	Control Supply Connections	31
Figure 2-2:	Motor Supply Connections	32
Figure 2-3:	TV0.3-28-56-ST Transformer Control and Motor Power Wiring (40 VDC Bus)	34
Figure 2-4:	TV0.3-28-56-ST Transformer Control and Motor Power Wiring (80 VDC Bus)	35
Figure 2-5:	TV0.3-28-56-ST Transformer Control and Motor Power Wiring (160 VDC Bus)	36
Figure 2-6:	TV0.3-28 Transformer Control and Motor Power Wiring (40 VDC Bus)	37
Figure 2-7:	TV0.3-56 Transformer Control and Motor Power Wiring (80 VDC Bus)	38
Figure 2-8:	TM3/TM5 Transformer Control and Motor Power Wiring	39
Figure 2-9:	Brushless Motor Configuration	42
Figure 2-10:	Positive Motor Direction	43
Figure 2-11:	Encoder and Hall Signal Diagnostics	43
Figure 2-12:	Brushless Motor Phasing Oscilloscope Example	44
Figure 2-13:	Brushless Motor Phasing Goal	44
Figure 2-14:	DC Brush Motor Configuration	45
Figure 2-15:	Positive Motor Direction	45
Figure 2-16:	Stepper Motor Configuration	46
Figure 2-17:	Positive Motor Direction	46
Figure 2-18:	Three Phase Stepper Motor Configuration	47
Figure 2-19:	Positive Motor Direction	47
Figure 2-20:	Square Wave Encoder Schematic (Feedback Connector)	50
Figure 2-21:	Absolute Encoder Schematic (Feedback Connector)	51
Figure 2-22:	Sine Wave Encoder Phasing Reference Diagram	52
Figure 2-23:	Sine Wave Encoder Schematic (Feedback Connector)	53
Figure 2-24:	Encoder Phasing Reference Diagram (Standard)	54
Figure 2-25:	Position Feedback in the Diagnostic Display	54
Figure 2-26:	Hall-Effect Inputs Schematic (Feedback Connector)	55
Figure 2-27:	Thermistor Input Schematic (Feedback Connector)	56
Figure 2-28:	Encoder Fault Input Schematic (Feedback Connector)	57
Figure 2-29:	End of Travel and Home Limit Input Connections	59
Figure 2-30:	End of Travel and Home Limit Input Schematic (Feedback Connector)	59
Figure 2-31:	End of Travel and Home Limit Input Diagnostic Display	60
Figure 2-32:	Brake Connected to the 25-Pin Feedback Connector (Typical)	61
Figure 2-33:	Typical STO Configuration	63
Figure 2-34:	STO Timing	67
Figure 2-35:	Square Wave Encoder Interface (Aux I/O Connector)	70
Figure 2-36:	Absolute Encoder Schematic (Auxiliary I/O Connector)	71
Figure 2-37:	Sine Wave Encoder Phasing Reference Diagram	72
Figure 2-38:	Sine Wave Encoder Schematic (Auxiliary I/O Connector)	73
Figure 2-39:	PSO Interface	75
Figure 2-40:	Digital Output Schematic (Aux I/O Connector)	77
Figure 2-41:	Digital Outputs Connected in Current Sourcing Mode	78
Figure 2-42:	Digital Outputs Connected in Current Sinking Mode	78
Figure 2-43:	Digital Inputs Schematic (Aux I/O Connector)	79

Figure 2-44: Digital Inputs Connected to Current Sourcing Devices	80
Figure 2-45: Digital Inputs Connected to Current Sinking Devices	80
Figure 2-46: High-Speed Inputs	81
Figure 2-47: Analog Output 0 Schematic	82
Figure 2-48: Analog Input 0 Schematic	83
Figure 2-49: Drive-Based System Wiring Drawing (Best Practice)	89
Figure 2-50: PC-Based System Wiring Drawing (Best Practice)	89
Figure 2-51: Recommended System Connections for a Drive-Based Controller	90
Figure 2-52: Recommended System Connections for a PC-Based Controller	91
Figure 3-1: -EB1 I/O Option Board Connectors (iXC4e shown)	93
Figure 3-2: Digital Outputs Schematic [-EB1]	96
Figure 3-3: Digital Outputs Connected in Current Sourcing Mode [-EB1]	97
Figure 3-4: Digital Outputs Connected in Current Sinking Mode [-EB1]	97
Figure 3-5: Digital Inputs Schematic [-EB1]	99
Figure 3-6: Digital Inputs Connected to Current Sourcing (PNP) Devices [-EB1]	100
Figure 3-7: Digital Inputs Connected to Current Sinking (NPN) Devices [-EB1]	100
Figure 3-8: Analog Output Typical Connection [-EB1]	101
Figure 3-9: Analog Input Typical Connection [-EB1]	102
Figure 3-10: PSO Output Sources Current	104
Figure 3-11: PSO Output Sinks Current	104
Figure 3-12: PSO TTL Outputs Schematic	104
Figure 4-1: Two Axis Joystick Interface (to the Aux I/O of two drives)	106
Figure 4-2: Two Axis Joystick Interface (to the I/O board)	107
Figure 4-3: Handwheel Interconnection to Aux I/O Connector	108
Figure 4-4: Handwheel Interconnection to the Aux I/O through a BBA32 Module	108
Figure 5-1: Fuse Locations on the iXC4e Control Board	111

List of Tables

Table 1-1: Example Order and Ordering Options	22
Table 1-2: Electrical Specifications (Common)	24
Table 1-3: Electrical Specifications (by Ordering Option)	24
Table 1-4: Mounting Specifications	26
Table 1-5: Environmental Specifications	29
Table 1-6: Drive and Software Compatibility	29
Table 2-1: Control Supply Connector Pinout	31
Table 2-2: Control Supply Mating Connector Ratings	31
Table 2-3: Motor Supply Connector Pinout	32
Table 2-4: Motor Supply Mating Connector Ratings	32
Table 2-5: Nominal Motor Operating Voltages / Required AC Voltages	33
Table 2-6: Transformer Options	33
Table 2-7: Motor Power Output Connector Pinout	41
Table 2-8: Motor Power Output Mating Connector Ratings	41
Table 2-9: Wire Colors for Aerotech-Supplied Brushless Motor Cables	42
Table 2-10: Hall Signal Diagnostics	43
Table 2-11: Wire Colors for Aerotech-Supplied DC Brush Motor Cables	45
Table 2-12: Wire Colors for Aerotech-Supplied Stepper Motor Cables	46
Table 2-13: Feedback Connector Pinout	48
Table 2-14: Feedback Mating Connector Ratings	48
Table 2-15: Multiplier Options	49
Table 2-16: Primary Encoder Pins on the Feedback Connector	49
Table 2-17: Square Wave Encoder Specifications	50
Table 2-18: Absolute Encoder Specifications	51
Table 2-19: Sine Wave Encoder Specifications	52
Table 2-20: Hall-Effect Feedback Pins on the Feedback Connector	55
Table 2-21: Thermistor Input Pin on the Feedback Connector	56
Table 2-22: Encoder Fault Input Pin on the Feedback Connector	57
Table 2-23: End of Travel and Home Limit Pins on the Feedback Connector	58
Table 2-24: Brake Output Pins on the Feedback Connector	61
Table 2-25: Brake Control Specifications	61
Table 2-26: STO Connector Pinout	62
Table 2-27: STO Mating Connector Ratings	62
Table 2-28: STO Electrical Specifications	63
Table 2-29: STO Standards	64
Table 2-30: STO Standards Data	64
Table 2-31: STO Signal Delay	66
Table 2-32: Motor Function Relative to STO Input State	66
Table 2-33: STO Timing	67
Table 2-34: Auxiliary I/O Connector Pinout	68
Table 2-35: Auxiliary I/O Mating Connector Ratings	68
Table 2-36: Auxiliary Encoder Pins on the Auxiliary I/O Connector	69
Table 2-37: Square Wave Encoder Specifications	70
Table 2-38: Absolute Encoder Specifications	71
Table 2-39: Sine Wave Encoder Specifications	72
Table 2-40: PSO Specifications	74
Table 2-41: PSO Pins on the Auxiliary I/O Connector	74
Table 2-42: Digital Output Specifications	76

Table 2-43:	Digital Output Pins on the Auxiliary I/O Connector	76
Table 2-44:	Digital Input Specifications	79
Table 2-45:	Digital Input Pins on the Auxiliary I/O Connector	79
Table 2-46:	High-Speed Input Specifications	81
Table 2-47:	High-Speed Input Pins on the Auxiliary I/O Connector	81
Table 2-48:	Analog Output Specifications	82
Table 2-49:	Analog Output Pins on the Auxiliary I/O Connector	82
Table 2-50:	Analog Input Specifications	83
Table 2-51:	Analog Input Pins on the Auxiliary I/O Connector	83
Table 2-52:	Brake Power Supply Connector Pinout	84
Table 2-53:	Brake Power Supply Mating Connector Ratings	84
Table 2-54:	HyperWire Card Part Number	85
Table 2-55:	HyperWire Cable Part Numbers	85
Table 2-56:	-SX1 Component Information	86
Table 2-57:	Maximum Additional Storage Energy for a Standard iXC4e/XC4e	87
Table 2-58:	Sync-Related Functions	88
Table 2-59:	Sync Port Cables	88
Table 3-1:	Digital Output Specifications [-EB1]	94
Table 3-2:	Digital Output 1 Connector Pinout [-EB1]	95
Table 3-3:	Digital Output 2 Connector Pinout [-EB1]	95
Table 3-4:	Digital Output 1 and 2 Mating Connector Ratings [-EB1]	95
Table 3-5:	Digital Input Specifications [-EB1]	98
Table 3-6:	Digital Input 1 Connector Pinout [-EB1]	98
Table 3-7:	Digital Input 2 Connector Pinout [-EB1]	99
Table 3-8:	Digital Input 1 and 2 Mating Connector Ratings [-EB1]	99
Table 3-9:	Analog Output Specifications [-EB1]	101
Table 3-10:	Analog Output Connector Pinout [-EB1]	101
Table 3-11:	Analog Output Mating Connector Ratings [-EB1]	101
Table 3-12:	Differential Analog Input Specifications [-EB1]	102
Table 3-13:	Analog Input Connector Pinout [-EB1]	102
Table 3-14:	Analog Input Mating Connector Ratings [-EB1]	102
Table 3-15:	PSO Specifications [-EB1]	103
Table 3-16:	PSO Interface Connector Pinout [-EB1]	103
Table 3-17:	PSO Interface Mating Connector Ratings [-EB1]	103
Table 4-1:	Standard Interconnection Cables	105
Table 5-1:	LED Description	109
Table 5-2:	Troubleshooting	109
Table 5-3:	Preventative Maintenance	110
Table 5-4:	Control Board Fuse Specifications	111

EU Declaration of Conformity

Manufacturer Aerotech, Inc.
Address 101 Zeta Drive
 Pittsburgh, PA 15238-2811
 USA
Product iXC4e/XC4e
Model/Types All



This is to certify that the aforementioned product is in accordance with the applicable requirements of the following directive(s):

2014/30/EU	Electromagnetic Compatibility (EMC)
2014/35/EU	Low Voltage Directive
2006/42/EC	Machinery Directive
EU 2015/863	Directive, Restricted Substances (RoHS 3)

and has been designed to be in conformity with the applicable requirements of the following standard(s) when installed and used in accordance with the manufacturer's supplied installation instructions.

EN 61010-1:2010/AMD1:2016	Safety Requirements for Electrical Equipment
EN 61800-3:2004/A1:2011	EMC Requirements for Power Drives
IEC 61800-5-1:2016	Electrical Safety for Power Drive Systems
IEC 61800-5-2:2016	Functional Safety for Power Drive Systems
EN 55011:2000/A2:2003	Conducted and Radiated Emissions
EN 55022:1998	Conducted and Radiated Emissions

Authorized Representative:

/ Jochen Jäger

Operations Manager
 Aerotech GmbH
 Gustav-Weißkopf-Str. 18
 90768 Fürth
 Germany

Engineer Verifying Compliance

/ Alex Weibel

Aerotech, Inc.
 101 Zeta Drive
 Pittsburgh, PA 15238-2811
 USA
 8/15/2024

Date

UKCA Declaration of Conformity

Manufacturer Aerotech, Inc.
Address 101 Zeta Drive
 Pittsburgh, PA 15238-2811
 USA
Product iXC4e/XC4e
Model/Types All



To which this declaration relates, meets the essential health and safety requirements and is in conformity with the relevant UK Legislation listed below:

Electrical Equipment (Safety) Regulations 2016
 Electromagnetic Compatibility Regulations 2016
 Supply of Machinery (Safety) Regulations 2008
 Hazardous Substances in Electrical and Electronic Equipment Regulations 2012

Using the relevant section of the following UK Designated Standards and other normative documents when installed in accordance with the installation instructions supplied by the manufacturer.

EN 61010-1:2010/AMD1:2016	Safety Requirements for Electrical Equipment
EN 61800-3:2004/A1:2011	EMC Requirements for Power Drives
IEC 61800-5-1:2016	Electrical Safety for Power Drive Systems
IEC 61800-5-2:2016	Functional Safety for Power Drive Systems
EN 55011:2000/A2:2003	Conducted and Radiated Emissions
EN 55022:1998	Conducted and Radiated Emissions

Authorized Representative:

/ Simon Smith

Managing Director
 Aerotech Ltd
 The Old Brick Kiln, Ramsdell, Tadley
 Hampshire RG26 5PR
 UK

Engineer Verifying Compliance

/ Alex Weibel

Aerotech, Inc.
 101 Zeta Drive
 Pittsburgh, PA 15238-2811
 USA
 8/15/2024

Date

Korean Certification**Registration of Broadcasting and Communication Equipments**

It is verified that the foregoing equipment has been registered under the Clause 3, Article 58-2 of the radio Waves Act.

Agency Approvals

The iXC4e/XC4e drives have been tested by the following NRTL(s) and have been certified to the standards that follow:

Approval: CUS NRTL
Approving Agency: TÜV SÜD America Inc.
Certificate #: U10 068995 0033
Standards: CSA C22.2 No. 61010-1:2012/A1:2018-11,
 UL 61010-1:2012/R2019-07



Certificate #: N8AUS 068995 0032
Standards: CE Attestation of Conformity,
 Low Voltage Directive 2014/35/EU,
 EN 61010-1:2010/AMD1:2019

Approval: Safety Components (STO)
Approving Agency: TÜV SÜD
Certificate #: Z10 068995 0030 Rev. 01
Standards: IEC 61508-1:2010 (up to SIL3),
 IEC 61508-2:2010 (up to SIL3),
 ISO 13849-1:2023 (up to PL e),
 IEC 62061:2021 (maximum SIL 3)



Visit <https://www.tuev-sued.de/product-testing/certificates> to view Aerotech's TÜV SÜD certificates. Type the certificate number listed above in the search bar or type "Aerotech" for a list of all Aerotech certificates.

Approving Agency: UL
Product Identity: Industrial Control Equipment
File #: E529537
Standards: UL 61800-5-1



Safety Procedures and Warnings



IMPORTANT: This manual tells you how to carefully and correctly use and operate the drive.

- Read all parts of this manual before you install or operate the drive or before you do maintenance to your system.
- To prevent injury to you and damage to the equipment, obey the precautions in this manual.
- All specifications and illustrations are for reference only and were complete and accurate as of the release of this manual. To find the newest information about this product, refer to www.aerotech.com.

If you do not understand the information in this manual, contact Aerotech Global Technical Support.



IMPORTANT: This product has been designed for light industrial manufacturing or laboratory environments. If the product is used in a manner not specified by the manufacturer:

- The protection provided by the equipment could be impaired.
- The life expectancy of the product could be decreased.

Safety notes and symbols are placed throughout this manual to warn you of the potential risks at the moment of the safety note or if you fail to obey the safety note.



The voltage can cause shock, burn, or death.



You are at risk of physical injury.
You could damage the drive.



A surface can be hot enough to burn you.



Your actions, the temperature of the system, or the condition of the atmosphere that surround the system could start a fire.



Components are sensitive to electrostatic discharge.



Unsecured cables could cause you to:

- trip and fall
- drag the product off of its mounting location
- damage the cable connections.



A blue circle symbol is an action or tip that you should obey. Some examples include:

- General tip
- Read the manual/section
- Wear protective safety equipment (eye protection, ear protection, gloves)
- If applicable, do not lift unassisted



DANGER: To decrease the risk of electrical shock, injury, death, and damage to the equipment, obey the precautions that follow.



1. Before you do maintenance to the equipment, disconnect the electrical power.
2. Restrict access to the drive when it is connected to a power source.
3. Do not connect or disconnect electrical components, wires, and cables while this product is connected to a power source.
4. Wait at least ten (10) minutes after removing the power supply before doing maintenance or an inspection. Otherwise, there is the danger of electric shock.
5. Supply each operator with the necessary protection from live electrical circuits.
6. Make sure that all components are grounded correctly and that they obey the local electrical safety requirements.
7. Install the necessary precautions to supply safety and protection to the operator.



DANGER: System travel can cause crush, shear, or pinch injuries. Restrict access to all motor and stage parts while your system is connected to a power source.



WARNING: To prevent damage to the equipment and decrease the risk of electrical shock and injury, obey the precautions that follow.

1. Make sure that all system cables are correctly attached and positioned.
2. Do not use the cables or the connectors to lift or move this product.
3. Use this product only in environments and operating conditions that are approved in this manual.
4. Only trained operators should operate this equipment.

Handling and Storage

Unpacking the drive



IMPORTANT: All electronic equipment and instrumentation is wrapped in antistatic material and packaged with desiccant. Ensure that the antistatic material is not damaged during unpacking.

Inspect the shipping container for any evidence of shipping damage. If any damage exists, notify the shipping carrier immediately.

Remove the packing list from the shipping container. Make sure that all the items specified on the packing list are contained within the package.

The documentation for the drive is on the included installation device. The documents include manuals, interconnection drawings, and other documentation pertaining to the system. Save this information for future reference. Additional information about the system is provided on the Serial and Power labels that are placed on the chassis.

The system serial number label contains important information such as the:

- Customer order number (please provide this number when requesting product support)
- Drawing number
- System part number

Handling



IMPORTANT: It is the responsibility of the customer to safely and carefully lift and move the drive.

- Be careful when you move or transport the drive.
- Refer to [Section 1.5. Mechanical Specifications](#) for dimensions and weight specifications.
- Retain the shipping materials for future use.
- Transport or store the drive in its protective packaging.



WARNING: Electrostatic Discharge (ESD) Sensitive Components!

You could damage the power supply or drives if you fail to observe the correct ESD practices. Wear an ESD wrist strap when you handle, install, or do service to the system assembly.

Storage

Store the drive in the original shipping container. If the original packaging included ESD protective packaging, make sure to store the drive in it. The storage location must be dry, free of dust, free of vibrations, and flat.

Refer to [Section 1.6. Environmental Specifications](#).

Installation Overview

The images that follow show the order in which to make connections and settings that are typical to the iXC4e/XC4e. If a custom interconnect drawing was supplied with your system, that drawing is on your Storage Device and shows as a line item on your Sales Order in the Integration section.

Figure 1: Installation Connection Overview for the iXC4e

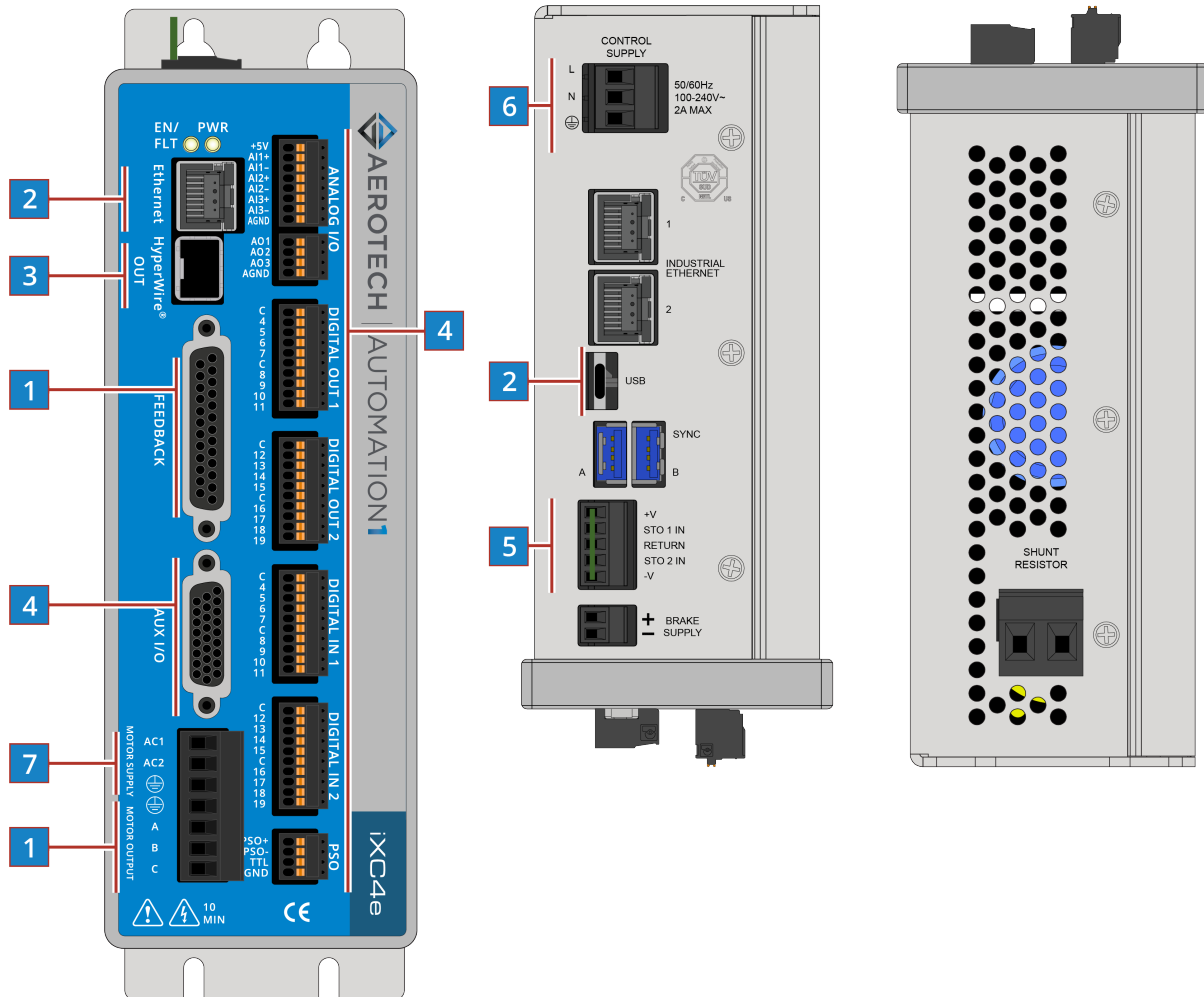

1	Connect the motor to the amplifier Motor Output connector.	Section 2.2.
	Connect the motor to the amplifier Feedback connector.	Section 2.3.
2	Connect the PC to the USB or Ethernet port.	N/A
3	Connect the next drive in the system to the HyperWire Out port.	Section 2.7.
4	Connect additional I/O as required by your application (if you purchased the I/O option).	Section 2.5./ Chapter 3
5	Connect the Safe Torque Off (STO).	Section 2.4.
6	Connect the power supply to the Control Supply connector.	Section 2.1.1.
7	Connect the motor power to the Motor Supply connector.	Section 2.1.2.

Figure 2: Installation Connection Overview for the XC4e

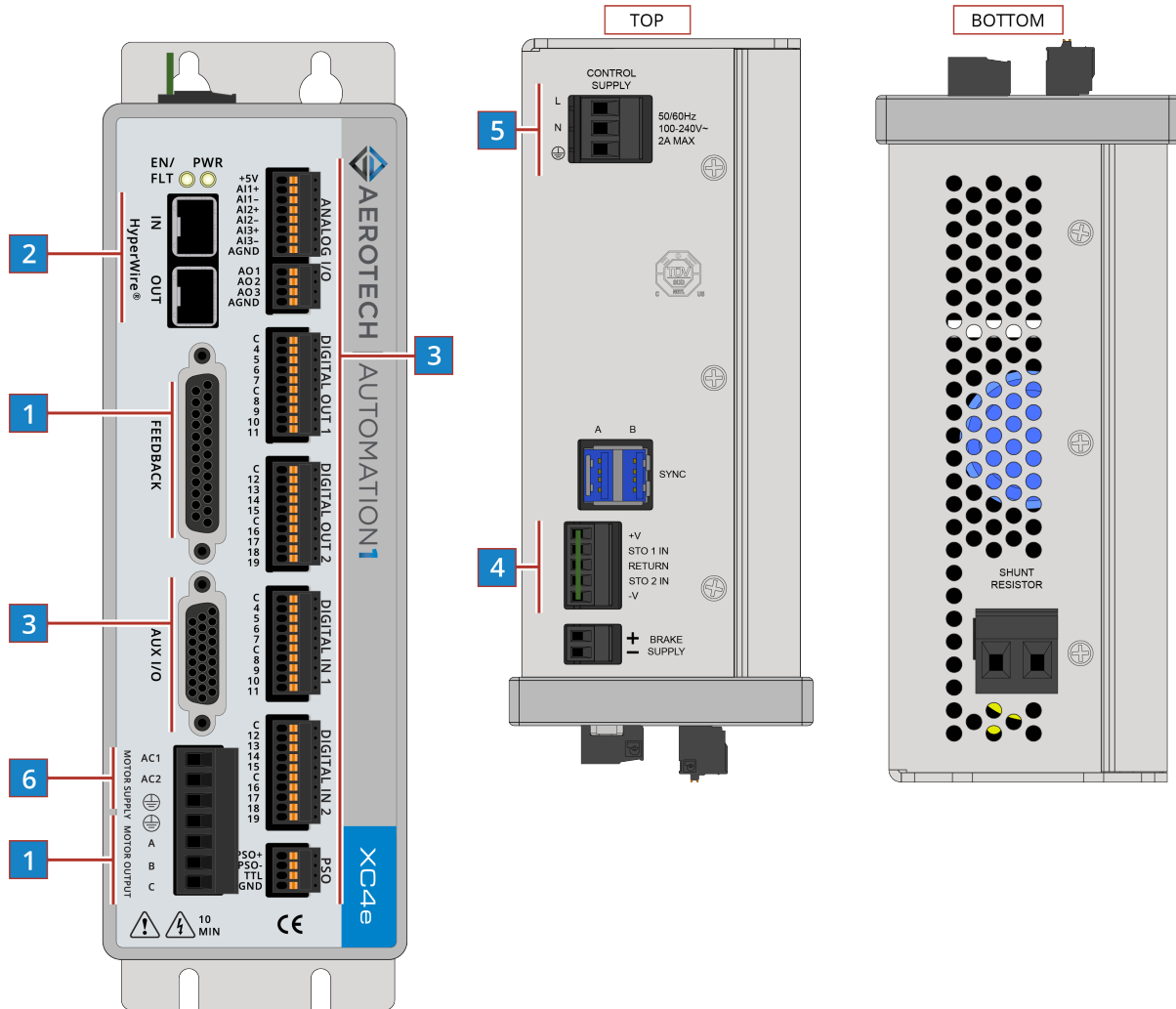

1	Connect the motor to the amplifier Motor Output connector.	Section 2.2.
	Connect the motor to the amplifier Feedback connector.	Section 2.3.
2	Connect a PC or drive-based controller HyperWire port to the HyperWire In port.	Section 2.7.
3	Connect additional I/O as required by your application (if you purchased the I/O option).	Section 2.5./ Chapter 3
4	Connect the Safe Torque Off (STO).	Section 2.4.
5	Connect the power supply to the Control Supply connector.	Section 2.1.1.
6	Connect the motor power to the Motor Supply connector.	Section 2.1.2.

This page intentionally left blank.

Chapter 1: iXC4e/XC4e Overview

The iXC4e is a high-performance digital drive-based controller. It runs the Automation1-iSMC controller to generate commands for itself as well as for additional drives on the chain.

The XC4e is a high performance digital drive. The XC4e is based on the HyperWire communication protocol and receives commands from a PC or drive-based controller.

Both drives provide deterministic behavior, auto-identification, and are fully software configurable. A double precision floating point DSP controls the digital PID and current loops. Both drives offer standard Safe Torque Off (STO) inputs and optional Position Synchronized Output (PSO) outputs. And both drives are offered with optional encoder interpolation features (-MX2/-MX3), an auxiliary encoder input for dual loop control, dedicated analog and digital I/O (expandable with the -EB1 option), and separate power connections for motor and control supply voltages.

Figure 1-1: iXC4e Digital Drive-Based Controller

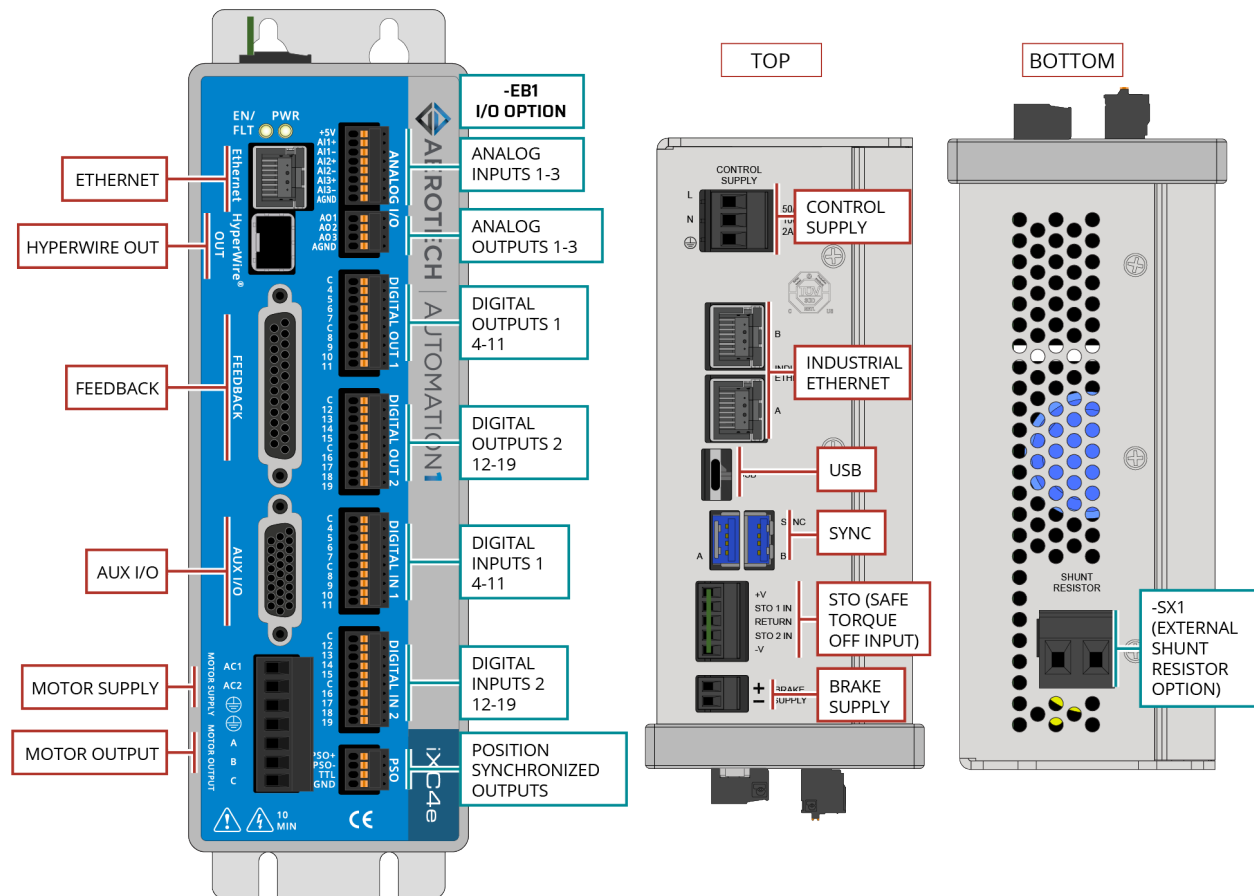
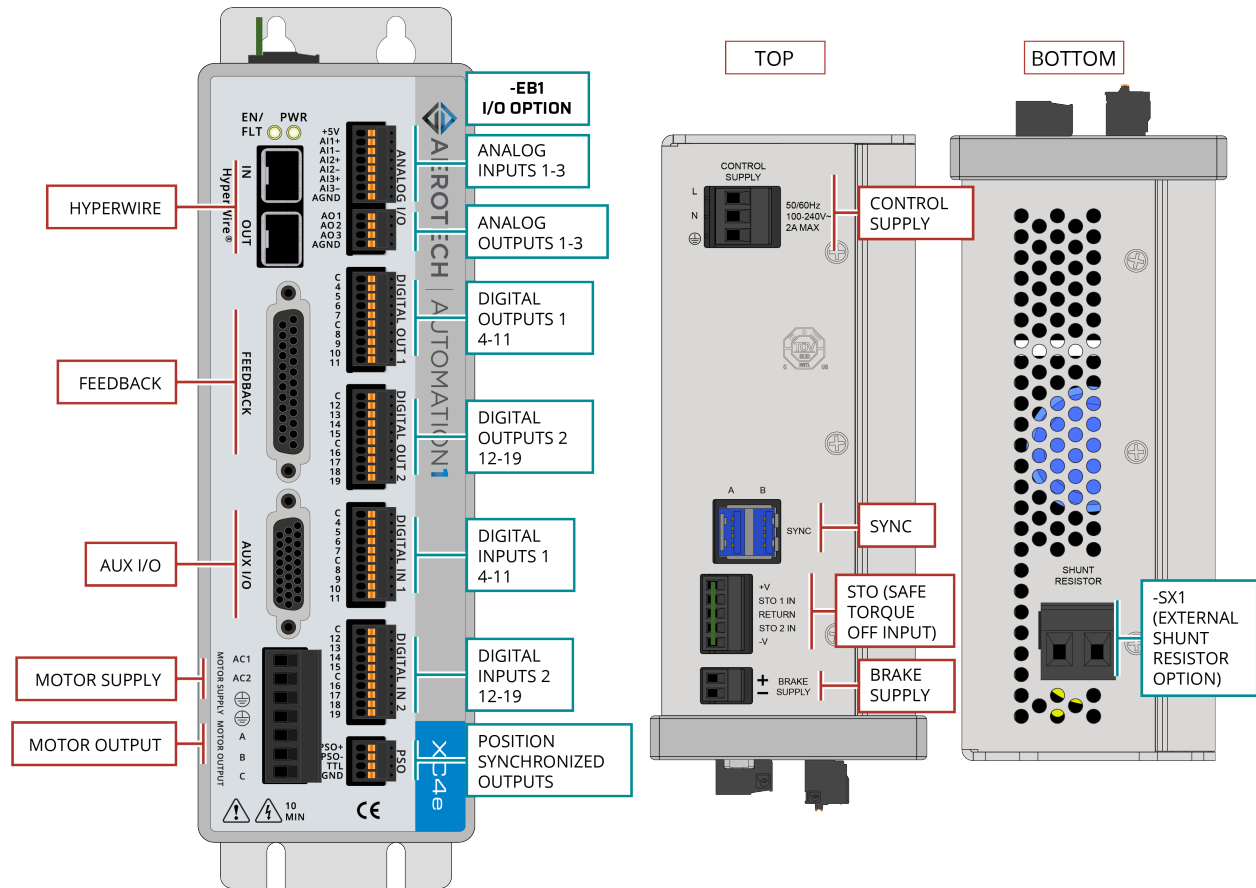

Figure 1-2: XC4e Digital Drive



1.1. Feature Summary

- 100-240 VAC control supply inputs ([Section 2.1.1.](#))
- 0-240 VAC motor supply inputs (producing 340 VDC) ([Section 2.1.2.](#))
- 20 kHz Servo Loop Update Rate
- Line driver square wave quadrature encoder input for position and velocity feedback ([Section 2.3.1.](#))
- Absolute Encoder support on the Feedback Connector ([Section 2.3.1.2.](#))
- One fail-safe brake output ([Section 2.3.6.](#))
- Two STO sense inputs ([Section 2.4.](#))
- Line driver square wave auxiliary quadrature encoder input or output for PSO ([Section 2.5.1.](#))
- Absolute Encoder support on the Auxiliary I/O Connector ([Section 2.5.1.2.](#))
- Four digital user outputs ([Section 2.5.3.](#))
- Six digital user inputs
 - Four Digital Inputs ([Section 2.5.4.](#))
 - Two High-Speed Inputs ([Section 2.5.5.](#))
- One 16-bit analog output (± 10 V) ([Section 2.5.6.](#))
- One 16-bit differential analog input (± 10 V) ([Section 2.5.7.](#))
- Position Synchronized Outputs (PSO):
 - Generate outputs synchronized to feedback positioning ([Section 2.5.2.](#))
 - Part-Speed PSO Firing:
 - One to three axes (one axis is the default)
 - Part-Speed PSO commands high-speed, low-latency output pulses based on the commanded vector velocity. Refer to the online help for more information.
 - Multi-Axis PSO Tracking: To track multiple axes...
 - with Aerotech drives, use the Sync Ports ([Section 2.9.](#))
 - with non-Aerotech drives and square wave encoder signals, use the Auxiliary Encoder connector ([Section 2.5.](#))
 - with non-Aerotech drives and sine wave (-MX2 or -MX3 option required) or square wave encoder signals, use the Primary Feedback connector ([Section 2.3.](#))
- One HyperWire communication channel ([Section 2.7.](#))
- One 10/100/1000 BASE-T Ethernet Port (**iXC4e Only**)
- One USB 2.0 Type C Port (**iXC4e Only**)
- Two 100 BASE-T Industrial Ethernet Ports (**iXC4e Only**)

1.2. Ordering Options

Table 1-1: Example Order and Ordering Options

Example	
Automation1-iXC4e-20-EB1-MX2-PSO6-SX1	
Options	
Automation1 Drive	
-XC4e	Enhanced PWM Servo Drive
-iXC4e	Enhanced PWM Servo Drive with Motion Controller
Peak Current (Section 1.4.)	
-10	10 A Peak, 5 A Continuous Current
-20	20 A Peak, 10 A Continuous Current
-30	30 A Peak, 10 A Continuous Current
Expansion Board (Chapter 3)	
-EB0	No expansion board
-EB1	I/O expansion board <ul style="list-style-type: none"> • Three 16-bit analog outputs (± 10 V) • Three 16-bit differential analog inputs (± 10 V) • 16 digital logic inputs (5 - 24 VDC); connect to current sourcing or sinking devices • 16 digital logic outputs (5 - 24 VDC); user defined as current sourcing or sinking • Digital logic laser firing (PSO) output
Multiplier (Section 2.3.1.3.)	
-MX0	No encoder multiplier
-MX2	Interpolation circuit allowing for analog sine wave input on the primary encoder channel with an interpolation factor of 65,536.
-MX3	Interpolation circuit allowing for analog sine wave input on the primary encoder channel with an interpolation factor of 65,536 and an auxiliary encoder channel with an interpolation factor of 16,384.
PSO (Section 2.5.2.)	
-PSO1	One-axis PSO firing (includes One-axis Part-Speed PSO)
-PSO2	Two-axis PSO firing (includes Two-axis Part-Speed PSO)
-PSO3	Three-axis PSO firing (includes Three-axis Part-Speed PSO)
-PSO5	Two-axis Part-Speed PSO firing, which uses the PSO firing circuit based off of the commanded vector velocity of up to 2 axes (includes One-Axis PSO).
-PSO6	Three-axis Part-Speed PSO firing, which uses the PSO firing circuit based off of the commanded vector velocity of 3 or more axes (includes One-Axis PSO).
External Shunt (Section 2.8.)	
-SX0	No connector for the External Shunt
-SX1	Connection provided for an external shunt resistor network

1.3. Functional Block Diagram

The block diagram that follows shows a summary of the connector signals.

Figure 1-3: Functional Diagram

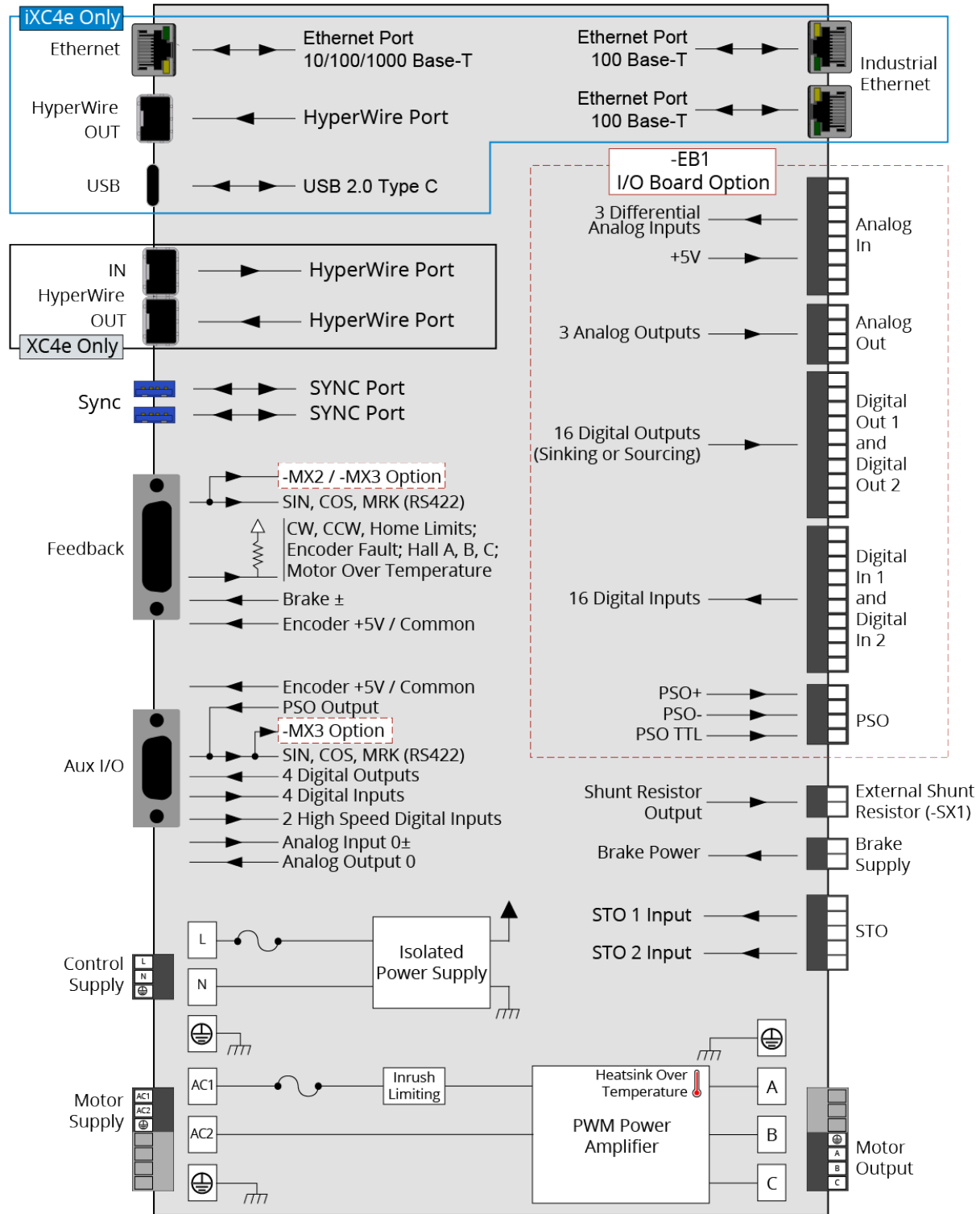

1.4. Electrical Specifications

Table 1-2: Electrical Specifications (Common)

Description		Specification
Control Supply	Input Voltage	100-240 VAC ($\pm 10\%$)
	Input Frequency	50-60 Hz
	Inrush Current	68 A _{PK} @ 240 V
	Input Current	0.5 A _{RMS}
	Internal Fuse	2 A/250 V, 35 A interrupt rating, L terminal only
	External Breaker	20 A maximum (Type-C)
SCCR	Suitable for use on a circuit capable of delivering not more than 5,000 rms symmetrical amperes, 240 volts maximum	
Power Amplifier Bandwidth	2500 Hz maximum (software selectable)	
PWM Switching Frequency	20 kHz	
Minimum Load Inductance	0.5 mH	
User Power Supply Output	5 VDC (@ 500 mA)	
Motor Type	Brushless, Brush, Stepper	
Protective Features	<ul style="list-style-type: none"> • Output short circuit • Peak over current • DC bus over voltage • Motor RMS over current • Motor over temperature • Heatsink over temperature • Control power supply under voltage • IGBT supply under voltage • Shunt resistor monitoring 	
Insulation	Over Voltage Category 3	
Conductors	Copper Only, 75 °C ⁽¹⁾	

(1) The wire temperature rating could be higher than 75 °C. The 75 °C reference is for end-use installers when sizing the conductors per NFPA 70 NEC (National Electrical Code) where applicable.

Table 1-3: Electrical Specifications (by Ordering Option)

Output Current Ordering Option	-10	-20	-30
Motor Supply Input Current at full output power	5 A	10 A	10 A
Motor Supply Input Voltage Max ^(1,2) (Vrms AC1 to AC2, +10%)	240 VAC 50/60 Hz		
Output Current (peak) ⁽³⁾	10 A	20 A	30 A
Output Current (continuous) ^(3,4)	3.5 A _{RMS}	5.3 A _{RMS}	5.3 A _{RMS}
Internal time delay fuse (AC1 input only)	5 A	10 A	10 A
Peak Output Voltage	340 V		
Maximum Motor Supply External Breaker	20 A maximum (Type-D)		
Internal Motor Supply Capacitance	1200 μ f		
Capacitor Safe Discharge Time (to 50 V)	10 minutes		
Shunt / Brake Internal Fuse	8 A		

(1) The iXC4e/XC4e uses a single phase motor supply power.
(2) A Lower motor supply voltage may be used. This will result in a reduction of output power.
(3) There are three motor output phases from the drive.
(4) These values are under full output power. Under a lighter load, the continuous output current capability will be higher.

Integral solid state short circuit protection does not provide branch circuit protection. Branch circuit protection must be provided in accordance with the National Electrical Code and any additional local codes.



WARNING: Electric Shock or Fire Hazard! A fault current interruption could be the result of an open branch-circuit protective device. To reduce the risk of fire or electric shock, examine the current-carrying parts and other controller components. Replace all damaged parts. If a burnout of the current element of an overload relay occurs, you must replace the complete overload relay.

AVERTISSEMENT : Risque d'électrocution ou d'incendie ! Une interruption du courant de défaut peut être provoqué par un dispositif de protection de circuit de dérivation ouvert. Pour réduire le risque d'incendie ou d'électrocution, examinez les pièces conductrices de courant et les autres composants du contrôleur. Remplacer toutes les parties endommagées. Si un grillage de l'élément de courant d'un relais de surcharge se produit, vous devez remplacer le relais de surcharge dans son ensemble.

1.4.1. System Power Requirements

The following equations can be used to determine total system power requirements. The actual power required from the mains supply will be the combination of actual motor power (work), motor resistance losses, and efficiency losses in the power electronics or power transformer. For 3-phase brushless motors:

Use an EfficiencyFactor of approximately 90% in the following equations.

PWM Amplifier Types

$$\begin{aligned} \text{Power Output [W]} &= \text{Torque [N}\cdot\text{m]} \cdot \text{Angular Velocity [rad/sec]} \quad ;\text{Rotary} \\ &= \text{Force [N]} \cdot \text{Linear Velocity [m/sec]} \quad ;\text{Linear} \\ &= B_{\text{emf}} [V_{\text{rms}} \text{ l-n}] \cdot \text{MotorCurrent [A}_{\text{rms}}] \cdot 3 \quad ;\text{Rotary or Linear} \\ \text{Power Loss [W]} &= \text{MotorCurrent}^2 [\text{A}_{\text{rms}}^2] \cdot \text{MotorHotResistance } [\Omega \text{ l-l}] \cdot 3/2 \\ \text{Power Input [W]} &= (\text{Power Output [W]} + \text{Power Loss [W]}) / \text{EfficiencyFactor} \end{aligned}$$

NOTES

l-n = line to neutral
 l-l = line to line
 Vrms = Volt rms
 Arms = Ampere rms
 Apk = Ampere peak
 Vdc = Volt DC

1.4.2. Real-Time Clock Requirements (iXC4e Only)

The drive has an internal real-time clock that is used to time-stamp logged data. The clock is powered by an internal capacitor when the control supply is not connected to the drive. When the capacitor is fully charged, it will power the clock for 17.5 days.

If the capacitor is fully discharged, the time on the drive is not reliable. To reinitialize the real-time clock, you must:

- Connect the drive to the control supply. It will take 36 minutes to fully charge the capacitor.
- Connect the drive to the Automation1 Studio and reprogram the real-time clock.

The capacitor charges exponentially with a 7.2 minute time constant. Apply the control supply to charge the capacitor. To achieve the maximum 17.5 days of real-time clock operation in the absence of the control supply, the capacitor must be charged for 36 minutes. If the capacitor is not fully charged when the control supply is lost, the real-time clock will not last the entire 17.5 days on backup capacitor power.

1.5. Mechanical Specifications

1.5.1. Mounting and Cooling

The drive must be installed in an enclosed control cabinet suitable for installation of power equipment. A minimum enclosure rating of IP54 is required to comply with safety standards. Make sure that there is sufficient clearance surrounding the drive for free airflow and for the routing of cables and connections. Consideration for items such as line reactors, line filters, and motor chokes or inductance should be made during the initial cabinet design phase.



IMPORTANT: The amount of airflow required to keep the drive temperature within a sufficient range is dependent on the operating conditions. You could be required to supply additional airflow to the drive.

Table 1-4: Mounting Specifications

		iXC4e/XC4e
Customer-Supplied Enclosure		IP54 Compliant
Weight		2.4 kg
Mounting Hardware		M4 [#8] screws (four locations, not included)
Mounting Orientation		Vertical (typical)
Dimensions		Refer to Section 1.5.2. Dimensions
Minimum Clearance	Airflow	~25 mm
	Connectors	~100 mm
Operating Temperature		Refer to Section 1.6. Environmental Specifications
Drive IP Rating		IP20
Mounting Panel Thickness (Recommended)		2.5 - 3.5 mm (.10 - .125 in)
UL Enclosure Type Rating of Drive		Open Type

1.5.2. Dimensions



IMPORTANT: iXC4e and XC4e dimensions are the same. iXC4e is shown.

Figure 1-4: Dimensions

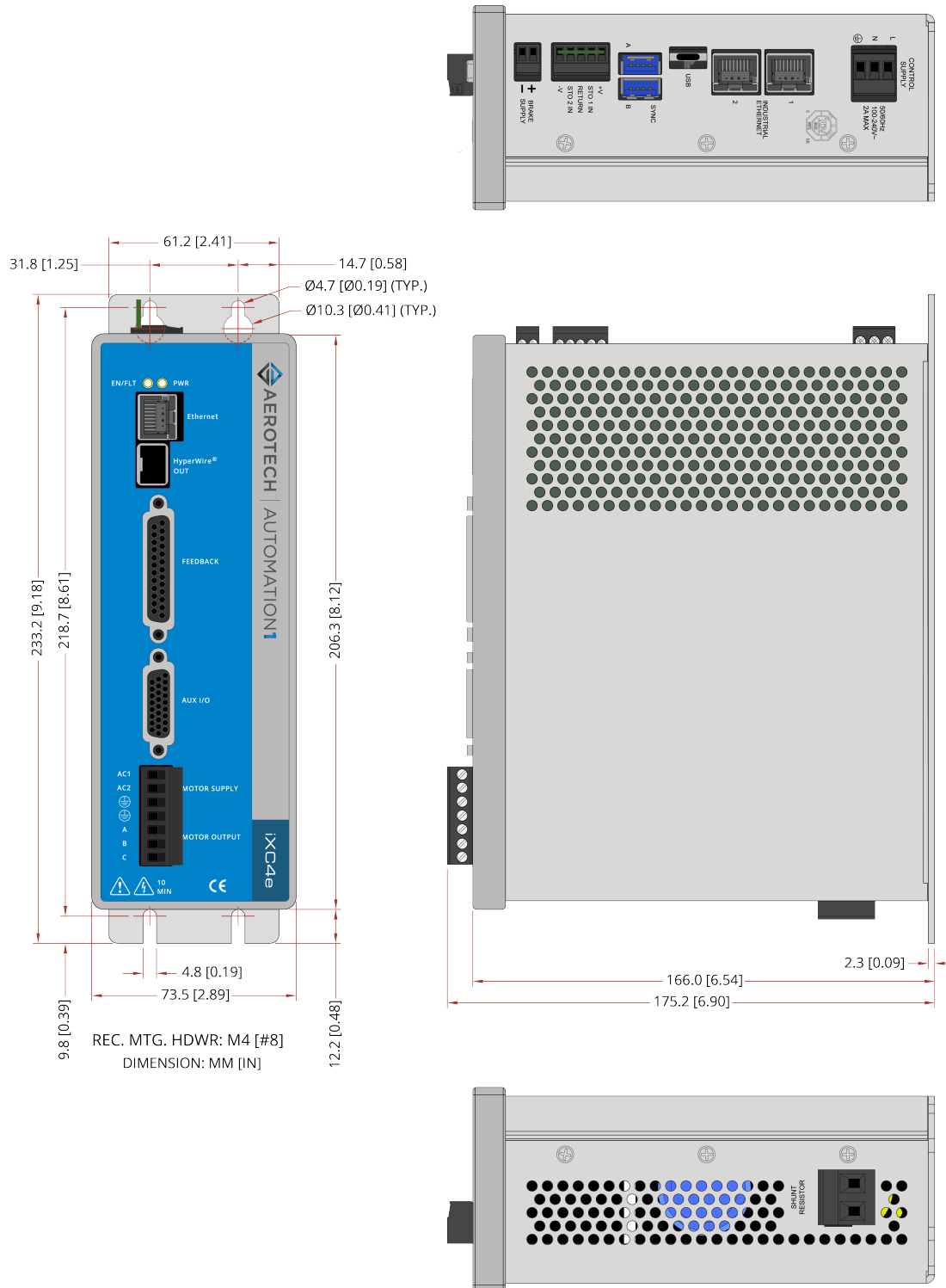



IMPORTANT: iXC4e-EB1 and XC4e-EB1 dimensions are the same. iXC4e-EB1 is shown.

Figure 1-5: Dimensions [-EB1]

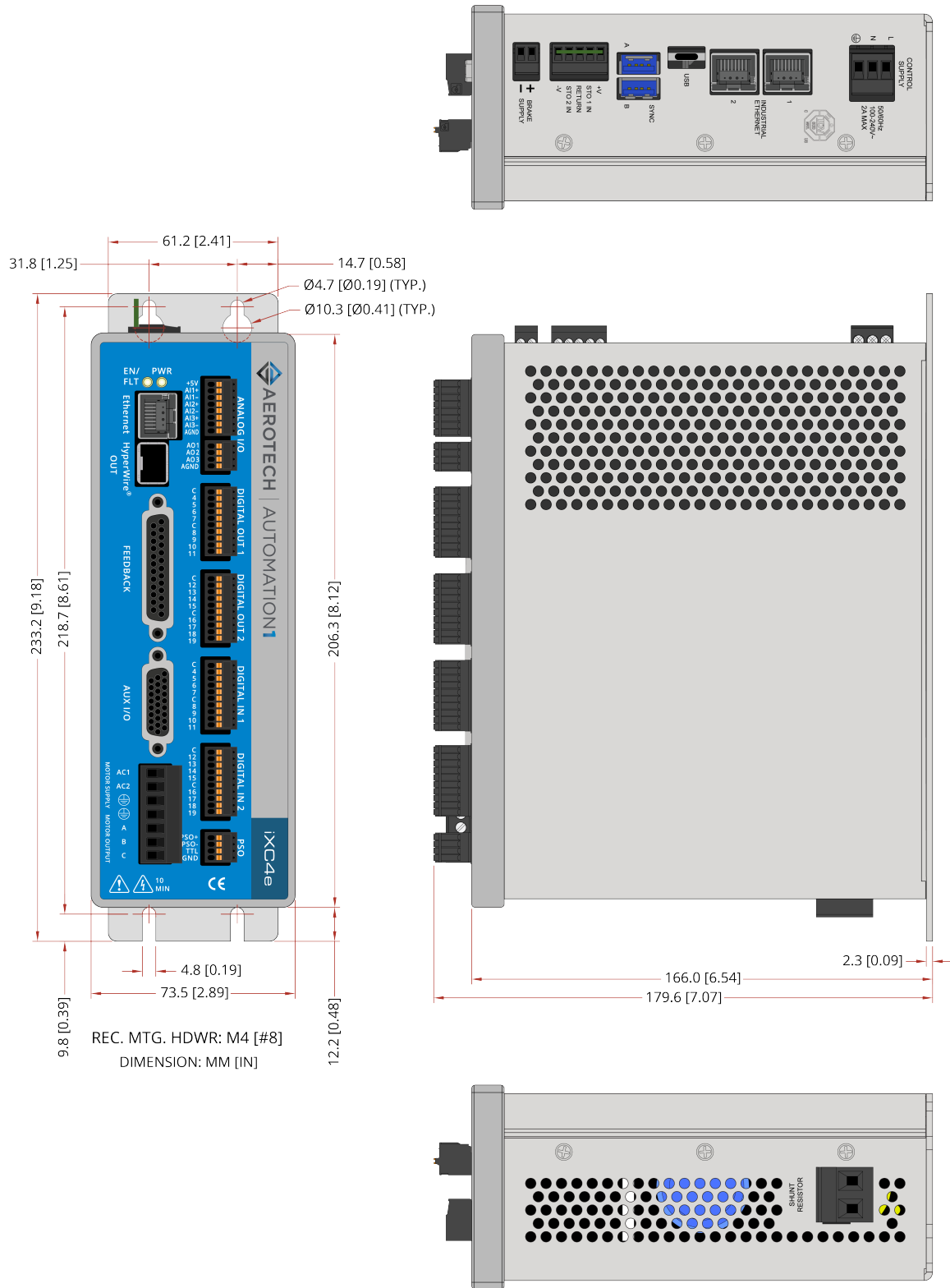

1.6. Environmental Specifications

The environmental specifications are listed below.

Table 1-5: Environmental Specifications

Temperature	Operating: 0 °C to 40 °C (32 °F to 104 °F)
	Maximum Surrounding Air: 40 °C (104 °F)
	Storage: -30 °C to 85 °C (-22 °C to 185 °F)
Humidity Non-condensing	The maximum relative humidity is 80% for temperatures that are less than 31 °C and decreases linearly to 50% relative humidity at 40 °C.
Operating Altitude	0 m to 2,000 m (0 ft to 6,562 ft) above sea level.
Pollution	Pollution Degree 2 Typically only nonconductive pollution occurs.
Operation	Use only indoors

1.7. Drive and Software Compatibility

This table shows the available drives and which version of the software first supported each drive. In the **Last Software Version** column, drives that show a specific version number are not supported after that version.

Table 1-6: Drive and Software Compatibility

Drive Type	Software	First Software Version	Last Software Version
iXC4e	Automation1	2.0.0	Current
XC4e	Automation1	1.2.0	Current
	A3200	6.04	Current

This page intentionally left blank.

Chapter 2: Installation and Configuration

The sections in this chapter include details on how to set up the electrical and safety components of your system. Obey all safety warnings, including those in [Safety Procedures and Warnings](#).

2.1. Input Power Connections

The drive has two AC input power connectors. One connector is for control power and the other connector is for motor power. For a full list of electrical specifications, refer to [Section 1.4](#). Refer to [Section 2.11](#) for a System Interconnection Drawing.

2.1.1. Control Supply Connector



DANGER: Shock and Fire Hazard

Electrical wiring must be designed and installed in accordance with local electrical safety regulations to prevent the risk of fire and electrical shock.

The Control Supply input supplies power to the communications and logic circuitry of the drive. The **L** input is connected to an internal fuse. Refer to [Table 5-4](#) for the internal fuse value and part number. The **N** input is not internally fused. External protection is required if **N** is not connected to a neutral conductor. A dual pole ganged breaker is recommended to protect the control supply wires. Refer to [Table 1-2](#) for more information.

The Control Supply contains an internal filter but you could be required to add an external filter for CE compliance. Install the external filter as close as possible to the drive. Use a Schaffner FN2080 filter, an Aerotech UFM-ST noise filter module, or equivalent device.

Figure 2-1: Control Supply Connections

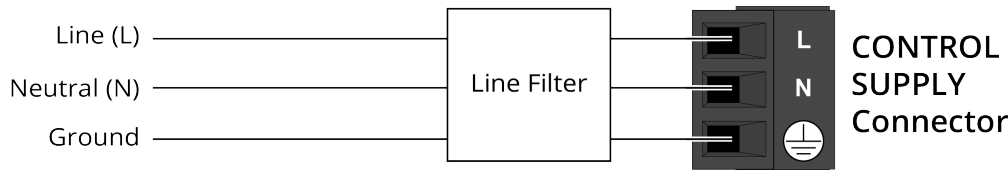

Table 2-1: Control Supply Connector Pinout

Pin	Description
L	Line (L): 100-240 VAC Control Power Input
N	Neutral (N) or 100-240 VAC Control Power Input with external fuse
	Protective Ground

Table 2-2: Control Supply Mating Connector Ratings

Specification		Description
Type		3-Pin Terminal Block
Part Numbers		Aerotech: ECK02388 Phoenix: 1756272
Conductor Cross Section	One conductor, stranded with ferrule and plastic sleeve	14...22 AWG (0.25...2.5 mm ²)
	Two conductors (same cross-section), stranded, twin ferrule with plastic sleeve	16...20 AWG (0.5...1.5 mm ²)
Tightening Torque		0.5...0.6 N·m
Conductor Insulation Strip Length		7 mm (0.25 in)
(1) Refer to the manufacturer website for additional information.		

2.1.2. Motor Supply Connector



DANGER: Shock and Fire Hazard!

Electrical wiring must be designed and installed in accordance with local electrical safety regulations to prevent the risk of fire and electrical shock.

Motor power is applied to the **AC1** and **AC2** terminals of the Motor Supply connector.

Peak Current Option -10: The **AC1** input is internally connected to a 5 A fuse.

Peak Current Option -20 and -30: The **AC1** input is internally connected to a 10 A fuse.

Refer to [Table 5-4](#) for the internal fuse part numbers.

The **AC2** input is not internally fused. The system designer must provide external circuit breaker(s) in accordance with local electrical safety requirements. D-type breakers are required for proper branch protection (refer to [Section 1.4.](#)). Individual circuit breakers could be required for each drive in a system. The size of the breaker required is dependent upon the gauge of wire used between the drive and the motor.

The drive contains an internal surge protector (MOV, P/N: P20V385) between the internal motor supply and ground. For hi-pot testing, you will need to temporarily remove JP100 (refer to [Figure 5-1](#)).

For CE compliance, connect an AC line filter as close as possible to the drive (refer to [Section 2.1.4.](#)).



WARNING: Verify that all ground connections are installed correctly before you apply power to the iXC4e/XC4e.

Figure 2-2: Motor Supply Connections



Table 2-3: Motor Supply Connector Pinout

Pin	Description
AC1	AC Motor Power Input
AC2	AC Motor Power Input
⊕	Protective Earthing Conductor - 2.5 mm ² / 14 AWG min conductor size

Table 2-4: Motor Supply Mating Connector Ratings

Specification		Description
Type		7-Pin Terminal Block
Part Numbers		Aerotech: ECK02387 Phoenix: 1756353
Conductor Cross Section	One conductor, stranded with ferrule and plastic sleeve	14...22 AWG (0.25...2.5 mm ²)
	Two conductors (same cross-section), stranded, twin ferrule with plastic sleeve	16...20 AWG (0.5...1.5 mm ²)
Tightening Torque		0.5...0.6 N·m
Conductor Insulation Strip Length		7 mm (0.25 in)

(1) Refer to the manufacturer website for additional information.

Use these parameters to configure motor overload protection: AverageCurrentThreshold, AverageCurrentTime, and MaxCurrentClamp.

2.1.3. Transformer Options

You can connect an external isolation transformer to the Motor Supply AC Input to reduce the operating voltage of the motor. Using a transformer can also reduce electrical noise.

Table 2-5: Nominal Motor Operating Voltages / Required AC Voltages

AC Voltage	DC Voltage
28	40
56	80
115	160
230	320

Table 2-6: Transformer Options

Transformer	Description
TV0.3-28-56-ST	Generate 28 or 56 VAC from 115 VAC or 230 VAC input source voltage. When rectified by the drive, it produces a 40 or 80 VDC power bus.
TM3	Power up to 4 drives, providing 300 watts of power
TM5	Power up to 4 drives providing 500 watts of power
TV0.3-28	Generate 28 VAC from 115 VAC or 230 VAC input source voltage. When rectified by the drive, it produces a 40 VDC power bus.
TV0.3-56	Generate 56 VAC from 115 VAC or 230 VAC input source voltage. When rectified by the drive, it produces an 80 VDC power bus.
TV1.5, TV2.5, or TV5	1.5 kVA, 2.5 kVA, or 5 kVA isolation transformer; 115/230 VAC input; 28, 43, 56, 70, 115 VAC output

Figure 2-3: TV0.3-28-56-ST Transformer Control and Motor Power Wiring (40 VDC Bus)

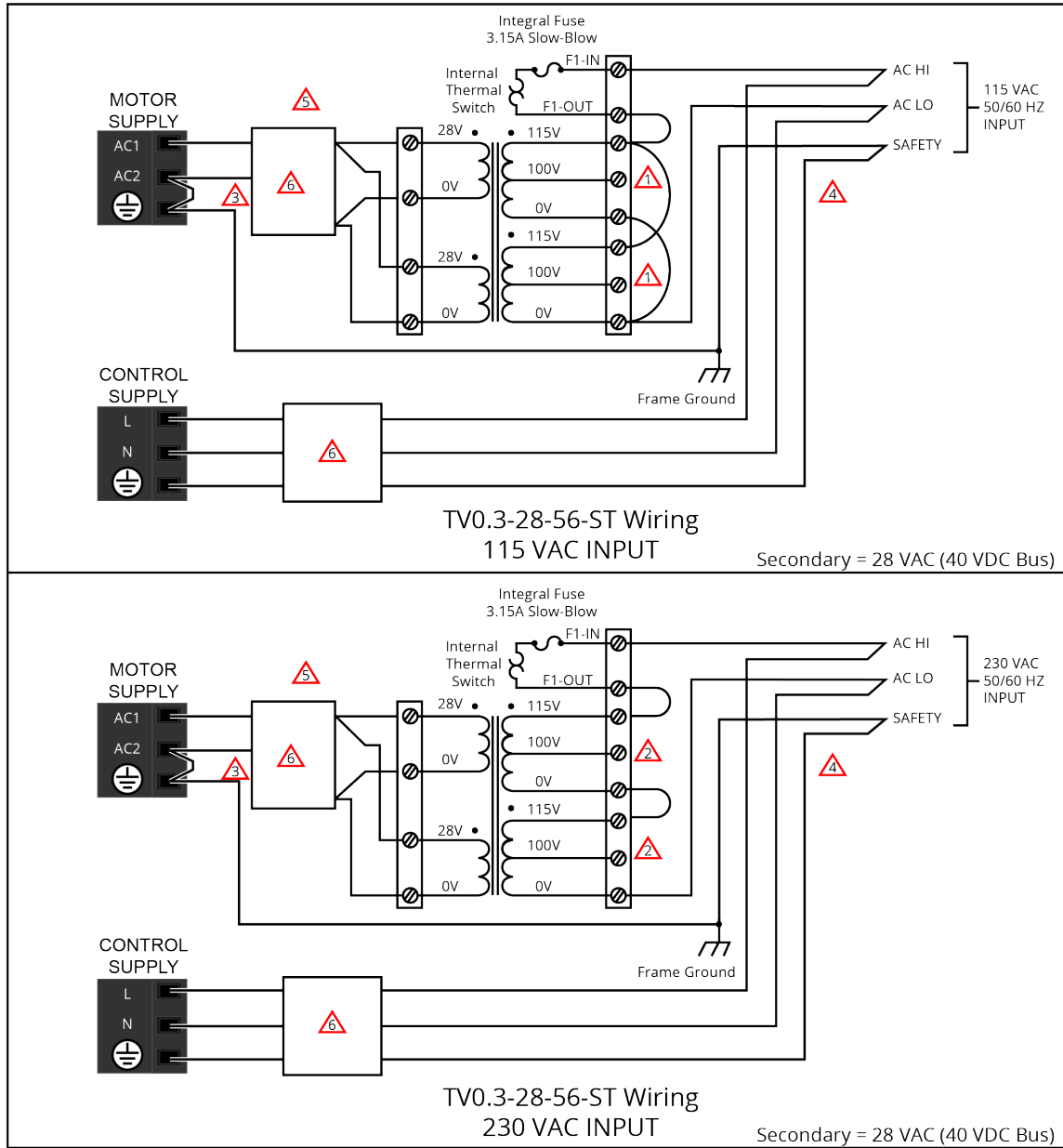

HAZARDOUS VOLTAGES PRESENT **CONNECT ALL WIRING BEFORE POWERING TRANSFORMER** **FOLLOW ALL APPLICABLE WIRING AND SAFETY CODES.**

1. For 100 VAC primary input, parallel the 100 VAC taps and leave the 115 VAC taps unterminated.
2. For 200 VAC primary input, series the 100 VAC taps and leave the 115 VAC taps unterminated.
3. When using an isolation transformer, earth grounding of the AC2 input tap reduces electrical and audible noise emissions and provides increased servo performance.
4. Transformer Primary Wiring: 0.8 mm² (#18 AWG) 300 V wire.
5. Transformer Secondary Wiring: 1.3 mm² (#16 AWG) 300 V wire.
6. AC line filters are for CE compliance. Filters may also be located on the primary side of the transformer.

Drawing: 620B1346-8, Rev. -

Figure 2-4: TV0.3-28-56-ST Transformer Control and Motor Power Wiring (80 VDC Bus)

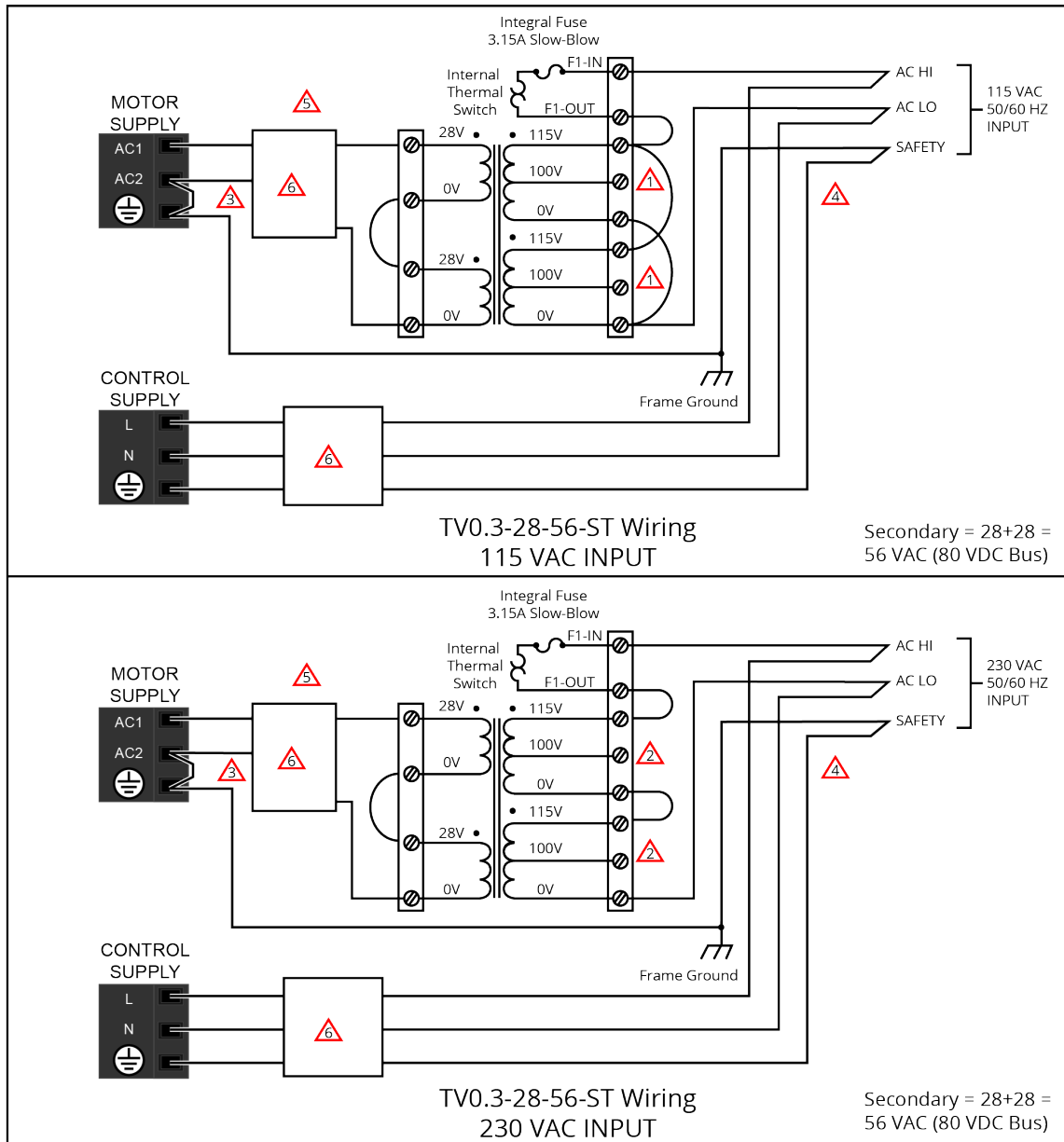

HAZARDOUS VOLTAGES PRESENT



CONNECT ALL WIRING BEFORE POWERING TRANSFORMER



FOLLOW ALL APPLICABLE WIRING AND SAFETY CODES.

1. For 100 VAC primary input, parallel the 100 VAC taps and leave the 115 VAC taps unterminated.
2. For 200 VAC primary input, series the 100 VAC taps and leave the 115 VAC taps unterminated.
3. When using an isolation transformer, earth grounding of the AC2 input tap reduces electrical and audible noise emissions and provides increased servo performance.
4. Transformer Primary Wiring: 0.8 mm² (#18 AWG) 300 V wire.
5. Transformer Secondary Wiring: 1.3 mm² (#16 AWG) 300 V wire.
6. AC line filters are for CE compliance. Filters may also be located on the primary side of the transformer.

Drawing: 620B1346-9, Rev. -

Figure 2-5: TV0.3-28-56-ST Transformer Control and Motor Power Wiring (160 VDC Bus)

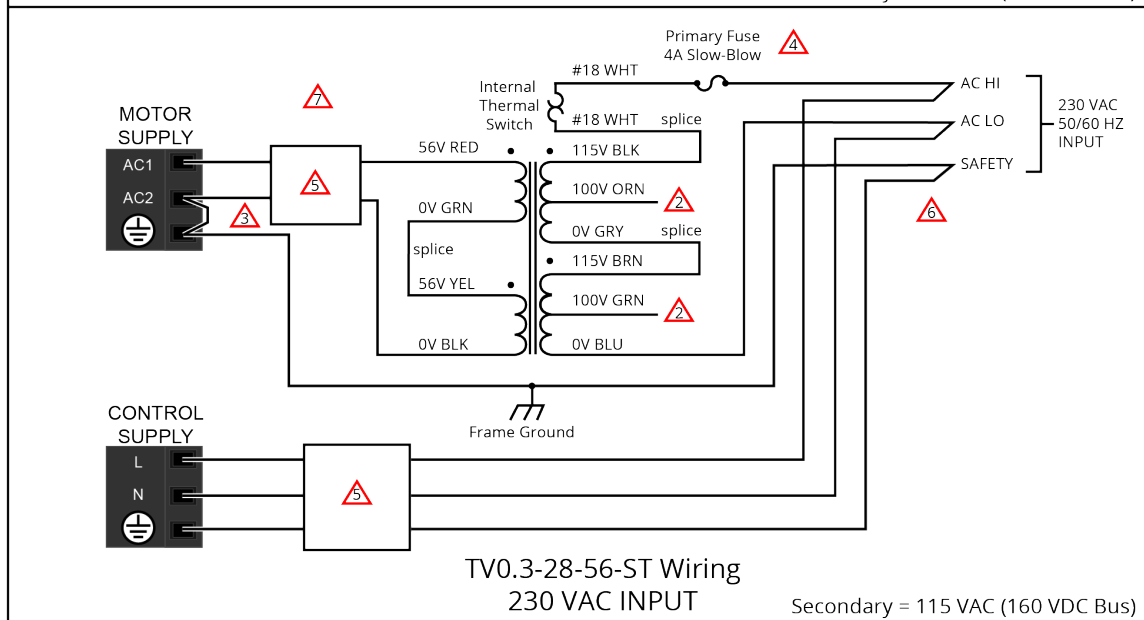
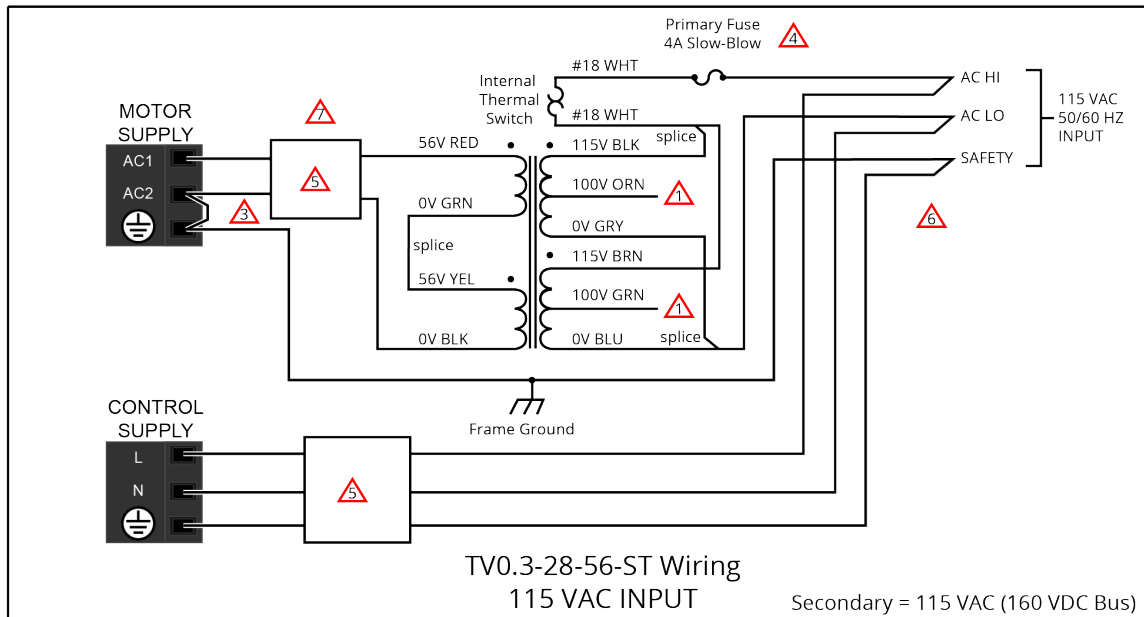

- HAZARDOUS VOLTAGES PRESENT
- CONNECT ALL WIRING BEFORE POWERING TRANSFORMER
- FOLLOW ALL APPLICABLE WIRING AND SAFETY CODES

1. For 100 VAC primary input, parallel the 100 VAC taps and leave the 115 VAC taps unterminated.
2. For 200 VAC primary input, series the 100 VAC taps and leave the 115 VAC taps unterminated.
3. When using an isolation transformer, earth grounding of the AC2 input tap reduces electrical and audible noise emissions and provides increased servo performance.
4. Additional or alternative fusing may be required for optimum protection
5. AC line filters are for CE compliance. Filters may also be located on the primary side of the transformer.
6. Transformer Primary Wiring: 0.8 mm² (#18 AWG) 300 V wire.
7. Transformer Secondary Wiring: 1.3 mm² (#16 AWG) 300 V wire.

Drawing: 620B1346-3

Figure 2-6: TV0.3-28 Transformer Control and Motor Power Wiring (40 VDC Bus)

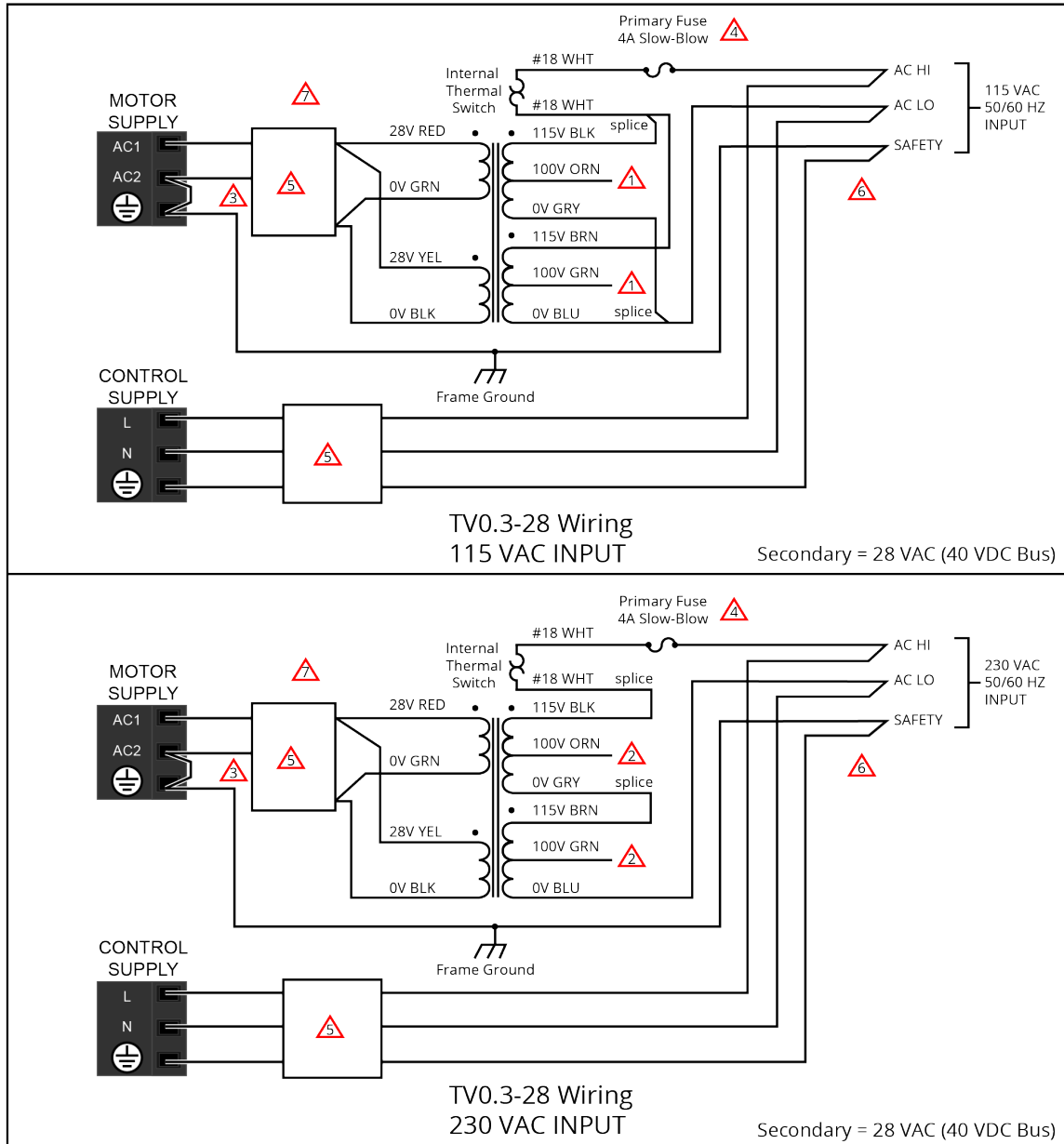

HAZARDOUS VOLTAGES PRESENT **CONNECT ALL WIRING BEFORE POWERING TRANSFORMER** **FOLLOW ALL APPLICABLE WIRING AND SAFETY CODES.**

1. For 100 VAC primary input, parallel the 100 VAC taps and leave the 115 VAC taps unterminated.
2. For 200 VAC primary input, series the 100 VAC taps and leave the 115 VAC taps unterminated.
3. When using an isolation transformer, earth grounding of the AC2 input tap reduces electrical and audible noise emissions and provides increased servo performance.
4. Additional or alternative fusing may be required for optimum protection
5. AC line filters are required for CE compliance. Filters may also be located on the primary side of the transformer.
6. Transformer Primary Wiring: 0.8 mm² (#18 AWG) 300 V wire.
7. Transformer Secondary Wiring: 1.3 mm² (#16 AWG) 300 V wire.

Drawing: 620B1346-1

Figure 2-7: TV0.3-56 Transformer Control and Motor Power Wiring (80 VDC Bus)

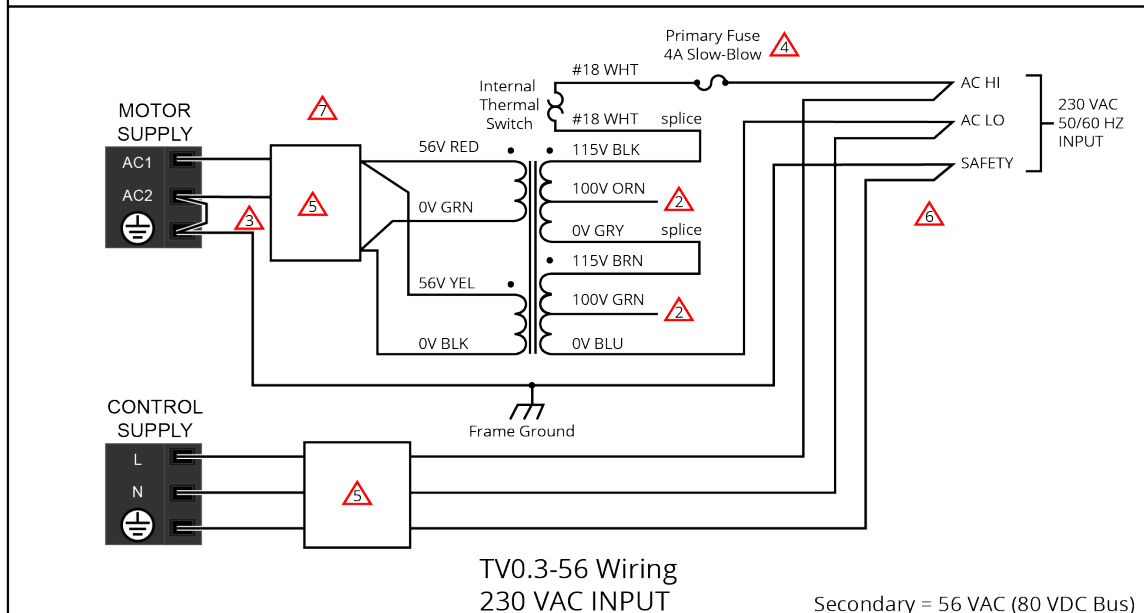
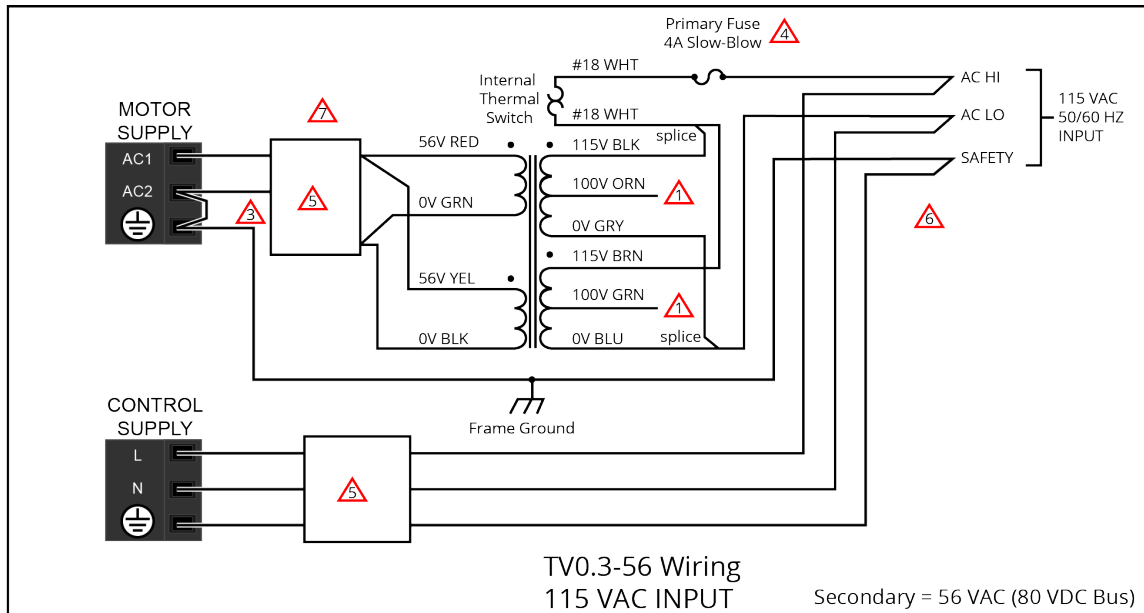

HAZARDOUS VOLTAGES PRESENT



CONNECT ALL WIRING BEFORE POWERING TRANSFORMER



FOLLOW ALL APPLICABLE WIRING AND SAFETY CODES

1. For 100 VAC primary input, parallel the 100 VAC taps and leave the 115 VAC taps unterminated.
2. For 200 VAC primary input, series the 100 VAC taps and leave the 115 VAC taps unterminated.
3. When using an isolation transformer, earth grounding of the AC2 input tap reduces electrical and audible noise emissions and provides increased servo performance.
4. Additional or alternative fusing may be required for optimum protection
5. AC line filters are required for CE compliance. Filters may also be located on the primary side of the transformer.
6. Transformer Primary Wiring: 0.8 mm² (#18 AWG) 300 V wire.
7. Transformer Secondary Wiring: 1.3 mm² (#16 AWG) 300 V wire.

Drawing: 620B1346-2

Figure 2-8: TM3/TM5 Transformer Control and Motor Power Wiring

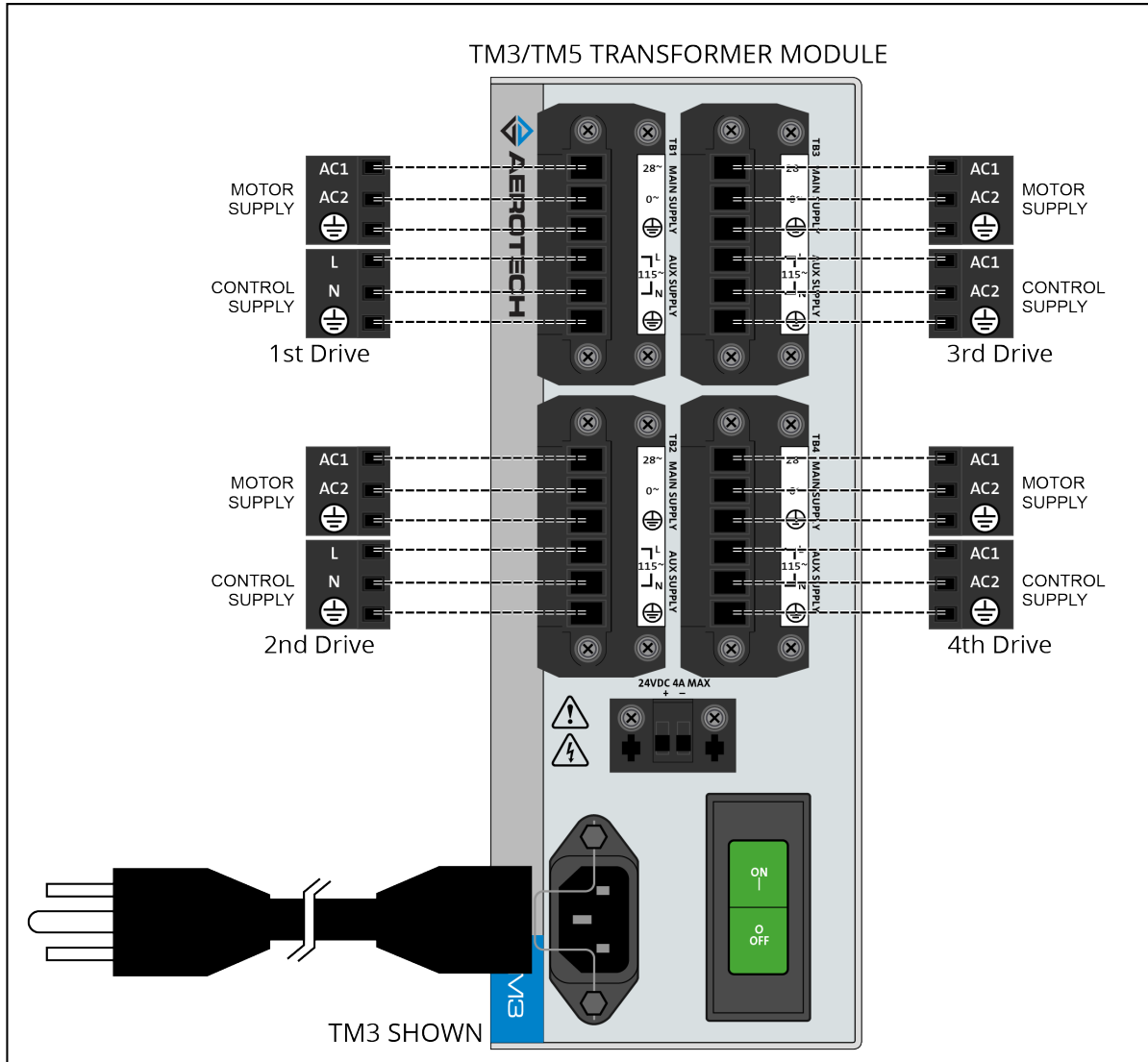

- HAZARDOUS VOLTAGES PRESENT
- CONNECT ALL WIRING BEFORE POWERING TRANSFORMER
- FOLLOW ALL APPLICABLE WIRING AND SAFETY CODES.

1. See the TM3 or TM5 manual for input voltage configuration
2. Wiring Specifications: 1.3 mm² (#16 AWG) 300 V wire.
3. Control Supply output voltage (115 VAC in this example) is always the same as the AC Input Voltage to the unit.

2.1.4. Minimizing Noise for EMC/CE Compliance



IMPORTANT: The iXC4e/XC4e is a component designed to be integrated with other electronics. EMC testing must be conducted on the final product configuration.

To reduce electrical noise, observe the following motor feedback and input power wiring techniques.

1. Use shielded cable for motor and feedback connectors. Connect the shield to the backshell.
2. Separate motor and power wiring from encoder and I/O wiring.
3. Mount drives, power supplies, and filter components on a conductive panel. Mount line filters close to the drive to keep the wire length between the drive and filter to a minimum. Use a line filter, such as Aerotech's UFM-ST, on the Motor Supply and Control Supply AC inputs.
4. Use the lowest motor voltage required by the application to reduce radiated emission.
5. Use an isolation transformer with grounded secondary to keep the effects of high frequency PWM amplifier currents to a minimum.
6. Use a separate wire for each ground connection to the drive. Use the shortest possible wire length.

The following additional changes could be required for EMC compliance and are recommended during initial EMC system evaluation.

1. Add a clamp-on ferrite to the feedback cable close to the drive.
[Aerotech PN ECZ02348, Fair-rite PN 0446167281]
2. Add a clamp-on ferrite to the Motor Supply and Control Supply wires, including the ground wire, close to the drive.
[Aerotech PN ECZ02347, Fair-rite PN 0446164281]
3. Add a ferrite core to the UFM-ST AC input wires. Wrap the AC wires and ground wire around the core one time.
[Ferrite core: Aerotech PN ECZ02350, Fair-rite PN 2646102002]
4. Add a ferrite core to the motor phase and ground wires close to the drive. Wrap all four wires around the ferrite core once. Remove ferrite beads from Aerotech supplied cables if installed.
[Ferrite core: Aerotech PN ECZ02349, Fair-rite PN 2646626402]
5. Install a motor filter module MFM10-1 close to the drive. The ferrite core that you added to the motor phase and ground wires should be located between the drive and the MFM10-1.

For typical system interconnections, refer to [Section 2.11. System Interconnection](#).

2.2. Motor Power Output Connector



DANGER: Before you do maintenance to the equipment, disconnect the electrical power. Wait at least ten (10) minutes after removing the power supply before doing maintenance or an inspection. Otherwise, there is the danger of electric shock.

The drive can be used to drive the following motor types:

- Brushless (refer to [Section 2.2.1.](#))
- DC Brush (refer to [Section 2.2.2.](#))
- Stepper (refer to [Section 2.2.3.](#))

For a complete list of electrical specifications, refer to [Section 1.4.](#)



DANGER: Shock and Fire Hazard



Electrical wiring must be designed and installed in accordance with local electrical safety regulations to prevent the risk of fire and electrical shock.

Table 2-7: Motor Power Output Connector Pinout

Pin	Description	Connector
	Motor Ground	
A	Motor Phase A Output	
B	Motor Phase B Output	
C	Motor Phase C Output	

Table 2-8: Motor Power Output Mating Connector Ratings

Specification		Description
Type		7-Pin Terminal Block
Part Numbers		Aerotech: ECK02387 Phoenix: 1756353
Conductor Cross Section	One conductor, stranded with ferrule and plastic sleeve	14...22 AWG (0.25...2.5 mm ²)
	Two conductors (same cross-section), stranded, twin ferrule with plastic sleeve	16...20 AWG (0.5...1.5 mm ²)
Tightening Torque		0.5...0.6 N·m
Conductor Insulation Strip Length		7 mm (0.25 in)
(1) Refer to the manufacturer website for additional information.		

2.2.1. Brushless Motor Connections

The configuration in [Figure 2-9](#) shows a typical brushless motor connection.

Figure 2-9: Brushless Motor Configuration

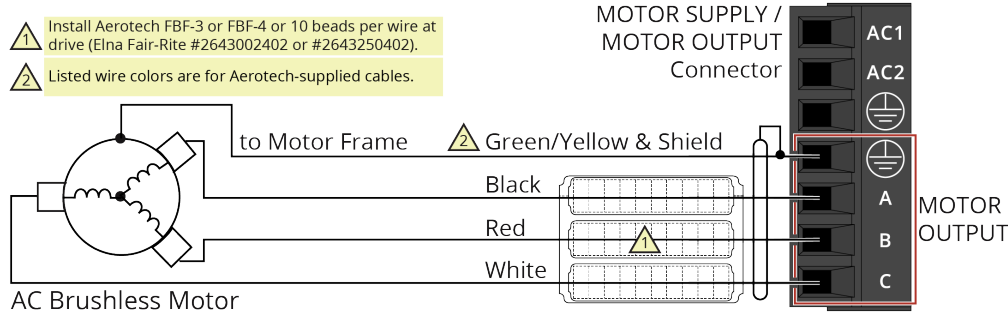

Table 2-9: Wire Colors for Aerotech-Supplied Brushless Motor Cables

Pin	Wire Color Set 1 ⁽¹⁾	Wire Color Set 2	Wire Color Set 3	Wire Color Set 4
Ground	Green/Yellow & Shield ⁽²⁾	Green/Yellow & Shield	Green/Yellow & Shield	Green/Yellow & Shield
A	Black	Blue & Yellow	Black #1	Black & Brown
B	Red	Red & Orange	Black #2	Red & Orange
C	White	White & Brown	Black #3	Violet & Blue

(1) Wire Color Set #1 is the wire set typically used by Aerotech.
 (2) “&” indicates two wires (Red & Orange); “/” indicates a single wire (Green/White).

Brushless motors are commutated electronically by the controller. The use of Hall effect devices for commutation is recommended.

The controller requires that the Back-EMF of each motor phase be aligned with the corresponding Hall-effect signal. To ensure proper alignment, motor, Hall, and encoder connections should be verified using one of the following methods: *powered*, through the use of a test program; or *unpowered* using an oscilloscope. Both methods will identify the A, B, and C Hall/motor lead sets and indicate the correct connections to the controller. Refer to [Section 2.2.1.1.](#) for powered motor phasing or [Section 2.2.1.2.](#) for unpowered motor and feedback phasing.

For Aerotech-supplied systems, the motor, encoder and Hall sensors are correctly configured and connection adjustments are not necessary.

A motor filter module such as the MFM10 can be installed between the drive and the motor, which will reduce the level of PWM amplifier related current spikes in the system.

2.2.1.1. Brushless Motor Powered Motor and Feedback Phasing

Observe the state of the encoder and Hall-effect device signals in the Diagnostics section of the Status Utility.

Table 2-10: Hall Signal Diagnostics

Hall-Signal Status	Definition
--	0 V or logic low
ON	5 V or logic high

Figure 2-10: Positive Motor Direction

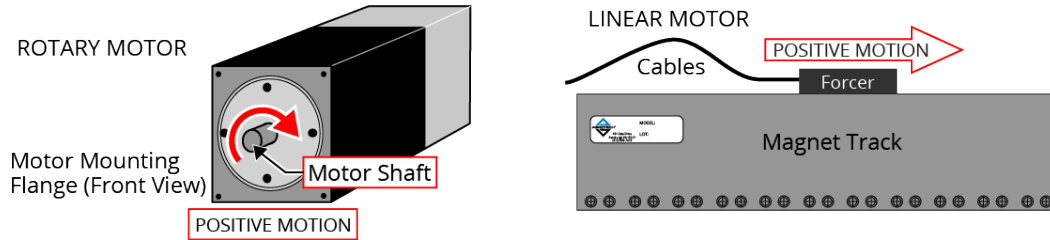

Figure 2-11: Encoder and Hall Signal Diagnostics

Polling rate: Medium

Diagnosics

Data highlighted in blue has not been updated.

Item	X	Y	Z	U
Status				
Position Feedback	000000000000	000000000000	000000000000	000000000000
Position Calibration All	000000000000	000000000000	000000000000	000000000000
Position Camming/Gearing	000000000000	000000000000	000000000000	000000000000
Primary Feedback	000000000000	000000000000	000000000000	000000000000
Hardware				
Enable	--	--	--	--
CW	--	--	--	--
CCW	--	--	--	--
Home	--	--	--	--
Marker	--	--	--	--
Hall A	--	--	--	--
Hall B	--	--	--	--
Hall C	--	--	--	--
ESTOP	--	--	--	--
Brake	--	--	--	--

2.2.1.2. Brushless Motor Unpowered Motor and Feedback Phasing

Disconnect the motor from the controller and connect the motor in the test configuration shown in Figure 2-12. This method will require a two-channel oscilloscope, a 5V power supply, and six resistors (10,000 ohm, 1/4 watt). All measurements should be made with the probe common of each channel of the oscilloscope connected to a neutral reference test point (TP4, shown in Figure 2-12). Wave forms are shown while moving the motor in the positive direction.

Figure 2-12: Brushless Motor Phasing Oscilloscope Example

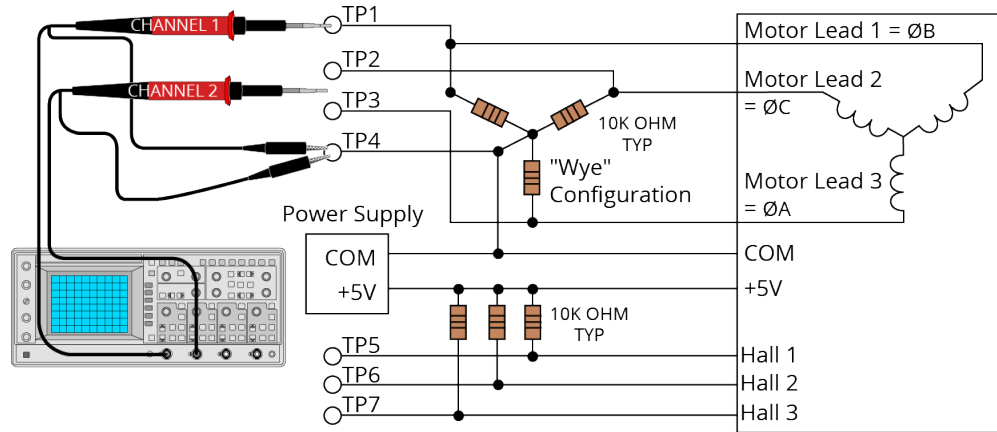

With the designations of the motor and Hall leads of a third party motor determined, the motor can now be connected to an Aerotech system. Connect motor lead A to motor connector A, motor lead B to motor connector B, and motor lead C to motor connector C. Hall leads should also be connected to their respective feedback connector pins (Hall A lead to the Hall A feedback pin, Hall B to Hall B, and Hall C to Hall C). The motor is correctly phased when the Hall states align with the Back EMF as shown in Figure 2-13. Use the CommutationOffset parameter to correct for Hall signal misalignment.

Figure 2-13: Brushless Motor Phasing Goal

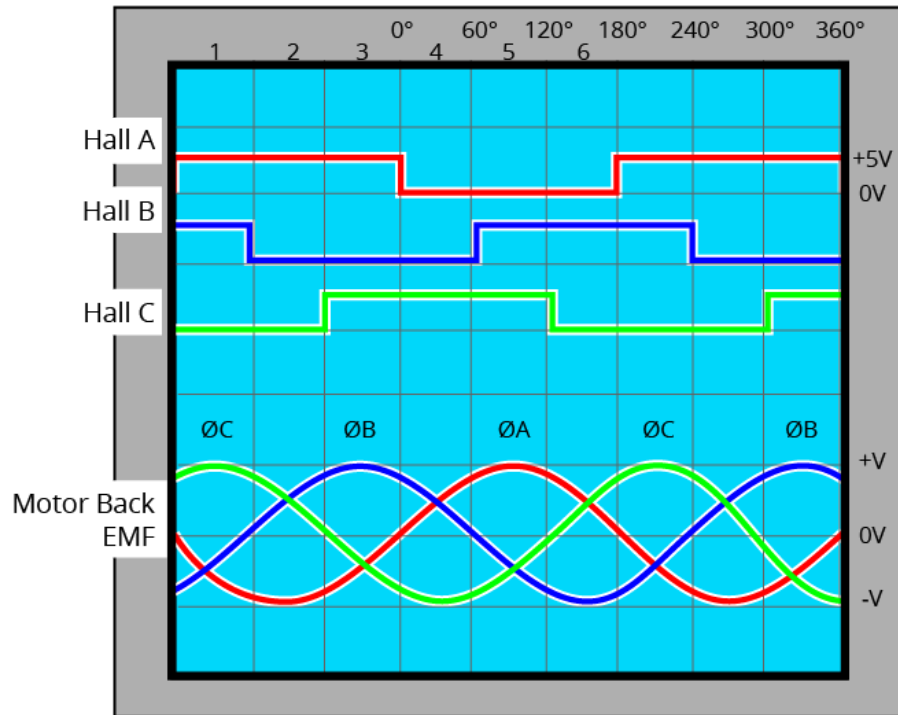

2.2.2. DC Brush Motor Connections

The configuration shown in [Figure 2-14](#) is an example of a typical DC brush motor connection. Refer to [Section 2.2.2.1.](#) for information on motor phasing.

Figure 2-14: DC Brush Motor Configuration

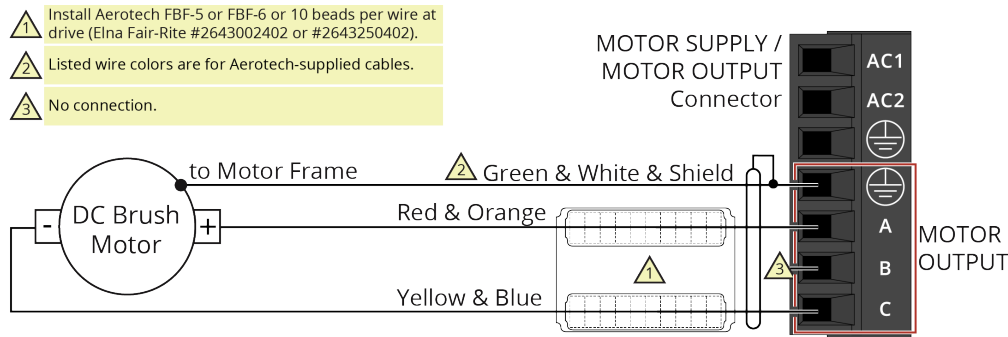

Table 2-11: Wire Colors for Aerotech-Supplied DC Brush Motor Cables

Pin	Wire Color Set 1 ⁽¹⁾	Wire Color Set 2	Wire Color Set 3
⊕	Green & White & Shield ⁽²⁾	Green/Yellow & Shield	Green/Yellow & Shield
A	Red & Orange	Red	Red & Orange
C	Yellow & Blue	Black	Yellow & Blue

(1) Wire Color Set #1 is the typical wire set used by Aerotech.
 (2) "&" (Red & Orange) indicates two wires; "/" (Green/White) indicates a single wire.

2.2.2.1. DC Brush Motor Phasing

A properly phased motor means that the positive motor lead should be connected to the ØA motor terminal and the negative motor lead should be connected to the ØC motor terminal. To determine if the motor is properly phased, connect a voltmeter to the motor leads of an un-powered motor:

1. Connect the positive lead of the voltmeter to the one of the motor terminals.
2. Connect the negative lead of the voltmeter to the other motor terminal.
3. Move or rotate the motor in the positive or clockwise (CW) direction by hand.

Figure 2-15: Positive Motor Direction

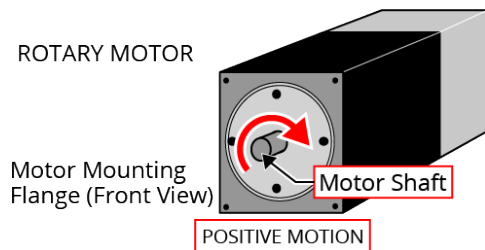

4. If the voltmeter indicates a negative value, swap the motor leads and move the motor by hand in the positive direction, again. When the voltmeter indicates a positive value, the motor leads have been identified.
5. Connect the motor lead from the positive lead of the voltmeter to the ØA motor terminal on the drive. Connect the motor lead from the negative lead of the voltmeter to the ØC motor terminal on the drive.

For Aerotech-supplied systems, the motor, encoder and Hall sensors are correctly configured and connection adjustments are not necessary.

2.2.3. Stepper Motor Connections

The configuration shown in [Figure 2-16](#) is an example of a typical stepper motor connection. Refer to [Section 2.2.3.1.](#) for information on motor phasing.

In this case, the effective motor voltage is half of the applied bus voltage. For example, an 80 V motor bus supply is needed to get 40 V across the motor.

Figure 2-16: Stepper Motor Configuration

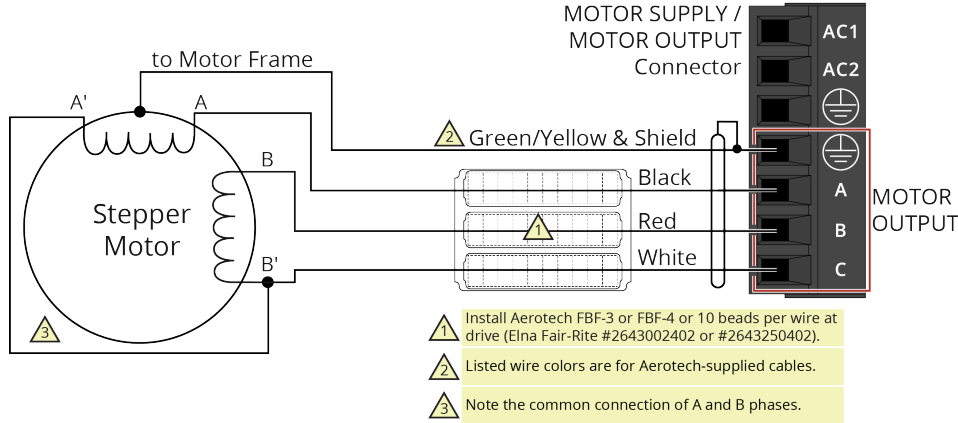

Table 2-12: Wire Colors for Aerotech-Supplied Stepper Motor Cables

Pin	Wire Color Set 1 ⁽¹⁾	Wire Color Set 2
⊕	Green/Yellow & Shield ⁽²⁾	Green/Yellow & Shield
A	Black	Brown
B	Red	Yellow
C	White	White & Red

(1) Wire Color Set #1 is the typical wire set used by Aerotech.
 (2) “&” (Red & Orange) indicates two wires; “/” (Green/White) indicates a single wire.

2.2.3.1. Stepper Motor Phasing

A stepper motor can be run with or without an encoder.

Without an Encoder: You do not need to phase the motor.

With an Encoder: Because the end of travel (EOT) limit inputs are relative to motor rotation, it is important to phase the motor.

Run a positive motion command. The motor is phased correctly if there is a positive scaling factor (determined by the ServoLoopSetup parameter) and the motor moves in a clockwise direction when you view the motor from the front mounting flange ([Figure 2-17](#)). If the motor moves in a counterclockwise direction, reverse the motor leads and re-run the command. After the motor has been phased, if you want to change the direction of positive motion, use the ReverseMotionDirection parameter.

Figure 2-17: Positive Motor Direction

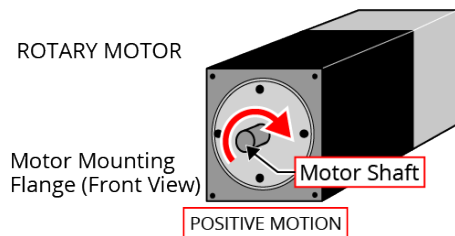

For Aerotech-supplied systems, the motor, encoder and Hall sensors are correctly configured and connection adjustments are not necessary.

2.2.4. Three Phase Stepper Motor Connections



IMPORTANT: This feature is only supported in Automation1 software version 2.2.0. or later.

The configuration shown in [Figure 2-18](#) is an example of a typical three phase stepper motor connection. Refer to [Section 2.2.4.1.](#) for information on motor phasing.

Figure 2-18: Three Phase Stepper Motor Configuration

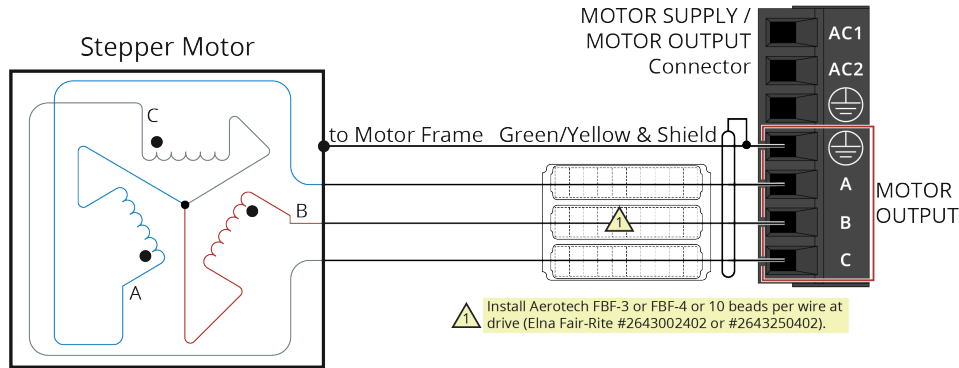

2.2.4.1. Stepper Motor Phasing

A three phase stepper motor can be run with or without an encoder.

Without an Encoder: You do not need to phase the motor.

With an Encoder: Because the end of travel (EOT) limit inputs are relative to motor rotation, it is important to phase the motor.

Run a positive motion command. The motor is phased correctly if there is a positive scaling factor (determined by the ServoLoopSetup parameter) and the motor moves in a clockwise direction when you view the motor from the front mounting flange ([Figure 2-19](#)). If the motor moves in a counterclockwise direction, reverse the motor leads and re-run the command. After the motor has been phased, if you want to change the direction of positive motion, use the ReverseMotionDirection parameter.

Figure 2-19: Positive Motor Direction

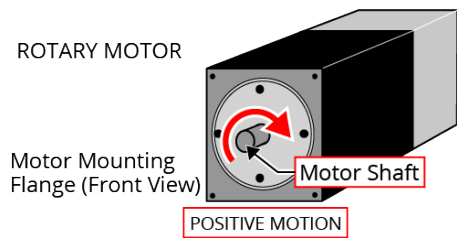

2.3. Feedback Connector

The connector pin assignment is shown in [Table 2-13](#) with detailed connection information in the following sections.

Table 2-13: Feedback Connector Pinout

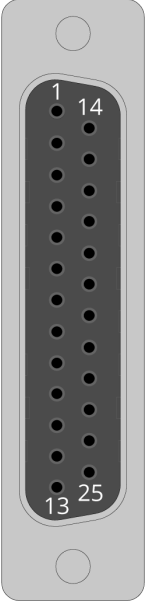
Pin #	Description	In/Out/Bi	Connector
1	Reserved	N/A	
2	Motor Over Temperature Thermistor	Input	
3	+5V Power ⁽¹⁾	Output	
4	Plug and Play Serial Data (for Aerotech stages only)	Bidirectional	
5	Hall-Effect Sensor B (brushless motors only)	Input	
6	Encoder Marker Reference Pulse -	Input	
	Absolute Encoder Clock -	Output	
7	Encoder Marker Reference Pulse +	Input	
	Absolute Encoder Clock +	Output	
8	Absolute Encoder Data -	Bidirectional	
9	Reserved	N/A	
10	Hall-Effect Sensor A (brushless motors only)	Input	
11	Hall-Effect Sensor C (brushless motors only)	Input	
12	Clockwise End of Travel Limit	Input	
13	Brake Output -	Output	
14	Encoder Cosine +	Input	
15	Encoder Cosine -	Input	
16	+5V Power ⁽¹⁾	Output	
17	Encoder Sine +	Input	
18	Encoder Sine -	Input	
19	Absolute Encoder Data+	Bidirectional	
20	Signal Common	Output	
21	Signal Common	Output	
22	Home Switch Input	Input	
23	Encoder Fault Input	Input	
24	Counterclockwise End of Travel Limit	Input	
25	Brake Output +	Output	

(1) The maximum combined current output is 500 mA.

Table 2-14: Feedback Mating Connector Ratings

Specification	25-Pin Solder Cup	Backshell
Aerotech Part Number	ECK00101	ECK00656
Amphenol Part Number ⁽¹⁾	DB25P064TXLF	17E-1726-2
Maximum Wire Size	20 AWG (0.5 mm ²)	N/A

(1) Refer to the manufacturer website for additional information.

2.3.1. Primary Encoder Inputs

The primary encoder inputs are accessible through the Feedback connector. Use the PrimaryFeedbackType [A3200: PositionFeedbackType or VelocityFeedbackType] parameter to configure the drive to accept an encoder signal type.

Square Wave encoder signals: [Section 2.3.1.1.](#)

Absolute encoder signals: [Section 2.3.1.2.](#)

Sine Wave encoder signals (as permitted by the multiplier option): [Section 2.3.1.3.](#)

Refer to [Section 2.3.1.4.](#) for encoder feedback phasing.

Refer to [Section 2.5.](#) for the auxiliary encoder on the Aux I/O connector.

Table 2-15: Multiplier Options

Option	Primary Encoder Accepts...	Auxiliary Encoder Accepts...
-MX0	Square Wave or Absolute encoders	Square Wave or Absolute encoders
-MX2	Sine Wave (high performance), Square Wave, or Absolute encoders	Square Wave or Absolute encoders
-MX3	Sine Wave (high performance), Square Wave, or Absolute encoders	Sine Wave (standard performance), Square Wave, or Absolute encoders



IMPORTANT: Physically isolate the encoder wiring from motor, AC power, and all other power wiring

Table 2-16: Primary Encoder Pins on the Feedback Connector

Pin #	Description	In/Out/Bi
3	+5V Power ⁽¹⁾	Output
6	Encoder Marker Reference Pulse -	Input
	Absolute Encoder Clock -	Output
7	Encoder Marker Reference Pulse +	Input
	Absolute Encoder Clock +	Output
8	Absolute Encoder Data -	Bidirectional
14	Encoder Cosine +	Input
15	Encoder Cosine -	Input
16	+5V Power ⁽¹⁾	Output
17	Encoder Sine +	Input
18	Encoder Sine -	Input
19	Absolute Encoder Data+	Bidirectional
20	Signal Common	Output
21	Signal Common	Output

(1) The maximum combined current output is 500 mA.

2.3.1.1. Square Wave Encoder (Primary)

The drive accepts RS-422 square wave encoder signals. The drive will generate a feedback fault if it detects an invalid signal state caused by an open or shorted signal connection. Use twisted-pair wiring for the highest performance and noise immunity.

Table 2-17: Square Wave Encoder Specifications

Specification	Value
Encoder Frequency	10 MHz maximum (25 ns minimum edge separation)
x4 Quadrature Decoding	40 million counts/sec

Figure 2-20: Square Wave Encoder Schematic (Feedback Connector)

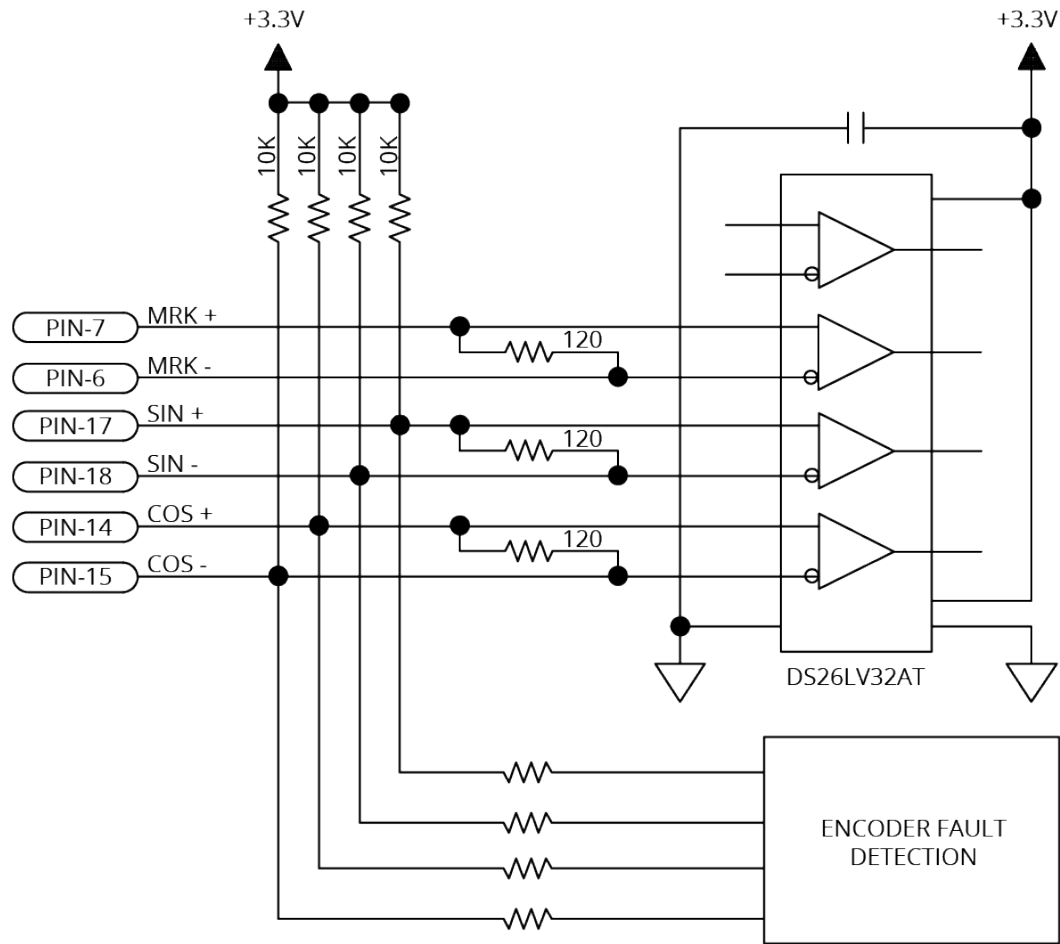

2.3.1.2. Absolute Encoder (Primary)

The drive retrieves absolute position data along with encoder fault information through a serial data stream from the absolute encoder. Use twisted-pair wiring for the highest performance and noise immunity. You cannot echo an absolute encoder signal.

Refer to [Figure 2-21](#) for the serial data stream interface.

Refer to the Help file for information on how to set up your EnDat, BiSS, or SSI absolute encoder parameters.

Table 2-18: Absolute Encoder Specifications

Specification	Value
Sampling Frequency	20 kHz
Maximum Reading Speed	Refer to your encoder data sheet.

Figure 2-21: Absolute Encoder Schematic (Feedback Connector)

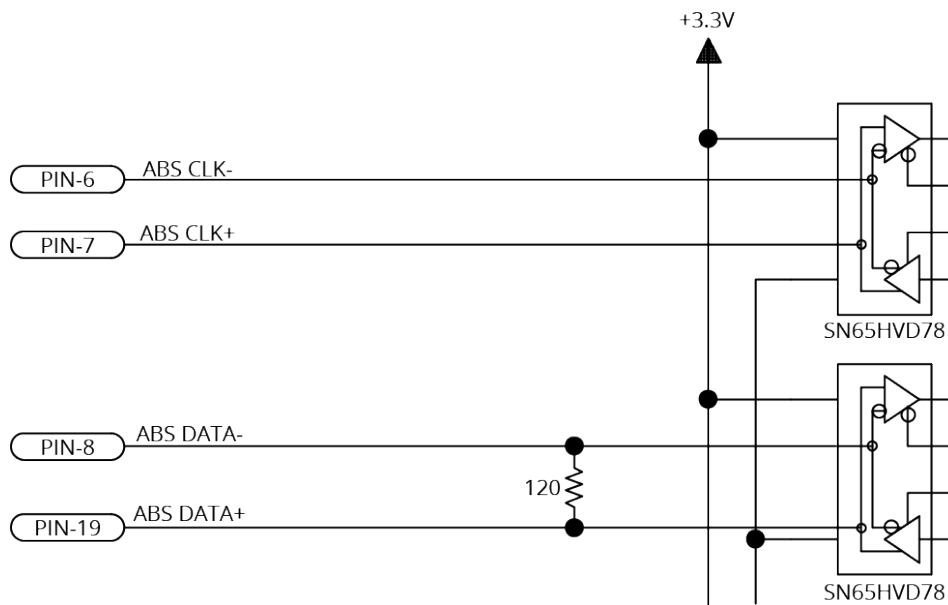

2.3.1.3. Sine Wave Encoder (Primary) [-MX2/-MX3 Option]

The Sine Wave Encoder option provides higher positioning resolution by subdividing the fundamental output period of the encoder into smaller increments. The amount of subdivision is specified by the PrimaryEncoderMultiplicationFactor [A3200: EncoderMultiplicationFactor] parameter. Use Encoder Tuning [A3200: Feedback Tuning] to adjust the value of the gain, offset, and phase balance controller parameters to get the best performance. For more information, refer to the Help file.

High resolution or high-speed encoders can require increased bandwidth for correct operation. Use the High Speed Mode of the PrimaryEncoderMultiplierSetup [A3200: EncoderMultiplierSetup] parameter to enable the high bandwidth mode. Because this mode increases sensitivity to system noise, use it only if necessary.

The drive can generate emulated encoder signals. These signals can be output on the Auxiliary Encoder (AUX) connector, SYNC port connector, or used internally by the PSO. Refer to the EncoderDivider and PrimaryEmulatedQuadratureDivider [A3200: EmulatedQuadratureDivider] parameters and the encoder output functions [A3200: ENCODER OUT command] in the Help file for more information.

For the highest performance, use twisted pair double-shielded cable with the inner shield connected to signal common and the outer shield connected to frame ground. Do not join the inner and outer shields in the cable.

Table 2-19: Sine Wave Encoder Specifications

Specification	Value	
	Primary	Auxiliary
Input Frequency (max)	450 kHz, 2 MHz	450 kHz
Input Amplitude ⁽¹⁾	0.6 to 1.75 Vpk-pk	
Interpolation Factor (max)	-MX2	65,536
	-MX3	65,536
-MX2/-MX3 Primary Encoder Channel Interpolation Latency	800 nsec (analog input to quadrature output)	
Input Common Mode	1.5 to 3.5 VDC	
⁽¹⁾ Measured as SIN(+) - SIN(-) or COS(+) - COS(-)		

Figure 2-22: Sine Wave Encoder Phasing Reference Diagram

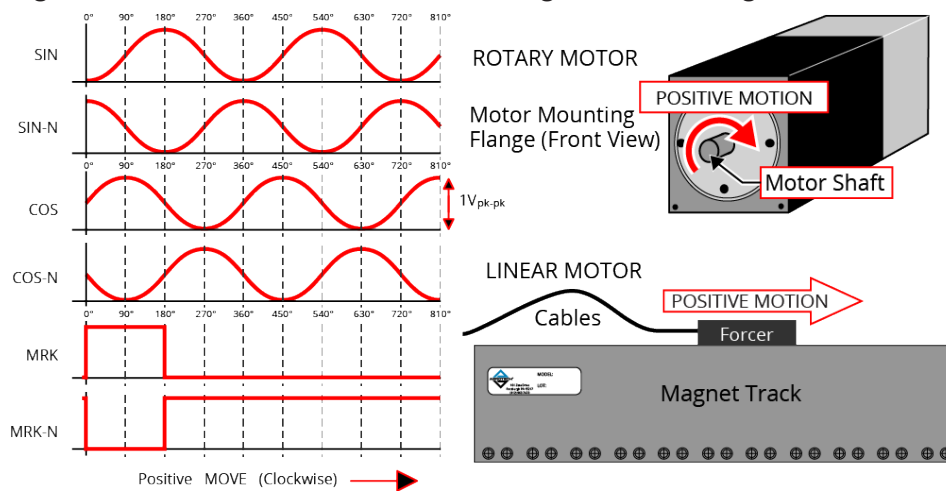
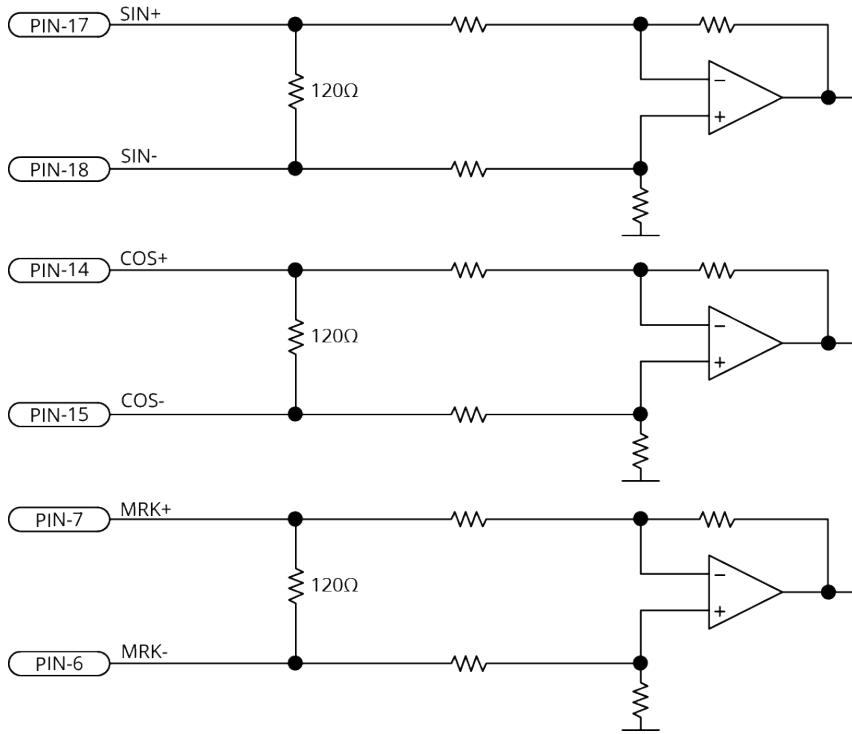

Figure 2-23: Sine Wave Encoder Schematic (Feedback Connector)



2.3.1.4. Encoder Phasing

Incorrect encoder polarity will cause the system to fault when enabled or when a move command is issued. [Figure 2-24](#) illustrates the proper encoder phasing for clockwise motor rotation (or positive forcer movement for linear motors). To verify, move the motor by hand in the CW (positive) direction while observing the position of the encoder in the diagnostics display (see [Figure 2-25](#)).

For dual loop systems, the velocity feedback encoder is displayed in the diagnostic display ([Figure 2-25](#)).

Figure 2-24: Encoder Phasing Reference Diagram (Standard)

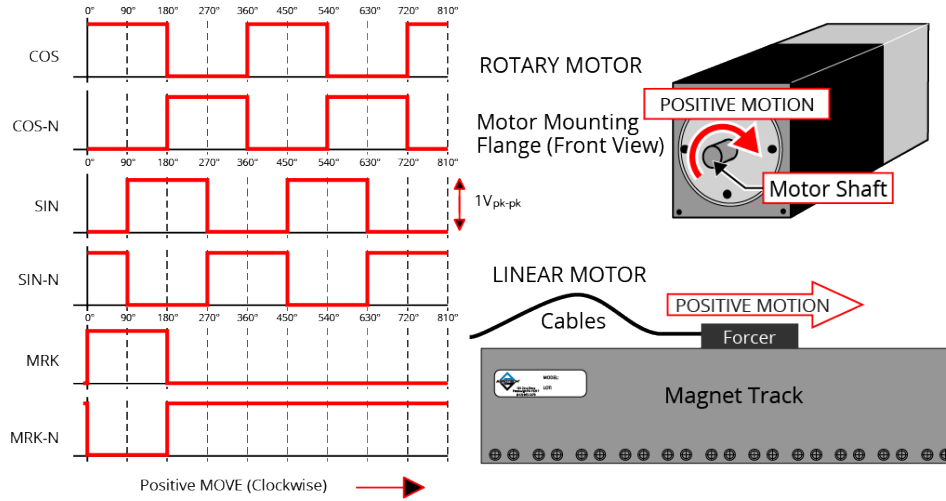

IMPORTANT: Encoder manufacturers may refer to the encoder signals as A, B, and Z. The proper phase relationship between signals is shown in [Figure 2-24](#).

Figure 2-25: Position Feedback in the Diagnostic Display

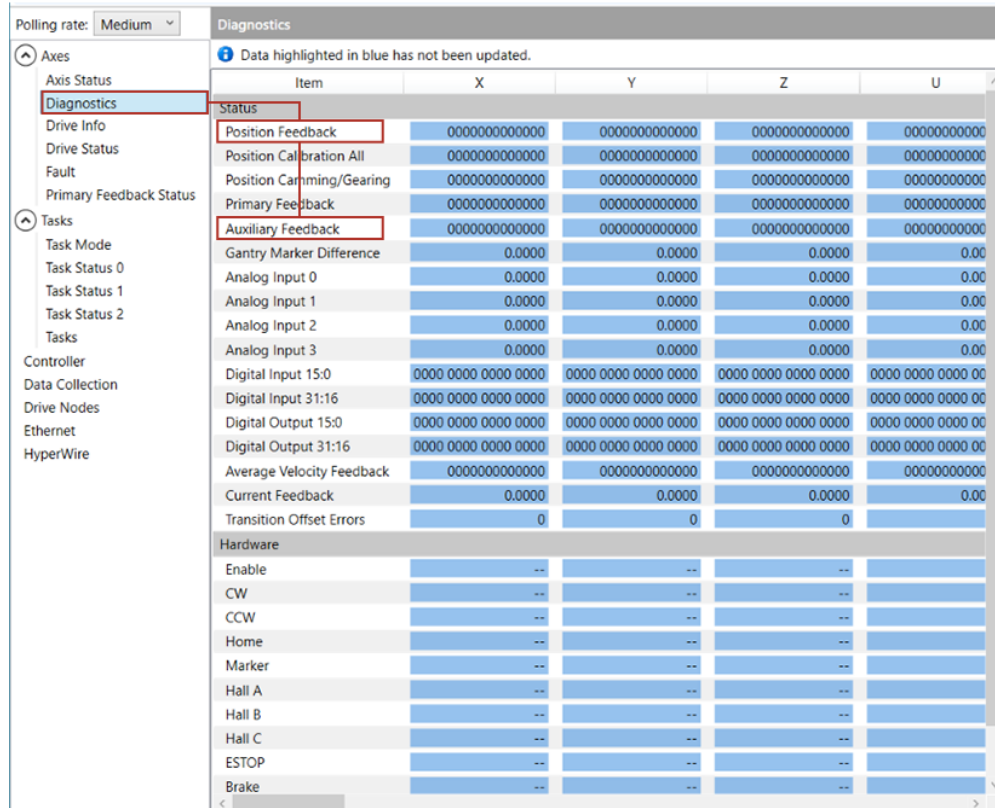

2.3.2. Hall-Effect Inputs

The Hall-effect switch inputs are recommended for AC brushless motor commutation but not absolutely required. The Hall-effect inputs accept 5 VDC level signals. Hall states (0,0,0) or (1,1,1) are invalid and will generate a "Hall Fault" axis fault.

Refer to [Section 2.2.1.1](#) for Hall-effect device phasing.

Table 2-20: Hall-Effect Feedback Pins on the Feedback Connector

Pin #	Description	In/Out/Bit
3	+5V Power ⁽¹⁾	Output
5	Hall-Effect Sensor B (brushless motors only)	Input
10	Hall-Effect Sensor A (brushless motors only)	Input
11	Hall-Effect Sensor C (brushless motors only)	Input
16	+5V Power ⁽¹⁾	Output
20	Signal Common	Output
21	Signal Common	Output

(1) The maximum combined current output is 500 mA.

Figure 2-26: Hall-Effect Inputs Schematic (Feedback Connector)

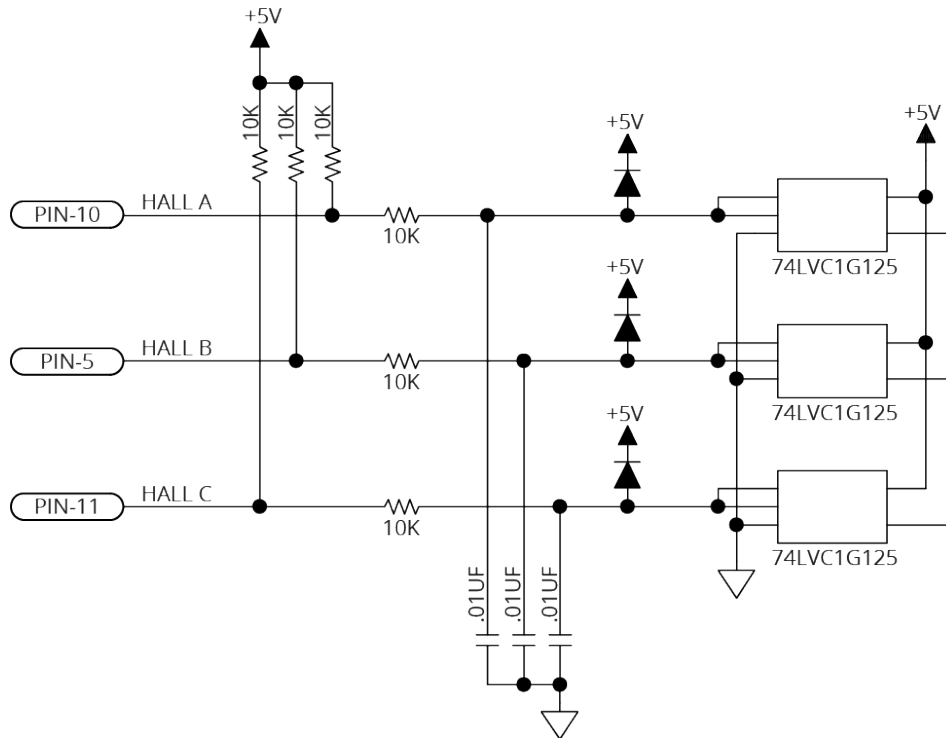

2.3.3. Thermistor Input

The thermistor input is used to detect a motor over temperature condition by using a positive temperature coefficient sensor. As the temperature of the sensor increases, so does the resistance. Under normal operating conditions, the resistance of the thermistor is low which will result in a low input signal. As the increasing temperature causes the resistance of the thermistor to increase, the sensor will trigger an over temperature fault.

The thermistor is connected between Pin 2 and Signal Common. The nominal trip value of the sensor is 1.385 k Ω . The circuit includes a 12 k Ω internal pull-up resistor which corresponds to a trip voltage of +0.52 V.

Table 2-21: Thermistor Input Pin on the Feedback Connector

Pin #	Description	In/Out/BI
2	Motor Over Temperature Thermistor	Input

Figure 2-27: Thermistor Input Schematic (Feedback Connector)

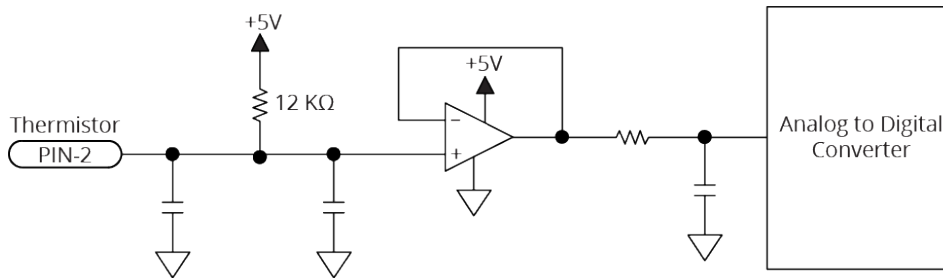

2.3.4. Encoder Fault Input

The encoder fault input is for use with encoders that have a fault output. This is provided by some manufacturers and indicates a loss of encoder function. The active state of this input is parameter configurable and the controller should be configured to disable the axis when the fault level is active.

The nominal trip voltage of the encoder fault input is +2.5 V.

Table 2-22: Encoder Fault Input Pin on the Feedback Connector

Pin #	Description	In/Out/Bi
23	Encoder Fault Input	Input

Figure 2-28: Encoder Fault Input Schematic (Feedback Connector)

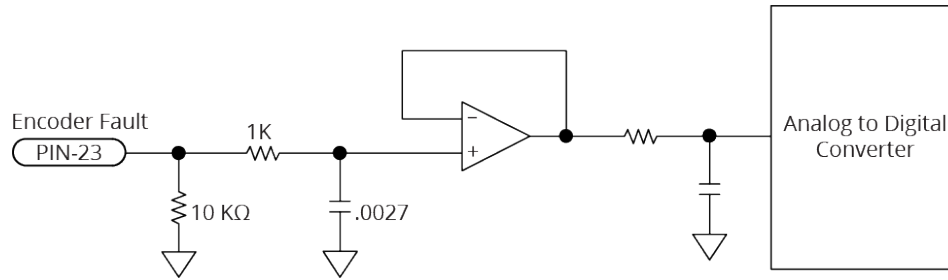

2.3.5. End of Travel and Home Limit Inputs

End of Travel (EOT) limits are required to define the end of the physical travel on linear axes. Positive or clockwise motion is stopped by the clockwise (CW) end of travel limit input. Negative or counterclockwise motion is stopped by the counterclockwise (CCW) end of travel limit input. The Home Limit switch can be parameter configured for use during the home cycle, however, the CW or CCW EOT limit is typically used instead. All of the end-of-travel limit inputs accept 0-24 VDC level signals. Limit directions are relative to the encoder polarity in the diagnostics display (refer to [Figure 2-31](#)).

Table 2-23: End of Travel and Home Limit Pins on the Feedback Connector

Pin #	Description	In/Out/Bi
12	Clockwise End of Travel Limit	Input
16	+5V Power ⁽¹⁾	Output
20	Signal Common	Output
21	Signal Common	Output
22	Home Switch Input	Input
24	Counterclockwise End of Travel Limit	Input

(1) The maximum combined current output is 500 mA.

The active state (High/Low) of the EOT limits is software selectable (by the EndOfTravelLimitSetup axis parameter). [Figure 2-29](#) shows the possible wiring configurations for normally-open and normally-closed switches and the parameter setting to use for each configuration.



IMPORTANT: Use NPN-type normally-closed limit switches (Active High) to provide fail-safe behavior in the event of an open circuit.

Figure 2-29: End of Travel and Home Limit Input Connections

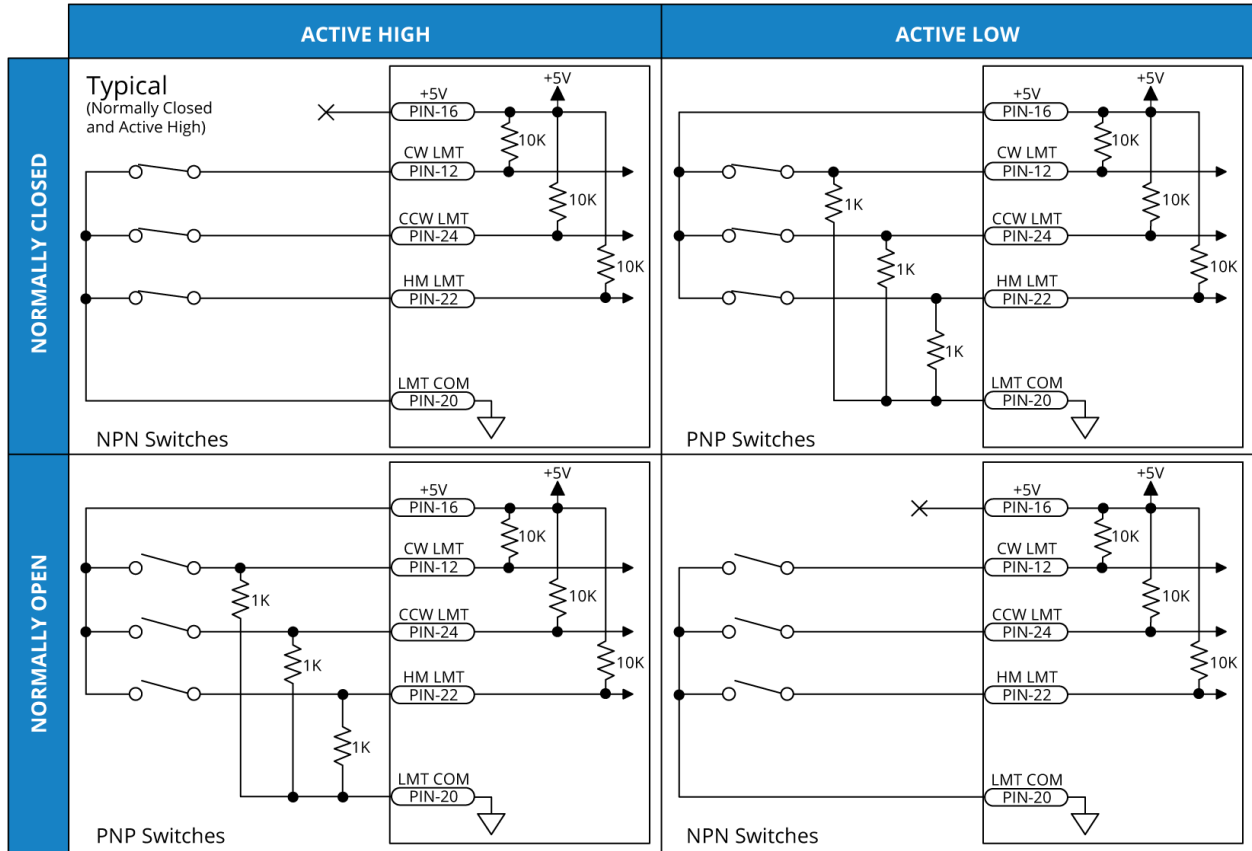
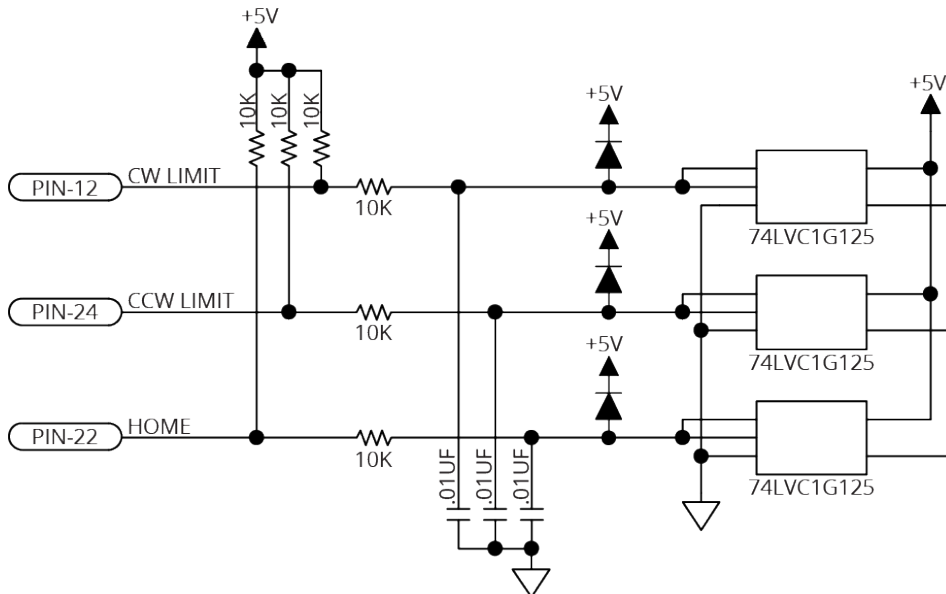

Figure 2-30: End of Travel and Home Limit Input Schematic (Feedback Connector)



2.3.5.1. End of Travel and Home Limit Phasing

If the EOT limits are reversed, you will be able to move further into a limit but be unable to move out. To correct this, swap the connections to the CW and CCW inputs at the Feedback connector or swap the CW and CCW limit functionality in the software using the EndOfTravelLimitSetup parameter. View the logic level of the EOT limit inputs in the Diagnostics display (shown in [Figure 2-31](#)).

Figure 2-31: End of Travel and Home Limit Input Diagnostic Display

Poling rate: Medium

Diagnostics

Data highlighted in blue has not been updated.

Item	X	Y	Z	U
Status				
Position Feedback	000000000000	000000000000	000000000000	000000000000
Position Calibration All	000000000000	000000000000	000000000000	000000000000
Position Camming/Gearing	000000000000	000000000000	000000000000	000000000000
Primary Feedback	000000000000	000000000000	000000000000	000000000000
Auxiliary Feedback	000000000000	000000000000	000000000000	000000000000
Gantry Marker Difference	0.0000	0.0000	0.0000	0.00
Analog Input 0	0.0000	0.0000	0.0000	0.00
Analog Input 1	0.0000	0.0000	0.0000	0.00
Analog Input 2	0.0000	0.0000	0.0000	0.00
Analog Input 3	0.0000	0.0000	0.0000	0.00
Digital Input 15:0	0000 0000 0000 0000	0000 0000 0000 0000	0000 0000 0000 0000	0000 0000 0000 00
Digital Input 31:16	0000 0000 0000 0000	0000 0000 0000 0000	0000 0000 0000 0000	0000 0000 0000 00
Digital Output 15:0	0000 0000 0000 0000	0000 0000 0000 0000	0000 0000 0000 0000	0000 0000 0000 00
Digital Output 31:16	0000 0000 0000 0000	0000 0000 0000 0000	0000 0000 0000 0000	0000 0000 0000 00
Average Velocity Feedback	000000000000	000000000000	000000000000	000000000000
Current Feedback	0.0000	0.0000	0.0000	0.00
Transition Offset Errors	0	0	0	
Hardware				
Enable	--	--	--	--
CW	--	--	--	--
CCW	--	--	--	--
Home	--	--	--	--
Marker	--	--	--	--
Hall A	--	--	--	--
Hall B	--	--	--	--
Hall C	--	--	--	--
ESTOP	--	--	--	--
Brake	--	--	--	--

2.3.6. Brake Outputs

The drive has a dedicated brake control circuit. Configure the brake with the BrakeSetup [A3200: EnableBrakeControl] parameter for automatic control (typical). You can also use software commands to directly control the brake output.

Refer to [Section 2.6](#) for more information on powering the brake circuit.

Table 2-24: Brake Output Pins on the Feedback Connector

Pin #	Description	In/Out/Bit
13	Brake Output -	Output
25	Brake Output +	Output

Table 2-25: Brake Control Specifications

Specification	Value
Maximum Voltage	24 VDC
Maximum Current	1 A

A varistor must be connected across the brake to minimize voltage transients.

Figure 2-32: Brake Connected to the 25-Pin Feedback Connector (Typical)

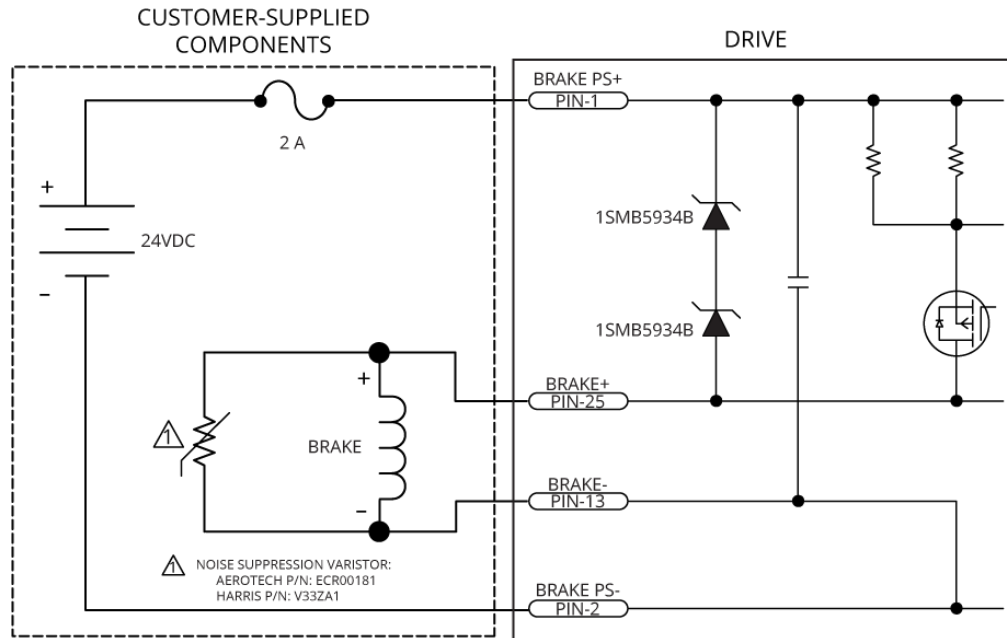

2.4. Safe Torque Off Input (STO)

The STO circuit is comprised of two identical channels, each of which must be energized in order for the drive to produce motion. Each STO input is opto-isolated and accepts 24 V levels directly without the need for external current limiting resistors.



IMPORTANT: The drive might be equipped with an STO bypass circuit board. The bypass circuit board defeats the STO safety circuit and allows the system to run at all times. To use the STO safety functionality, remove the circuit board and make connections as outlined in this section. Refer to [Installation Overview](#) on [Page 16](#) for the location of the STO bypass plug.



IMPORTANT: The application circuit and its suitability for the desired safety level is the sole responsibility of the user of the drive.



WARNING: STO wires must be insulated to prevent short circuits between connector pins. The primary concern is a short circuit between STO 1 IN and STO 2 IN wire strands.

Table 2-26: STO Connector Pinout

Pin #	Signal	Description	In/Out/Bi	Connector
1	Power Supply +	Use only to defeat STO by connecting to STO 1 IN and STO 2 IN. Not for customer use.	Output	
2	STO 1 IN	STO Channel 1 Positive Input	Input	
3	RETURN	STO Negative Input	Input	
4	STO 2 IN	STO Channel 2 Positive Input	Input	
5	Power Supply -	Use only to defeat STO by connecting to RETURN. Not for customer use.	Output	

Table 2-27: STO Mating Connector Ratings

Specification		Description
Type		5-Pin Terminal Block
Part Numbers		Aerotech: ECK02393 Phoenix: 1827622
Conductor Cross Section	One conductor, stranded with ferrule and plastic sleeve	18...22 AWG (0.25...0.75 mm ²)
	Two conductors (same cross-section), stranded, twin ferrule with plastic sleeve	20 AWG (0.5 mm ²)
Tightening Torque		0.22...0.25 N·m
Conductor Insulation Strip Length		7 mm (0.25 in)
(1) Refer to the manufacturer website for additional information.		

Table 2-28: STO Electrical Specifications

Status	Value
STO off (motion allowed)	18-24 V, 7 ma
STO on (safe state entered, no motion)	0-6 V
Recommended Wire Gauge	22-26 AWG (0.5 - 0.14 mm ²)
STO System Power Supply	PELV
STO Wire Length (maximum)	50 m

Figure 2-33 shows one safety device connected to multiple drives in parallel.



WARNING: The drive does not check for short circuits on the external STO wiring. If this is not done by the external safety device, short circuits on the wiring must be excluded. Refer to EN ISO 13849-2. For Category 4 systems, the exclusion of short circuits is mandatory.

Figure 2-33: Typical STO Configuration

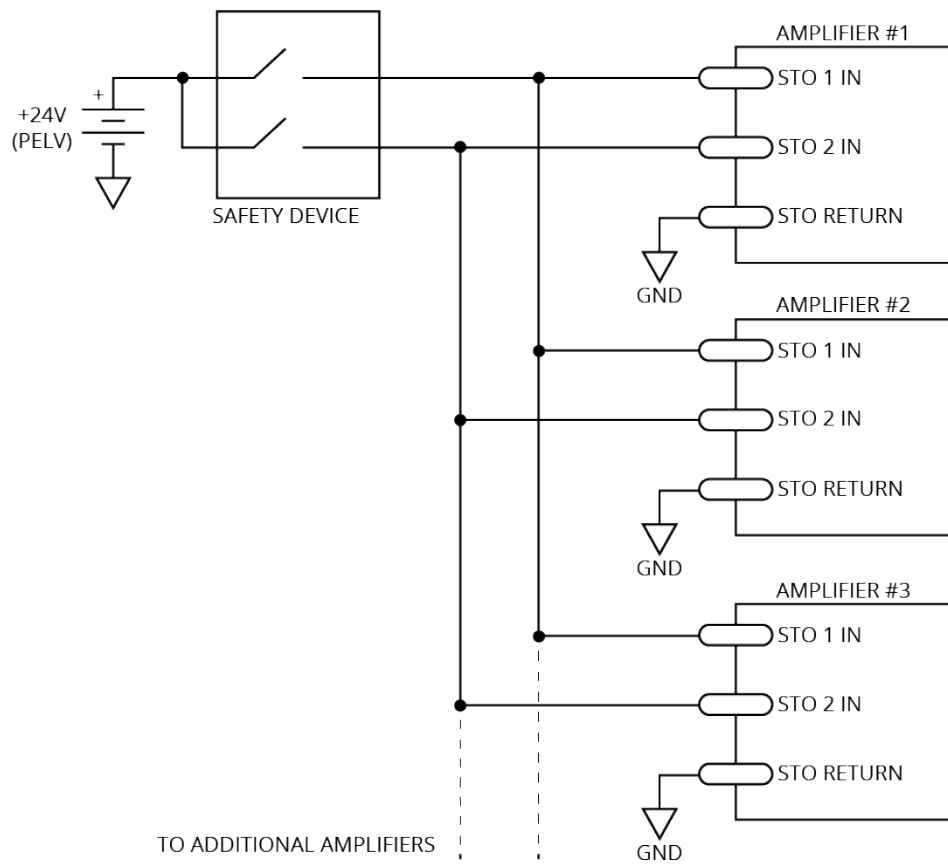

2.4.1. STO Standards

Table 2-29 describes and specifies the safety requirements at the system level for the Safe Torque Off (STO) feature of the drive. This assumes that diagnostic testing is performed according to Section 2.4.4. and Table 2-30.

Table 2-29: STO Standards

Standard	Maximum Achievable Safety
EN/IEC 61800-5- 2:2016	SIL 3
EN/IEC 61508-1:2010	SIL 3
EN/IEC 61508-2:2010	SIL 3
EN ISO 13849-1:2015	Category 4, PL e
EN/IEC 62061:2005 with Amendments	SIL 3

Table 2-30: STO Standards Data

Standard	Value
EN ISO 13849-1:2015	MTTF _D > 1000 years, DC _{AVG} 99% Maximum PL e, Category 4
EN ISO 13849-1:2015 EN/IEC 61508	Lifetime = 20 years No proof test required Interval for manual STO test: <ul style="list-style-type: none"> • Once per year for SIL2/PL d/category 3 • Once per three months for SIL3/PL e/category 3 • Once per day for SIL3/PL e/category 4
EN/IEC 61508	SIL3 PFH < 3 FIT SFF > 99%

2.4.2. STO Functional Description

The motor can only be activated when voltage is applied to both STO 1 and STO 2 inputs. The STO state will be entered if power is removed from either the STO 1 or the STO 2 inputs. When the STO state is entered, the motor cannot generate torque or force and is therefore considered safe. Both STO channels must be driven at the same time. If they are not driven at the same time, a diagnostic test failure will occur (refer to [STO Diagnostics](#)).

The STO function is implemented with two redundant channels in order to meet stated performance and SIL levels. STO 1 disconnects the high side power amplifier transistors and STO 2 disconnects the low side power amplifier transistors. Disconnecting either set of transistors effectively prevents the drive from being able to produce motion.

The drive software monitors each STO channel and will generate an Emergency Stop software fault when either channel signals the stop state. Each STO channel contains a fixed delay which allows the drive to perform a controlled stop before the power amplifier transistors are turned off.

A typical configuration requiring a controlled stop has the Emergency Stop Fault mask bit set in the FaultMask, FaultMaskDecel, and FaultMaskDisable parameters. This stops the axis using the rate specified by the AbortDecelRate parameter. The software will disable the axis as soon as the deceleration ramp is complete. This is typically configured to occur before the STO channel turns off the power amplifier transistors.

The software-controlled stop functionality must be excluded when considering overall system safety. This is because the software is not safety rated and cannot be included as part of the safety function.

The software-controlled stop function can ignore short diagnostic pulses on the STO 1+ and STO 2+ inputs. The parameter "STOPulseFilter" specifies the maximum pulse width that the software will ignore. The filter parameter does not affect the operation of STO hardware channels.

To resume normal operation, apply power to both STO 1 and STO 2 inputs and use the *Acknowledge All* button or the AcknowledgeAll() or FaultAcknowledge() function to clear the Emergency Stop software fault. The recommended use of the Emergency Stop Fault fault mask bits prevent the system from automatically restarting.

You can achieve longer delay times through the use of an external delay timer, such as the Omron G9SA-321 Safety Relay Unit. Place this device between the system ESTOP wiring and the drive's STO inputs. Connect the ESTOP signal directly to a digital input, in addition to the external timer, to allow the drive to begin a software-controlled stop as soon as the ESTOP signal becomes active. Use the EmergencyStopFaultInput [A3200: ESTOPFaultInput] parameter to configure a digital input as an ESTOP input.

The STO feature can only be used with AC or stepper motor types. It is not certified to prevent hazardous motion when using DC brush motor types.

Non-standard STO delay times are provided by special factory order. In this case, the non-standard STO delay time is indicated by a label placed on the slice amplifier's main connector (STO DELAY = xx sec).

Table 2-31: STO Signal Delay

	Value
STO Time Delay	450-550 msec

Table 2-32: Motor Function Relative to STO Input State

STO 1	STO 2	Motor Function
Unpowered	Unpowered	No force/torque
Unpowered ⁽¹⁾	Powered ⁽¹⁾	No force/torque
Powered ⁽¹⁾	Unpowered ⁽¹⁾	No force/torque
Powered	Powered	Normal Operation

1. This is considered a Fault Condition since STO 1 and STO 2 do not match. Refer to [Section 2.4.4](#).

2.4.3. STO Startup Validation Testing

Verify the state of the STO 1 and STO 2 channels by manually activating the external STO hardware. Each STO channel must be tested separately in order to detect potential short circuits between the channels. The current state of the STO 1 and STO 2 inputs is shown in the Status Utility. A “–” indicates that the STO input is powered by a high voltage level (24 V). An “ON” indicates that the voltage source has been removed from the input (open circuit or 0 V), and that the STO channel is in the safe state.



DANGER: The STO circuit does not remove lethal voltage from the motor terminals. AC mains power must be removed before servicing.

2.4.4. STO Diagnostics

Activation of STO means removing power from the drive STO inputs. This is typically done by pressing the emergency stop switch. The drive initiates a diagnostic check every time the STO is activated after the Diagnostic Test Delay Time has elapsed. The diagnostic check verifies that each channel has entered the safe state. The drive is held in the safe state if it determines that one of the channels has not properly entered the safe state. An open circuit or short to 24 V in either STO channel will result in this condition (refer to [Section 2.4.3.](#)). The Status Utility screen can be used to verify the levels of the STO input signals while troubleshooting. The safe state is cleared when both STO channels are cycled with matching signal levels such that the diagnostic test completes successfully.

The drive is held in the safe state if it determines that one of the channels has not properly entered the safe state. In this case, the `stoCrossCheckFault` bit will be set and can be viewed in the **STO Status** status item. A **Position Error Fault** or **Emergency Stop Fault** will occur if motion is attempted while in this state. The drive will remain in the safe state until STO is reactivated with both channels in a safe state such that the diagnostics test completes successfully.

An open circuit or short to 24 V in either STO channel or a timing difference between the channels will result in a diagnostic test failure (refer to [STO Startup Validation Testing](#)). The Status Utility screen or **STO Status** status item can be used to verify the levels of the STO input signals while troubleshooting.

In order to pass internal testing, the STO circuit must be activated (power removed from both inputs) according to the interval specified in [Table 2-30](#).

Table 2-33: STO Timing

Time	Description	Value
T1	STO Delay Time (STO input active to motor power off)	450-550 msec
T2	STO deactivated to motor power on (the software is typically configured so that the motor does not automatically re-energize).	< 1 msec
T3	Diagnostic Test Delay Time	550-610 msec

Figure 2-34: STO Timing

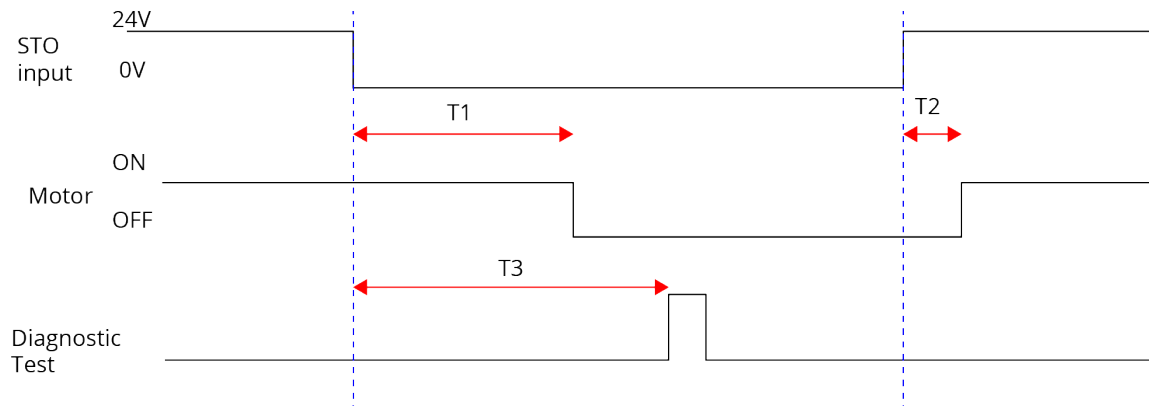

The software is typically configured to execute a controlled stop when the STO state is first detected. If power is reapplied to the STO inputs before the STO Delay Time, an STO hardware shutdown will not occur but a software stop may, depending on the width of the STO pulse. The controller will ignore STO active pulses shorter in length than the `STOPulseFilter` parameter setting.

2.5. Auxiliary I/O Connector

The Auxiliary I/O connector has 1 analog input, 6 digital inputs, 1 analog output, 4 digital outputs, a secondary line driver encoder input, and a secondary absolute encoder interface.

Table 2-34: Auxiliary I/O Connector Pinout

Pin#	Description	In/Out/Bi	Connector
1	Auxiliary Sine +	Bidirectional	
	Absolute Encoder Data +	Bidirectional	
2	Auxiliary Sine -	Bidirectional	
	Absolute Encoder Data -	Bidirectional	
3	High-Speed Input 20 + / PSO External Sync. +	Input	
4	High-Speed Input 20 - / PSO External Sync. -	Input	
5	High-Speed Input 21 +	Input	
6	High-Speed Input 21 -	Input	
7	Digital Output 0	Output	
8	Digital Output 1	Output	
9	Digital Output 2	Output	
10	Auxiliary Cosine +	Bidirectional	
	Absolute Encoder Clock +	Output	
11	Auxiliary Cosine-	Bidirectional	
	Absolute Encoder Clock -	Output	
12	+5 V (500 mA max)	Output	
13	Analog Input 0+ (Differential)	Input	
14	Analog Input 0- (Differential)	Input	
15	Digital Output Common	Output	
16	Digital Output 3	Output	
17	Digital Input 0 / CCW EOT Input ⁽¹⁾	Input	
18	Digital Input 1 / CW EOT Input ⁽¹⁾	Input	
19	Auxiliary Marker - / PSO ⁽²⁾ Differential Output - / PSO TTL Output	Bidirectional	
20	Auxiliary Marker + / PSO ⁽²⁾ Differential Output +	Bidirectional	
21	Common	Output	
22	Analog Output 0	Output	
23	Analog Common	Output	
24	Digital Input Common	Output	
25	Digital Input 2 / Home Input ⁽¹⁾	Input	
26	Digital Input 3	Input	

(1) Software configured option
(2) For PSO, refer to [Section 2.5.2](#).

Table 2-35: Auxiliary I/O Mating Connector Ratings

Specification	26-Pin Solder Cup	Backshell
Aerotech Part Number	ECK01259	ECK01022
Manufacturer Part Number ⁽¹⁾	Kycon K86-AA-26P	Amphenol 17E-1725-2
Maximum Wire Size	22 AWG (0.25 mm ²)	N/A

(1) Refer to the manufacturer website for additional information.

2.5.1. Auxiliary Encoder Interface

The Auxiliary Encoder connector gives you a second encoder channel. This channel is typically used for dual loop applications.

Use the AuxiliaryFeedbackType [A3200: PositionFeedbackType or VelocityFeedbackType] parameter to configure the drive to accept an encoder signal type.

Square Wave encoder signals: [Section 2.5.1.1.](#)

Absolute encoder signals: [Section 2.5.1.2.](#)

Sine Wave encoder signals (with the -MX3 option): [Section 2.5.1.3.](#)

You can configure the Auxiliary Encoder interface as an output that will transmit encoder signals for external use. Use the DriveEncoderOutputConfigureInput() function [A3200: EncoderDivider parameter] to configure the Sine \pm and Cosine \pm connector pins as RS-422 outputs. You can only echo incremental square wave primary encoder inputs or, with the -MX2 or -MX3 option, incremental sine wave primary encoder inputs. You cannot use the absolute encoder interface when you echo incremental signals.

Table 2-36: Auxiliary Encoder Pins on the Auxiliary I/O Connector

Pin#	Description	In/Out/Bi
1	Auxiliary Sine +	Bidirectional
	Absolute Encoder Data +	Bidirectional
2	Auxiliary Sine -	Bidirectional
	Absolute Encoder Data -	Bidirectional
10	Auxiliary Cosine +	Bidirectional
	Absolute Encoder Clock +	Output
11	Auxiliary Cosine-	Bidirectional
	Absolute Encoder Clock -	Output
12	+5 V (500 mA max)	Output
19	Auxiliary Marker - / PSO ⁽²⁾ Differential Output - / PSO TTL Output	Bidirectional
20	Auxiliary Marker + / PSO ⁽²⁾ Differential Output +	Bidirectional
21	Common	Output

(2) For PSO, refer to [Section 2.5.2.](#)

2.5.1.1. Square Wave Encoder (Auxiliary)

The drive accepts RS-422 square wave encoder signals. The drive will generate a feedback fault if it detects an invalid signal state caused by an open or shorted signal connection. Use twisted-pair wiring for the highest performance and noise immunity.

Table 2-37: Square Wave Encoder Specifications

Specification	Value
Encoder Frequency	10 MHz maximum (25 ns minimum edge separation)
x4 Quadrature Decoding	40 million counts/sec

Figure 2-35: Square Wave Encoder Interface (Aux I/O Connector)

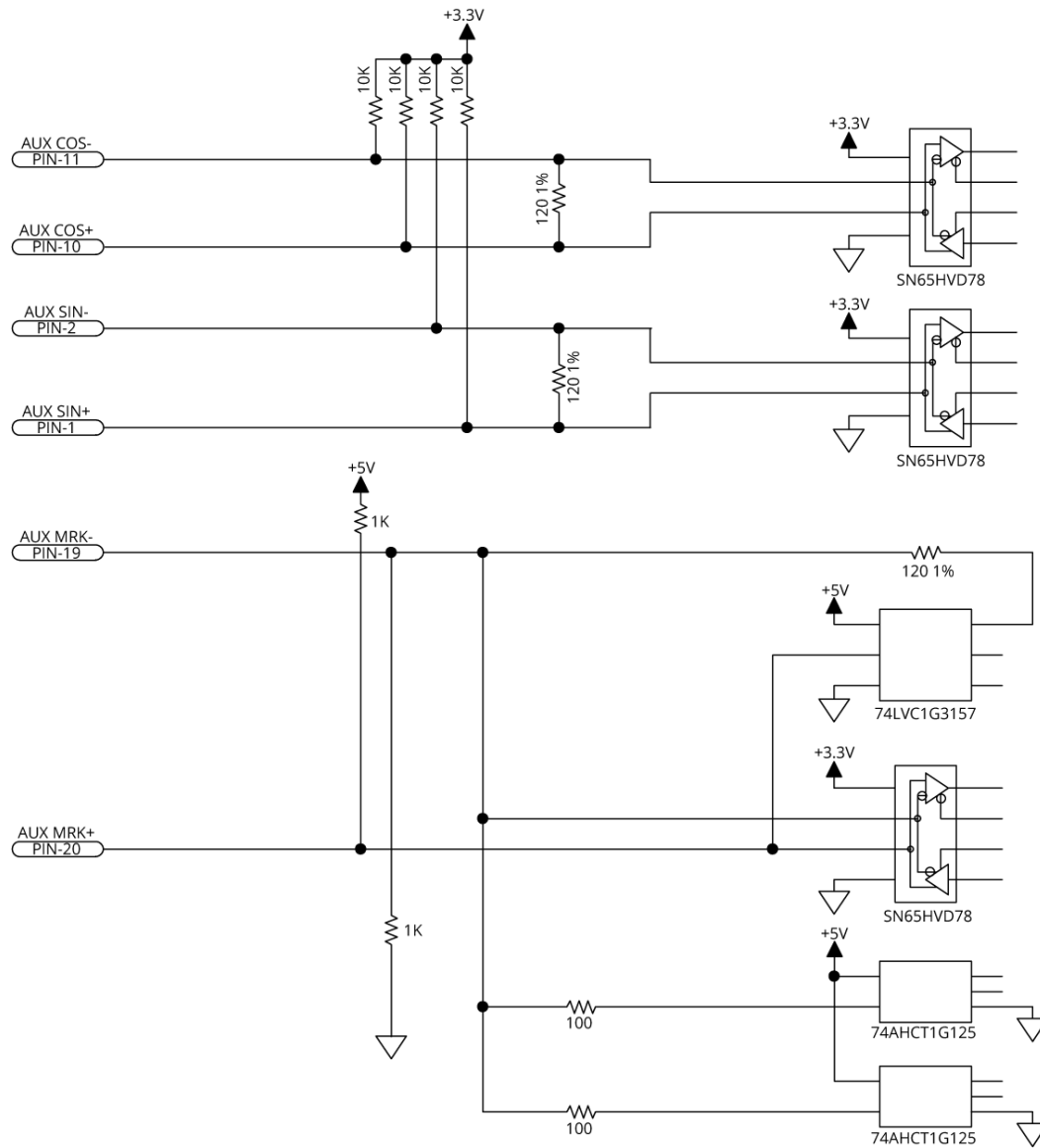

2.5.1.2. Absolute Encoder (Auxiliary)

The drive retrieves absolute position data along with encoder fault information through a serial data stream from the absolute encoder. Use twisted-pair wiring for the highest performance and noise immunity. You cannot use an absolute encoder with incremental signals on the Auxiliary I/O Connector.

Refer to [Figure 2-36](#) for the serial data stream interface.

Refer to the Help file for information on how to set up your EnDat, BiSS, or SSI absolute encoder parameters.

Table 2-38: Absolute Encoder Specifications

Specification	Value
Sampling Frequency	20 kHz
Maximum Reading Speed	Refer to your encoder data sheet.

Figure 2-36: Absolute Encoder Schematic (Auxiliary I/O Connector)

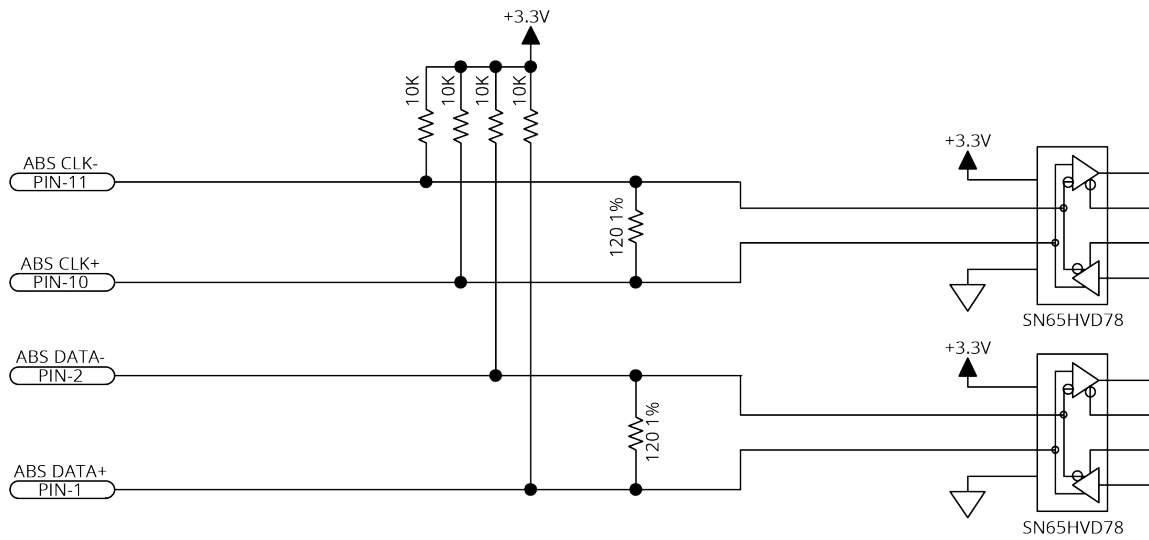

2.5.1.3. Sine Wave Encoder (Auxiliary) [-MX3 Option]

The Sine Wave Encoder option provides higher positioning resolution by subdividing the fundamental output period of the encoder into smaller increments. The amount of subdivision is specified by the AuxiliaryEncoderMultiplicationFactor parameter. Use Encoder Tuning [A3200: Feedback Tuning] to adjust the value of the gain, offset, and phase balance controller parameters to get the best performance. For more information, refer to the Help file.

You cannot use the sine wave encoder on the auxiliary connector with the -MX3 multiplier option as an input to the PSO. The -MX3 option does not generate emulated quadrature signals from the auxiliary connector.

For the highest performance, use twisted pair double-shielded cable with the inner shield connected to signal common and the outer shield connected to frame ground. Do not join the inner and outer shields in the cable.

Table 2-39: Sine Wave Encoder Specifications

Specification	Value	
	Primary	Auxiliary
Input Frequency (max)	450 kHz, 2 MHz	450 kHz
Input Amplitude ⁽¹⁾	0.6 to 1.75 Vpk-pk	
Interpolation Factor (max)	-MX2	65,536
	-MX3	65,536
-MX2/-MX3 Primary Encoder Channel Interpolation Latency	800 nsec (analog input to quadrature output)	
Input Common Mode	1.5 to 3.5 VDC	

(1) Measured as SIN(+) - SIN(-) or COS(+) - COS(-)

Figure 2-37: Sine Wave Encoder Phasing Reference Diagram

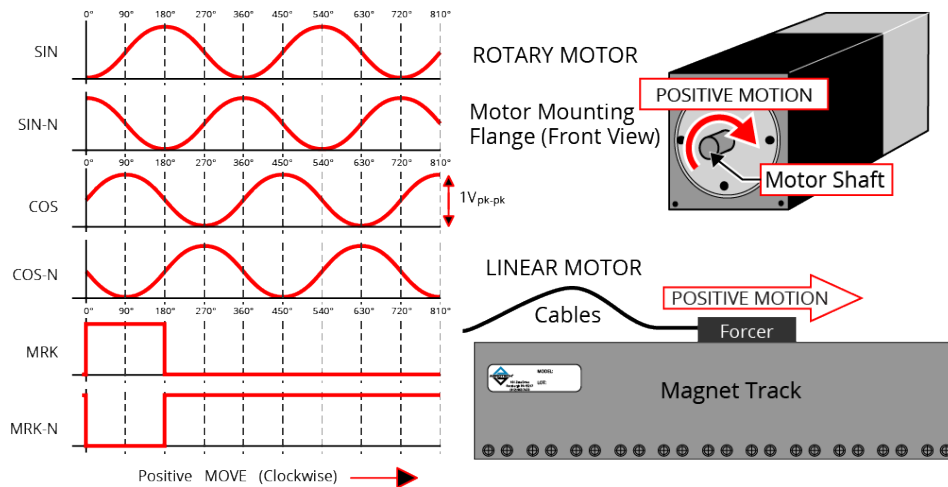
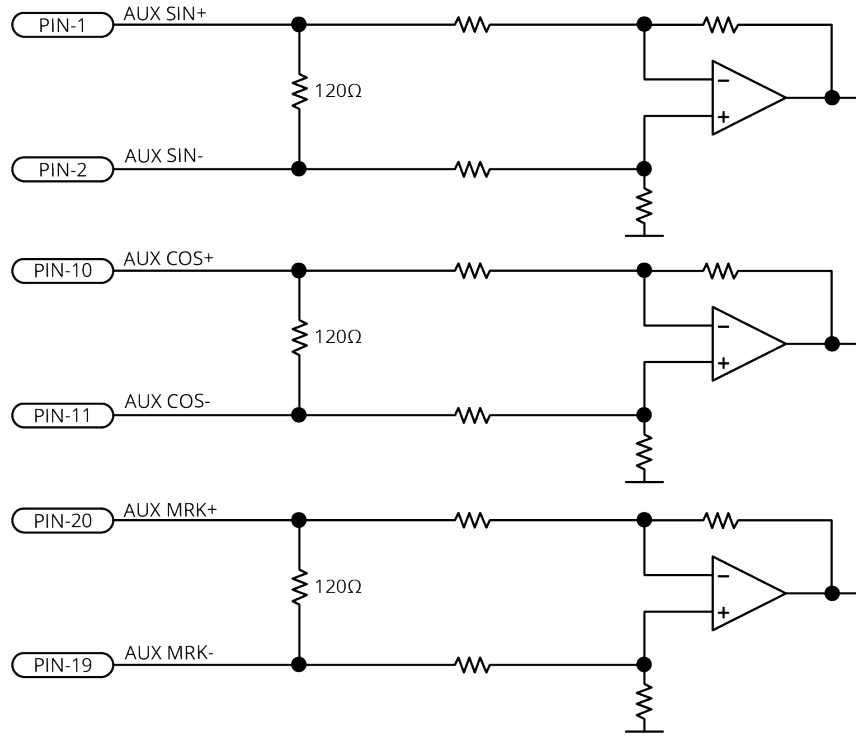

Figure 2-38: Sine Wave Encoder Schematic (Auxiliary I/O Connector)



2.5.2. Position Synchronized Output (PSO)

The PSO signal is available on the dual-function AUX Marker/PSO signal lines. Use the PSO pulse external sync functions [A3200: PSOOUTPUT PULSE EXTSYNC command] to configure the auxiliary marker as an output. Refer to the Help file for more information.

Use the PsoOutputConfigureOutput() function [A3200: PSOOUTPUT CONTROL command] to transmit the PSO output signal on the Marker \pm pins differentially. Or, use the PsoOutputConfigureOutput() function [A3200: PSOOUTPUT CONTROL command] to configure the Marker - pin as a 5V TTL PSO output.

When configured for differential use with pin 19 as PSO Differential Output - and pin 20 as PSO Differential Output +, the PSO output is active low. [Figure 2-39](#) shows how the output pins are biased so that the output is in the OFF state when it is not actively driven. If you want an active high output, you can change the pins so that pin 19 is the PSO Differential Output + and pin 20 is the PSO Differential Output -.

The differential signal format is recommended when using long cable lengths in noisy environments or when high frequency pulse transmission is required. It is best to locate the line receiver close to the receiving electronics. A 5 V TTL signal is used to drive an opto coupler or general purpose TTL input. This signal is active high and is driven to 5 V when a PSO fire event occurs. When the drive is reset or after initial power up, the PSO pins (refer to [Table 2-41](#)), are not actively driven and the fail safe state is defined by pull-up and pull-down resistors as shown in [Figure 2-39](#).

The -EB1 I/O option board has additional PSO signal formats. Refer to [Section 3.5](#) for more information.

Table 2-40: PSO Specifications

Specification		Value
Output	TTL	5 V, 16 mA (max)
Maximum PSO Output (Fire) Frequency	TTL	12.5 MHz
	RS-422	12.5 MHz
Output Latency [Fire event to output change]	TTL	25 ns
	RS-422	25 ns

Table 2-41: PSO Pins on the Auxiliary I/O Connector

Pin#	Description	In/Out/Bi
19	Auxiliary Marker - / PSO Differential Output - / PSO TTL Output	Bidirectional
20	Auxiliary Marker + / PSO Differential Output +	Bidirectional
21	Common	Output

Figure 2-39: PSO Interface
Differential

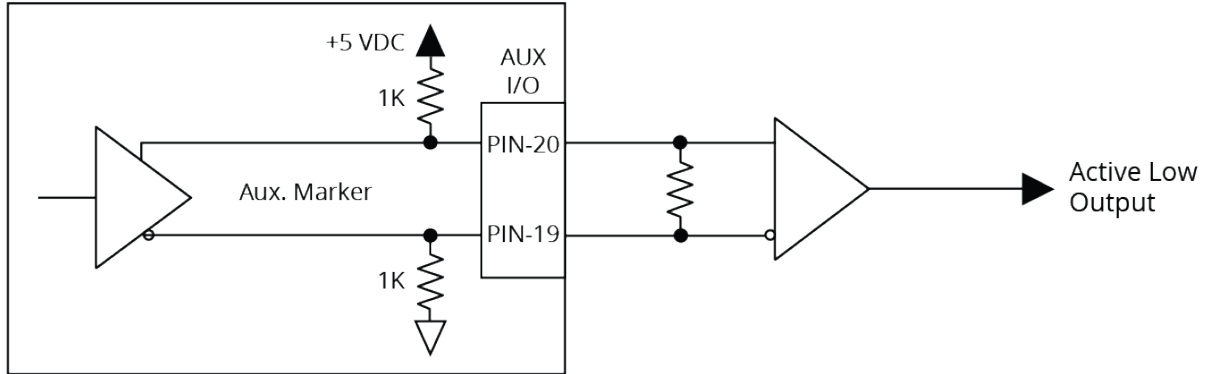

TTL

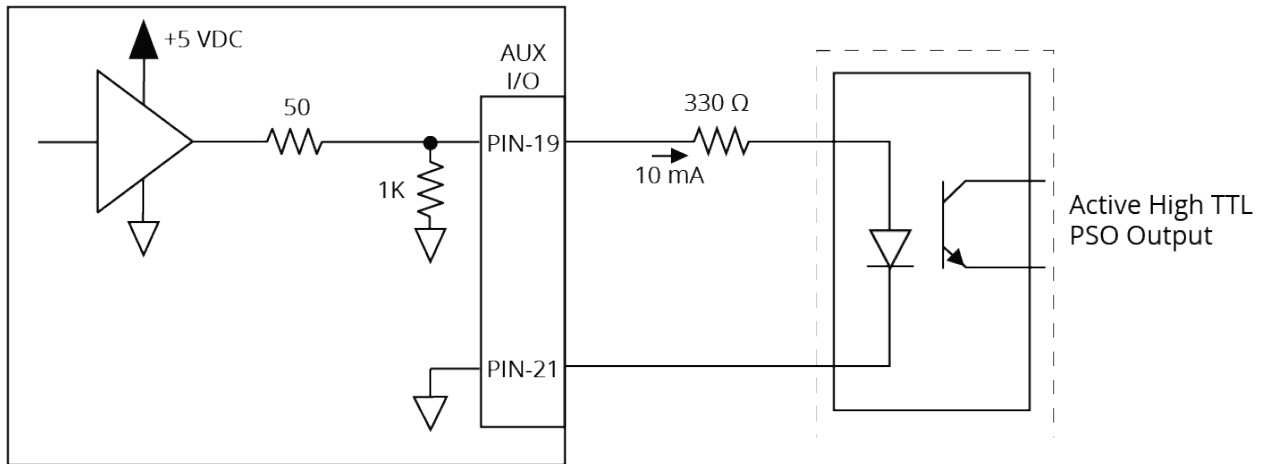

2.5.3. Digital Outputs

Optically-isolated solid-state relays drive the digital outputs. You can connect the digital outputs in current sourcing or current sinking mode but you must connect all four outputs in the same configuration. Refer to [Figure 2-41](#) and [Figure 2-42](#).

You must install suppression diodes on digital outputs that drive relays or other inductive devices. To see an example of a current sourcing output that has diode suppression, refer to [Figure 2-41](#). To see an example of a current sinking output that has diode suppression, refer to [Figure 2-42](#).

The digital outputs are not designed for high-voltage isolation applications and they should only be used with ground-referenced circuits.

The digital outputs have overload protection. They will resume normal operation when the overload is removed.

Table 2-42: Digital Output Specifications

Digital Output Specifications	Value
Maximum Voltage	24 V (26 V Maximum)
Maximum Sink/Source Current	250 mA/output
Output Saturation Voltage	0.9 V at maximum current
Output Resistance	3.7 Ω
Rise / Fall Time	250 μ s (2K pull up to 24V)
Reset State	Output Off (High Impedance State)

Table 2-43: Digital Output Pins on the Auxiliary I/O Connector

Pin#	Description	In/Out/Bi
7	Digital Output 0	Output
8	Digital Output 1	Output
9	Digital Output 2	Output
15	Digital Output Common	Output
16	Digital Output 3	Output

Figure 2-40: Digital Output Schematic (Aux I/O Connector)

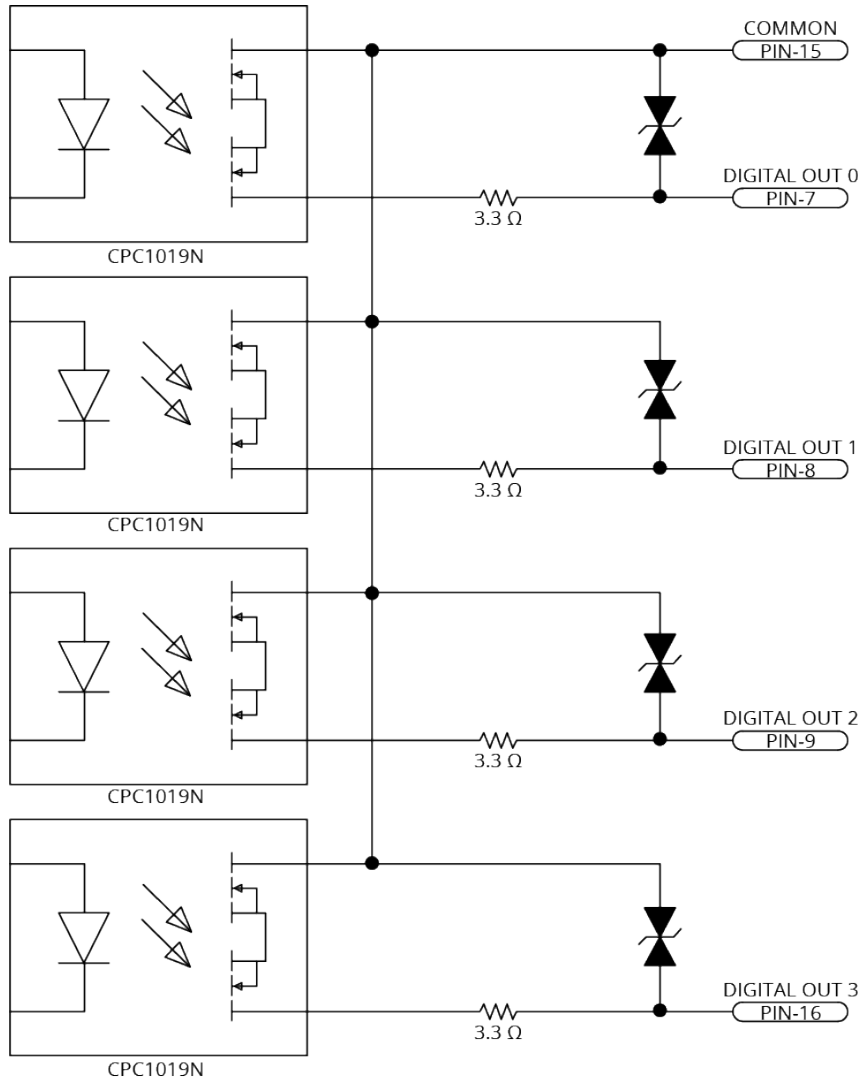
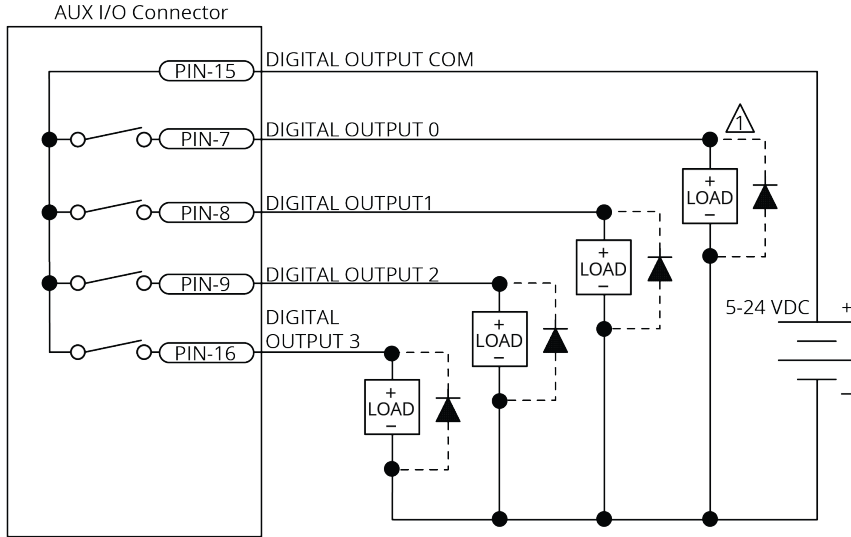
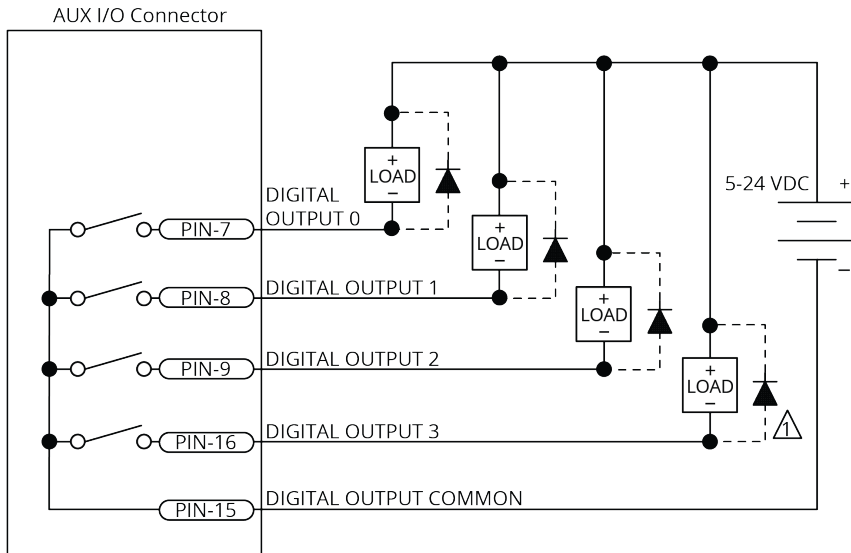

Figure 2-41: Digital Outputs Connected in Current Sourcing Mode



DIODE REQUIRED ON EACH OUTPUT THAT DRIVES AN INDUCTIVE DEVICE (COIL), SUCH AS A RELAY.

Figure 2-42: Digital Outputs Connected in Current Sinking Mode



DIODE REQUIRED ON EACH OUTPUT THAT DRIVES AN INDUCTIVE DEVICE (COIL), SUCH AS A RELAY.

2.5.4. Digital Inputs

You can connect the digital inputs to current sourcing or current sinking devices but you must connect all four inputs in the same configuration. Refer to [Figure 2-44](#) and [Figure 2-45](#). The digital inputs are not designed for high-voltage isolation applications. They should only be used with ground-referenced circuits.

Table 2-44: Digital Input Specifications

Input Voltage	Approximate Input Current	Turn On Time	Turn Off Time
+5 V to +24 V	6 mA	10 μ s	43 μ s

Table 2-45: Digital Input Pins on the Auxiliary I/O Connector

Pin#	Description	In/Out/Bi
17	Digital Input 0 / CCW EOT Input ⁽¹⁾	Input
18	Digital Input 1 / CW EOT Input ⁽¹⁾	Input
24	Digital Input Common	Output
25	Digital Input 2 / Home Input ⁽¹⁾	Input
26	Digital Input 3	Input

(1) Software configured option

Figure 2-43: Digital Inputs Schematic (Aux I/O Connector)

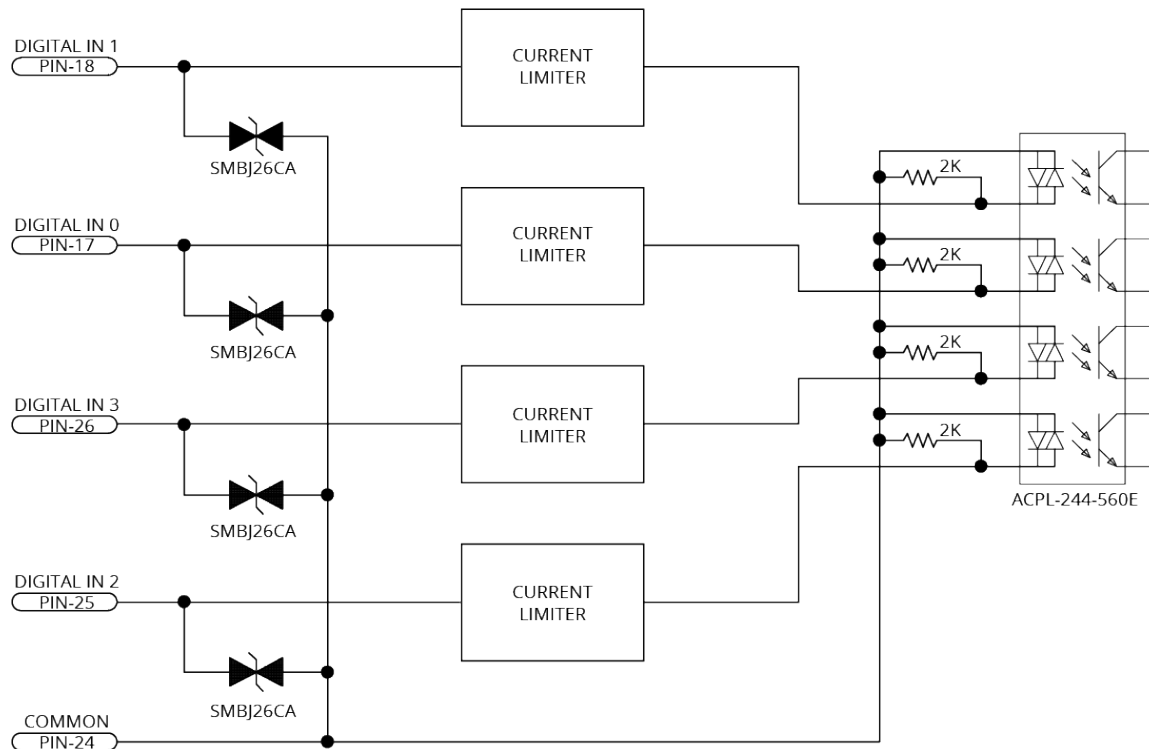

Figure 2-44: Digital Inputs Connected to Current Sourcing Devices

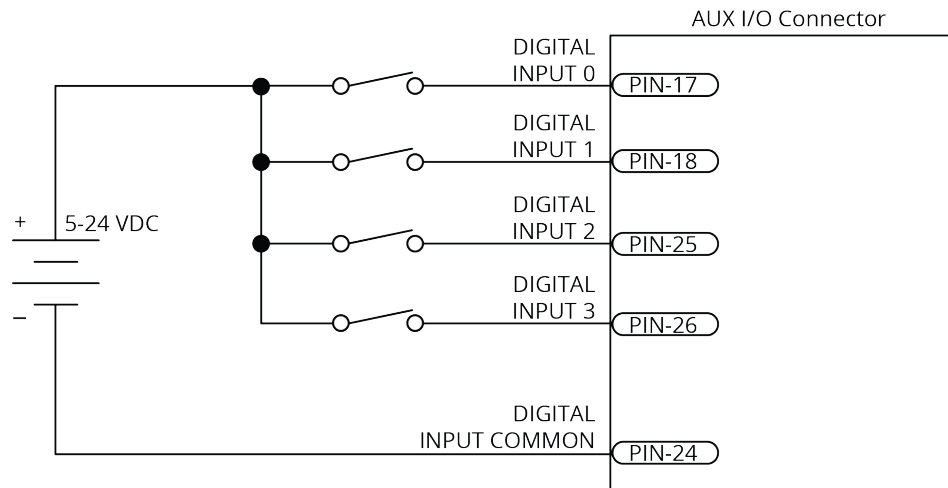
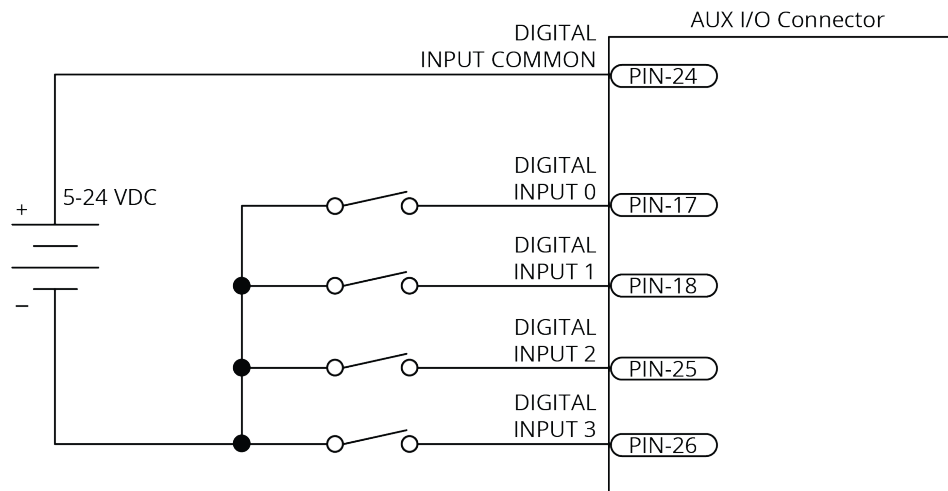

Figure 2-45: Digital Inputs Connected to Current Sinking Devices



2.5.5. High-Speed Inputs

High-speed inputs 20 and 21 can be used as general purpose inputs or as the trigger signal for high speed data collection. Refer to the DriveDataCaptureConfigureTrigger() function [A3200: DATAACQ TRIGGER command] topic in the Help file for more information.

You can use the external PSO synchronization functions [A3200: PSOOUTPUT PULSE EXTSYNC command] to synchronize waveform generation with an external synchronization signal. When you activate this feature, the PSO Waveform module will not generate the configured waveform when an output event is received until the rising edge of the synchronization signal occurs.

Table 2-46: High-Speed Input Specifications

Specification	Value
Input Voltage	5V - 24 V input voltages
Input Current	10 mA
Input Device	HCPL-0630
Delay	50 nsec

Table 2-47: High-Speed Input Pins on the Auxiliary I/O Connector

Pin#	Description	In/Out/Bi
3	High-Speed Input 20 + / PSO External Sync. +	Input
4	High-Speed Input 20 - / PSO External Sync. -	Input
5	High-Speed Input 21 +	Input
6	High-Speed Input 21 -	Input

Figure 2-46: High-Speed Inputs

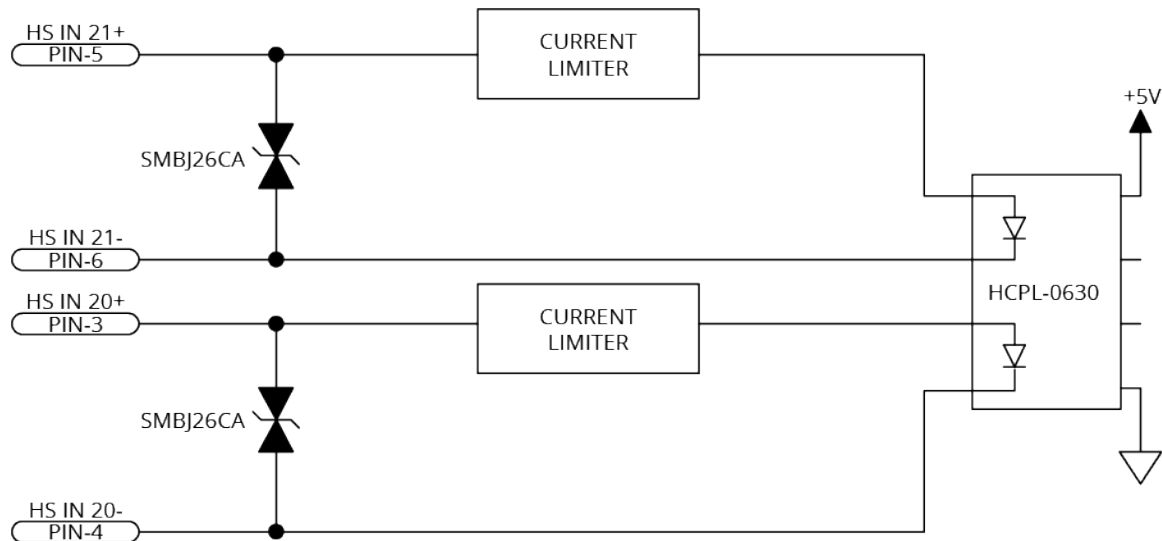

2.5.6. Analog Output 0

The analog output can be set from within a program or it can be configured to echo the state of select servo loop nodes.

The analog output is set to zero when you power on the system or reset the drive.

Table 2-48: Analog Output Specifications

Specification	Value
Output Voltage	-10 V to +10 V
Output Current	5 mA
Resolution (bits)	16 bits

Table 2-49: Analog Output Pins on the Auxiliary I/O Connector

Pin#	Description	In/Out/Bi
22	Analog Output 0	Output
23	Analog Common	Output

Figure 2-47: Analog Output 0 Schematic

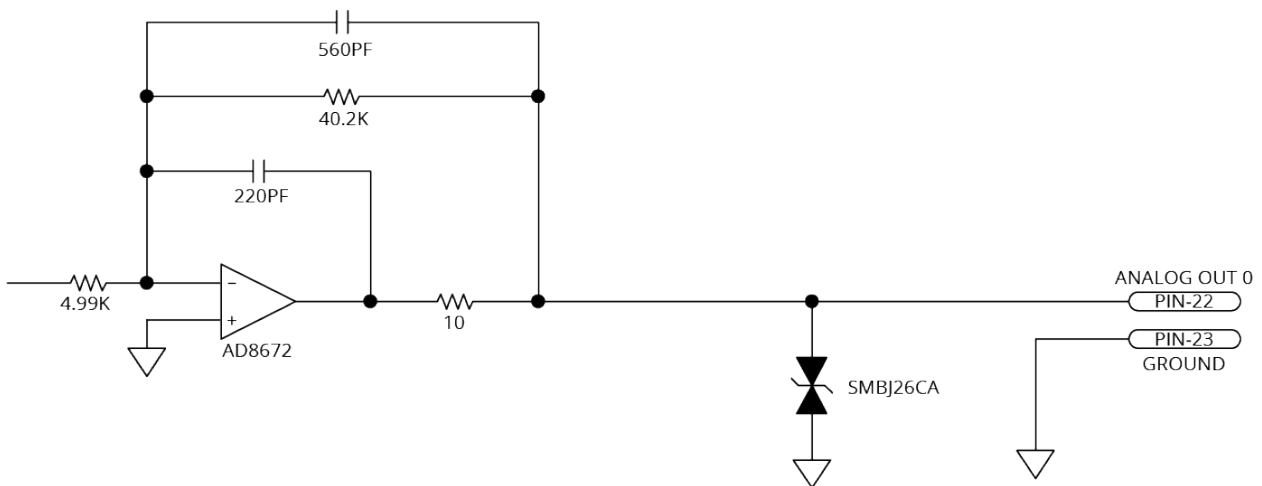

2.5.7. Analog Input 0 (Differential)

To interface to a single-ended, non-differential voltage source, connect the signal common of the source to the negative input and connect the analog source signal to the positive input. A floating signal source must be referenced to the analog common. Refer to [Figure 2-48](#).

Table 2-50: Analog Input Specifications

Specification	Value
(AI+) - (AI-)	+10 V to -10 V ⁽¹⁾
Resolution (bits)	16 bits
Input Impedance	1 MΩ
1. Signals outside of this range may damage the input	

Table 2-51: Analog Input Pins on the Auxiliary I/O Connector

Pin#	Description	In/Out/Bi
13	Analog Input 0+ (Differential)	Input
14	Analog Input 0- (Differential)	Input
23	Analog Common	Output

Figure 2-48: Analog Input 0 Schematic

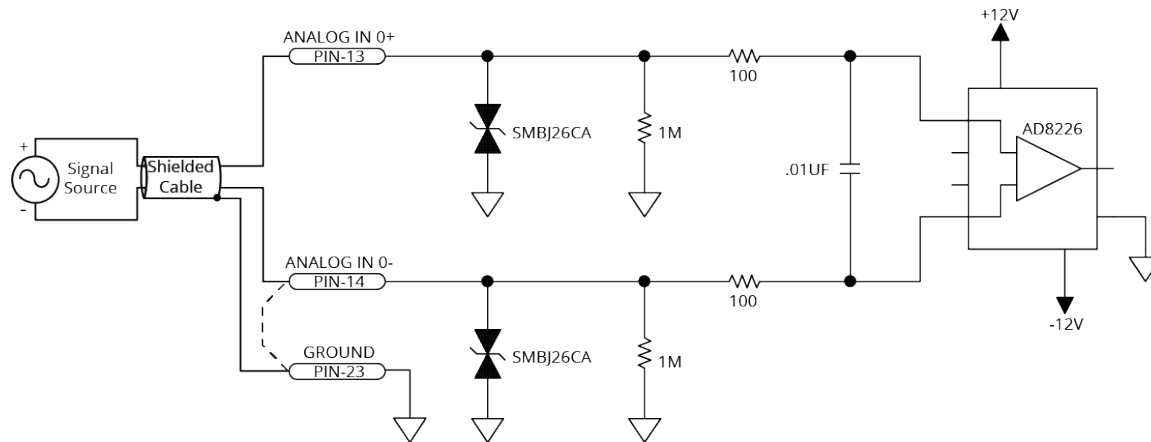

2.6. Brake Power Supply Connector

This port is the power supply connection to the on-board brake control circuit. Refer to [Section 2.3.6](#) for more information about the brake output interface.

Table 2-52: Brake Power Supply Connector Pinout

Pin#	Description	In/Out/Bi	Connector
1	Brake Power Supply (+)	Input	
2	Brake Power Supply (-)	Input	

Table 2-53: Brake Power Supply Mating Connector Ratings

Specification		Description
Type		2-Pin Terminal Block
Part Numbers		Aerotech: ECK02391
		Phoenix: 1827635
Conductor Cross Section	One conductor, stranded with ferrule and plastic sleeve	18...22 AWG (0.25...0.75 mm ²)
	Two conductors (same cross-section), stranded, twin ferrule with plastic sleeve	20 AWG (0.5 mm ²)
Tightening Torque		0.22...0.25 N·m
Conductor Insulation Strip Length		7 mm (0.25 in)
(1) Refer to the manufacturer website for additional information.		

2.7. HyperWire Interface

The HyperWire bus is the high-speed communications connection from the controller. It operates at 2 gigabits per second. The controller sends all command and configuration information through the HyperWire bus. This device consumes one of the available axes of control on the HyperWire communication network. Refer to your Automation1-iSMC license for the number of available HyperWire axes.

HyperWire cables can be safely connected to or disconnected from a HyperWire port while the PC and/or drive is powered on. However, any changes to the HyperWire network topology will disrupt communication and you must reset the controller to re-establish communication.



WARNING: Do not connect or disconnect HyperWire cables while you are loading firmware or damage to the drives may occur.

Table 2-54: HyperWire Card Part Number

Part Number	Description
HYPERWIRE-PCIE	HyperWire adapter, PCIe x4 interface

Table 2-55: HyperWire Cable Part Numbers

Part Number	Description
HYPERWIRE-AO10-5	HyperWire cable, active optical, 0.5 m
HYPERWIRE-AO10-10	HyperWire cable, active optical, 1.0 m
HYPERWIRE-AO10-30	HyperWire cable, active optical, 3.0 m
HYPERWIRE-AO10-50	HyperWire cable, active optical, 5.0 m
HYPERWIRE-AO10-200	HyperWire cable, active optical, 20.0 m

2.8. External Shunt Option [-SX1]

The -SX1 option provides a connection for a user-provided shunt resistor to dissipate excess energy and keep the internal drive voltage within safe levels. The drive switches this resistor "ON" when the internal bus voltage reaches approximately 380 VDC. This option is generally required for systems that have a large amount of stored mechanical energy that must be dissipated during deceleration.

DANGER: Shock and Fire Hazard



Electrical wiring must be designed and installed in accordance with local electrical safety regulations to prevent the risk of fire and electrical shock.

The shunt resistor dissipates a high quantity of power. To prevent the danger of electric shock or fire, you must obey the precautions that follow:

- Correctly size, mount, and protect the external shunt resistor.
- Do not touch the shunt resistor terminals. There are lethal voltages on the terminals.
- Do not touch the surface of the drive or the external shunt resistor. The temperature can exceed 70°C.
- Restrict access to the shunt resistor while it is connected to a power source.

Table 2-56: -SX1 Component Information

Component	Description	Aerotech P/N
Recommended Shunt Resistor	50 Ω (min), 300 W Vishay/Dale: RBEF030050R00KFBVT	ECR01039
1-Pin Mating Connector [QTY. 2]	Screw Torque Value: 0.6 - 0.8 N·m Wire Size: 0.2 - 6 mm ² [24-10 AWG] Phoenix: 0708250	ECK02452
F101 Fuse on the Control Board	8 A S.B.	EIF01022
Recommended Wire Size	16 AWG (1.3 mm ²) High Temperature	--

Equation 1:

Calculate the kinetic energy of the system. Any energy that is not lost to the system could be regenerated to the DC bus.

$$E_M = [1/2] [J_M + J_L] \omega_M^2 \quad ; \text{ rotary motors}$$

$$E_M = [1/2] [M_M + M_L] v_M^2 \quad ; \text{ linear motors}$$

Where:

$$J_M = \text{rotor inertia (kg} \cdot \text{m}^2\text{)}$$

$$J_L = \text{load inertia (kg} \cdot \text{m}^2\text{)}$$

$$\omega_M = \text{motor speed before deceleration (rad/s)}$$

$$M_M = \text{forcer mass (kg)}$$

$$M_L = \text{load mass (kg)}$$

$$v_M = \text{velocity (m/s)}$$

Equation 2:

You will need a shunt resistor if the regenerated energy is greater than the Maximum Additional Storage Energy that the internal bus capacitor can store (Table 2-57).

$$E_{Ca} = (1/2) \cdot C \cdot (V_M^2 - V_{NOM}^2)$$

Where:

C = bus capacitor (F) [1,200 μ F]

V_M = turn on voltage for shunt circuit (V) [380 V]

V_{NOM} = nominal bus voltage (V) [160 V or 320 V, Typical]

Table 2-57: Maximum Additional Storage Energy for a Standard iXC4e/XC4e

Bus Voltage	Maximum Additional Energy
160 V	71.3 J
320 V	25.2 J

If a shunt resistor is required, calculate the value of resistance necessary to dissipate the energy.

Equations 3, 4, and 5:

Calculate the parameters of the shunt resistor.

Equation 3:

$$P_{PEAK} = (E_M - E_{Ca}) / t_D$$

Where:

P_{PEAK} = peak power the regeneration circuit must accommodate (W)

t_D = deceleration time (s)

Equation 4:

$$P_{AV} = (E_M - E_{Ca}) / t_{CYCLE}$$

Where:

P_{AV} = average power dissipated on shunt resistor (W)

t_{CYCLE} = time between deceleration events (s)

Equation 5:

$$R = (2V_M - V_{HYS})^2 / 4P_{PEAK}$$

Where:

V_{HYS} = hysteresis voltage of regeneration circuit (V) [10 V, Typical]

Additional useful equations:

$$1 \text{ lb} \cdot \text{ft} = 1.356 \text{ N} \cdot \text{m}$$

$$1 \text{ rad/s} = 9.55 \text{ rpm}$$

2.9. Sync Port

The Sync port is a bi-directional high speed proprietary interface that lets you transmit encoder signals between drives. The drive contains two Sync ports, labeled A and B. To avoid signal contention, all Sync ports default to the input state during reset and immediately after power is applied to the drive.

This is typically used for multi-axis PSO applications where one or two drives send their encoder signals to a main drive that has the PSO logic and PSO output signal.

Table 2-58: Sync-Related Functions

Function	Description
DriveEncoderOutputConfigureDivider(), DriveEncoderOutputConfigureInput(), DriveEncoderOutputOn(), DriveEncoderOutputOff() [A3200: ENCODER OUT command]	Configure each Sync port as an input or an output
PsoDistanceConfigureInputs() [A3200: PSOTRACK INPUT command]	Let the PSO track the SYNC A or SYNC B port.
PsoWindowConfigureInput() [A3200: PSOWINDOW INPUT command]	

The Sync port uses low-voltage differential signaling (LVDS) and standard USB 3.0 type A (cross over) cables.

Table 2-59: Sync Port Cables

Part Number	Description
CBL-SYNC-3	Length 3 dm; Connectors: USB Type A to USB Type A
CBL-SYNC-5	Length 5 dm; Connectors: USB Type A to USB Type A
CBL-SYNC-7	Length 7 dm; Connectors: USB Type A to USB Type A
CBL-SYNC-10	Length 10 dm; Connectors: USB Type A to USB Type A

2.10. Industrial Ethernet (iXC4e Only)

The controller is equipped with 100BASE-TX Industrial Ethernet ports.



IMPORTANT: Industrial Ethernet is only available on the iXC4e.

- For the location of the ports, refer to [Figure 1-1](#).
- For cable part numbers, refer to [Table 4-1](#).
- For more information, refer to the Help system.

2.11. System Interconnection

Figure 2-49: Drive-Based System Wiring Drawing (Best Practice)

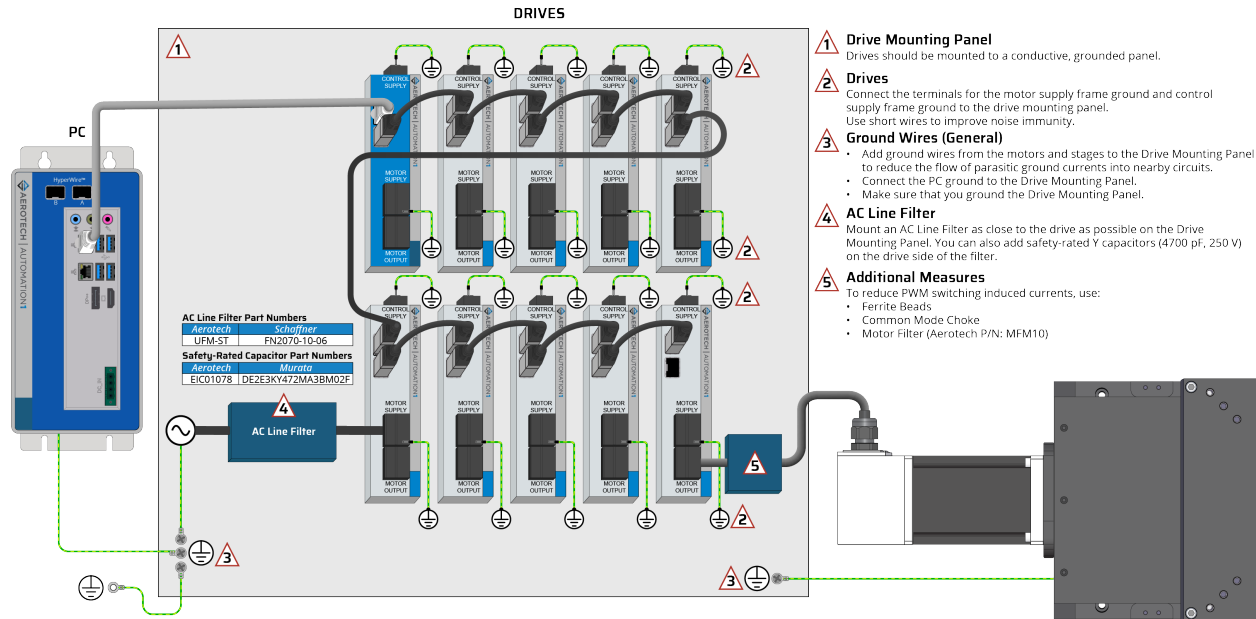

Figure 2-50: PC-Based System Wiring Drawing (Best Practice)

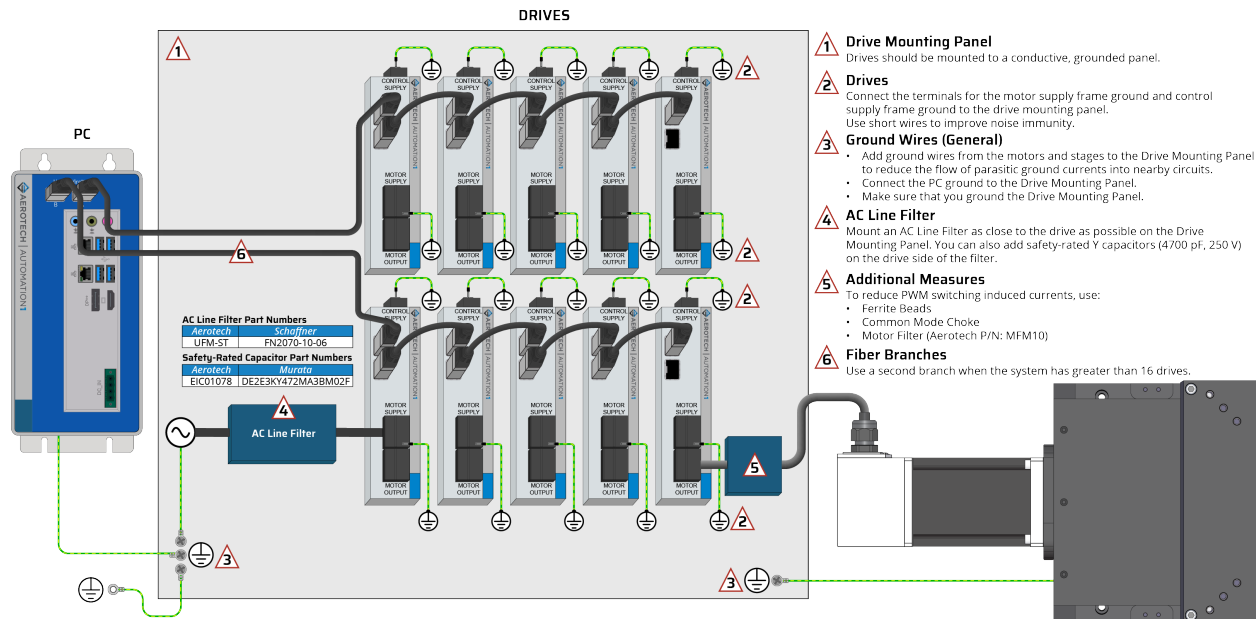
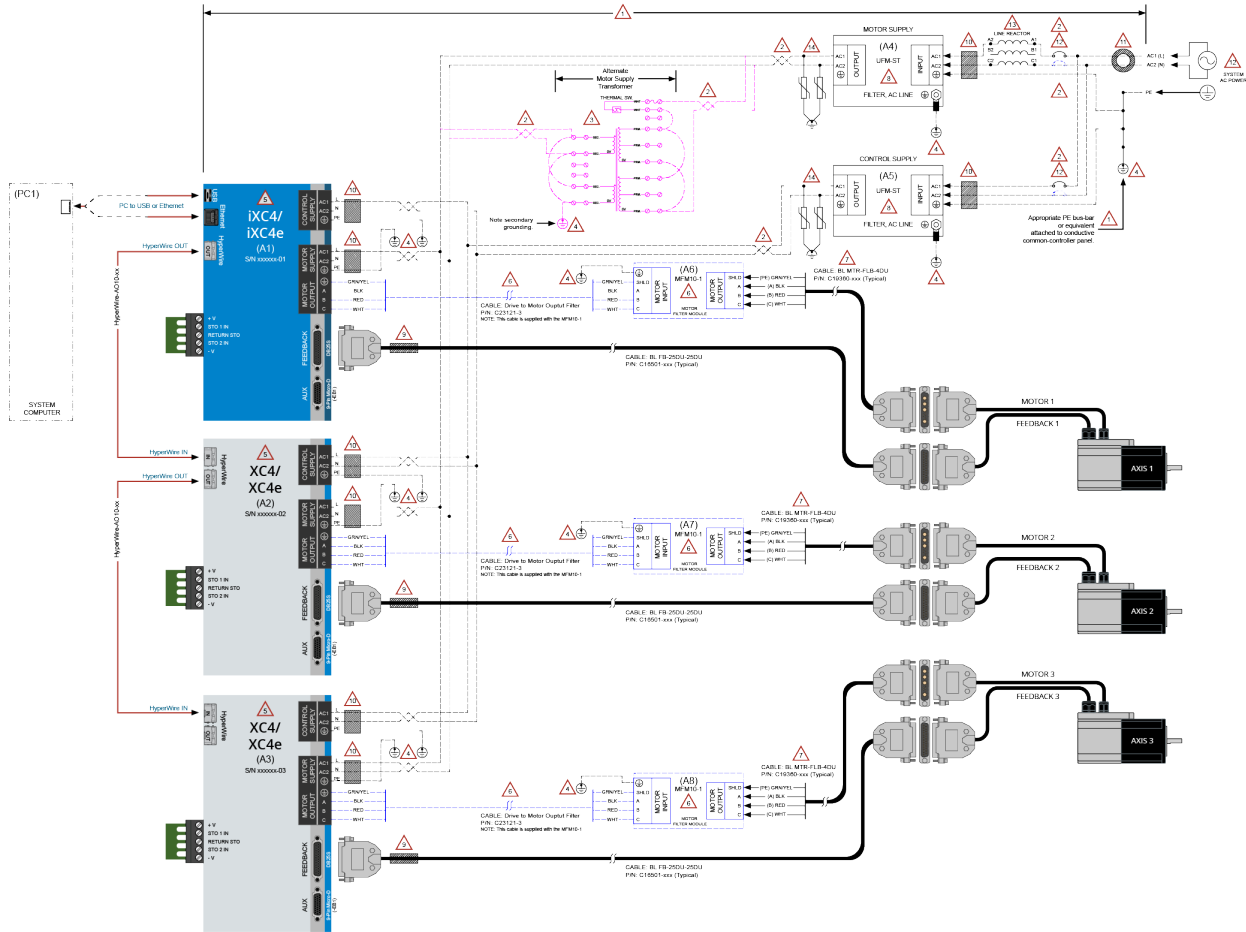
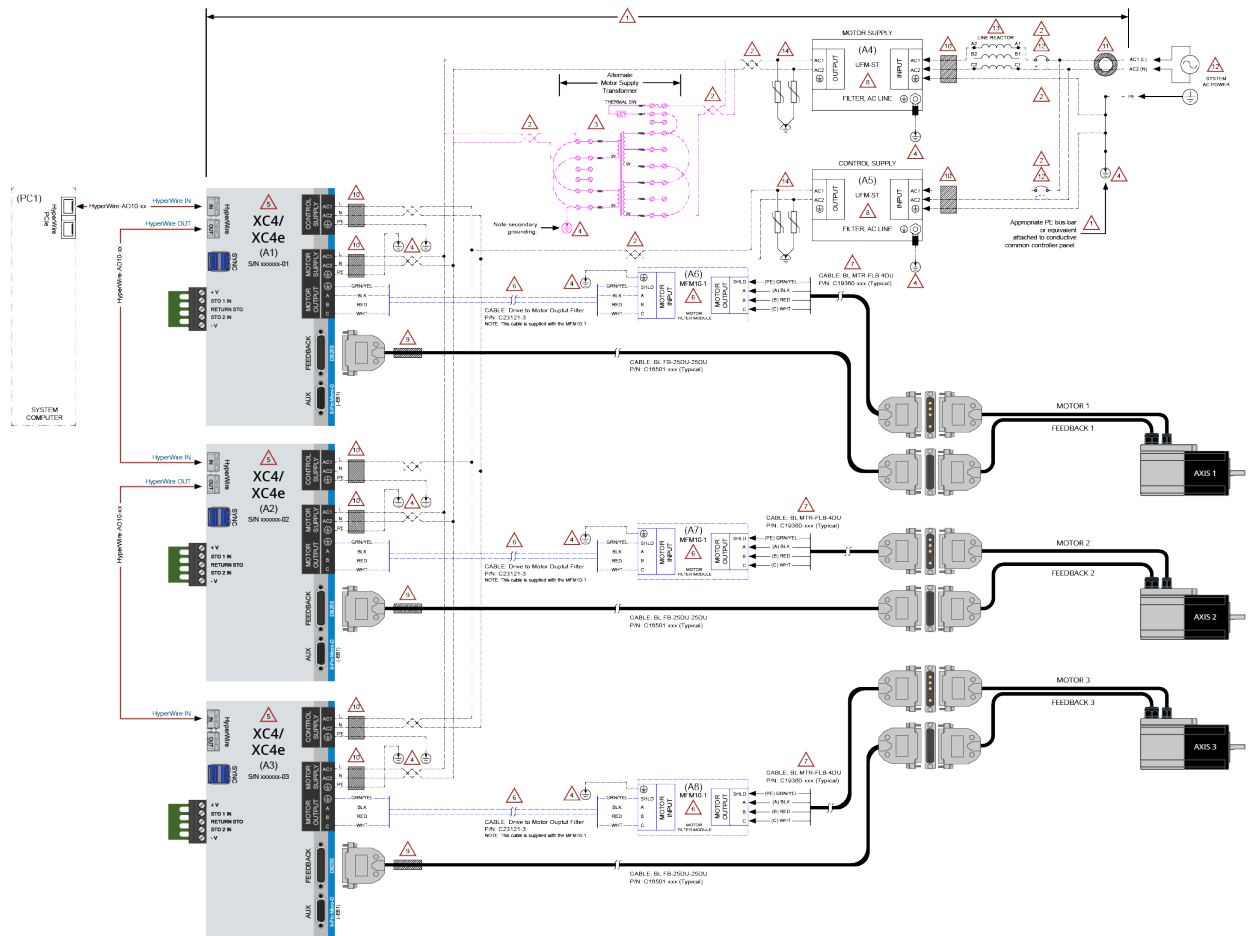

Figure 2-51: Recommended System Connections for a Drive-Based Controller



<p>! ATTENTION !</p> <p>The system integrator or end user is responsible for all safety compliance and technical requirements for the system wiring.</p> <p>IMPORTANT: Read all parts of this manual before you install or operate the drive or before you do maintenance to your system.</p> <ul style="list-style-type: none"> To prevent injury to you and damage to the equipment, obey the precautions in this manual. If you do not understand the information in this manual, contact Aerotech Global Technical Support. For additional resources, refer to https://www.aerotech.com/resources-manuals-help-files/. <p>For EMC performance, mount all system components on to a common conductive metal panel.</p> <ul style="list-style-type: none"> Do not use a panel that has painted or non-conductive coat applied. You can use a panel with a conductive surface coat. <p>Customer required wiring</p> <ul style="list-style-type: none"> The system integrator is responsible for all safety compliance and technical requirements. Aerotech recommends that you use AC1 & AC2 twisted pair conductors with crimp nuts as short as possible. When routing conductors, keep high voltage supply wiring separated from low voltage I/O or control/feedback signal wiring. 	<p>Alternate Motor Supply transformer (for reference only)</p> <p>Systems Protective Earth (PE) grounds</p> <ul style="list-style-type: none"> Keep PE wires as short as possible. Each PE wire should have a dedicated attachment/termination point. Recommendation: Terminate each PE directly to the grounded component panel. Refer to Note 1 above. <p>XC4, iXC4, XCA, and XC4e Drive</p> <ul style="list-style-type: none"> Refer to assemblies (A1), (A2), and (A3) If the drives were purchased as an integrated system, refer to the System Interconnections drawing included with the system documentation. Note that a drive's serial number is specific to an assigned axis. <p>OPTIONAL EQUIPMENT MFM10-1 (Motor Filter Module with 10ARMS Cable)</p> <ul style="list-style-type: none"> Refer to assemblies (A4), (A7), and (A8) For mechanical and electrical descriptions of the MFM10-1, refer to the Motor Filter Module Hardware Manual (MFM.pdf) at https://www.aerotech.com/resources-manuals-help-files/. Find the manual under the Controller Accessories category. <p>If the MFM10-1 is not used, connect the system motor cable directly to the controller MOTOR OUTPUT terminals.</p> <p>UFM-ST (Filter, AC Line Enclosure)</p> <ul style="list-style-type: none"> Refer to assemblies (A4) and (A5) For mechanical and electrical descriptions of the UFM-ST, refer to the UFM-ST Hardware Manual (UFMST.pdf) at https://www.aerotech.com/resources-manuals-help-files/. Find the manual under the Controller Accessories category. 	<p>Axis FEEDBACK cable Ferrite EMC filters</p> <ul style="list-style-type: none"> PN: Ferrite #0446167201 (Aerotech # EC22348) Clamp-On Construction Apply as close as possible to the FEEDBACK connector as illustrated <p>Drive Control Power and Motor Power -and- UFM-ST Ferrite EMC Filters</p> <ul style="list-style-type: none"> PN: Ferrite #0446164201 (Aerotech # EC22347) Clamp-On Construction Apply as close as possible to the power connector as illustrated <p>System AC Supply Ferrite EMC Filter</p> <ul style="list-style-type: none"> PN: Ferrite # J E320220 300 (Aerotech # EC22368) Hand-Tight Construction Loop System AC1 and AC2 conductor pair two times through the toroid <p>System AC Power</p> <ul style="list-style-type: none"> #AC2 is not referenced to NEUTRAL, the AC2 line must have a fuse or circuit breaker protection. <p>LINE RE-ACCTING</p> <ul style="list-style-type: none"> Prevents source Amp/ohm faults during IIC surge testing Protects downstream circuits from supply transients Automotion Direct LR2-21 PC or equivalent <p>TRANSIENT VOLTAGE SURGE SUPPRESSORS</p> <ul style="list-style-type: none"> Prevents spurious Amplifier faults during IIC surge testing Protects downstream circuits from supply transients PN: Littelfuse V275-M40P or equivalent <p>The information on this page is for reference only and represents best practice applications.</p>
--	--	--

Figure 2-52: Recommended System Connections for a PC-Based Controller



<p>! ! ATTENTION ! !</p> <p>The system integrator or end user is responsible for all safety compliance and technical requirements for the system wiring.</p> <p>IMPORTANT: Read all parts of this manual before you install or operate the drive or before you do maintenance to your system.</p> <ul style="list-style-type: none"> To prevent injury to you and damage to the equipment, obey the precautions in this manual. If you do not understand the information in this manual, contact Aerotech Global Technical Support. For additional resources, refer to https://www.aerotech.com/resources-manuals-help-files/. <p>For EMC performance, mount all system components on to a common conductive metal panel.</p> <ul style="list-style-type: none"> Do not use a panel that has a painted or non-conductive coat applied. You can use a panel with a conductive surface coat. <p>Customer supplied wiring</p> <ul style="list-style-type: none"> The system integrator is responsible for all safety compliance and technical requirements. Aerotech recommends that you use AC1 & AC2 twisted pair conductors with circuit runs as short as possible. When routing conductors, keep high-voltage supply wiring separated from low-voltage I/O or control/feedback signal wiring. 	<p>Alternate Motor Supply transformer (for reference only)</p> <p>System Protective Earth (PE) grounds</p> <ul style="list-style-type: none"> Keep PE wires as short as possible. Each PE wire should have a dedicated attachment/termination point. Recommendation: Terminate each PE directly to the grounded component panel. Refer to Note 1 above. <p>XC4e and XC4e Controllers</p> <ul style="list-style-type: none"> Refer to assemblies (A1), (A2), and (A3). If the controllers were purchased as an integrated system, refer to the System Interconnections drawing included with the system documentation. Note that a controller's serial number is specific to an assigned axis. <p>OPTIONAL EQUIPMENT: MFM-1 Motor Filter Module with 10BARMS Cable</p> <ul style="list-style-type: none"> Refer to assemblies (A5), (A7), and (A8). For mechanical and electrical descriptions of the MFM-1, refer to the Motor Filter Module Hardware Manual (MFM-1.pdf) at https://www.aerotech.com/resources-manuals-help-files/. <p>If the MFM-1 is not used, connect the system motor cable directly to the controller MOTOR OUTPUT terminals.</p> <p>UFM-ST (Filter, AC Line Enclosure)</p> <ul style="list-style-type: none"> Refer to assemblies (A4) and (A5). For mechanical and electrical descriptions of the UFM-ST, refer to the UFM-ST Hardware Manual (UFM-ST.pdf) at https://www.aerotech.com/resources-manuals-help-files/. 	<p>Axis FEEDBACK cable Ferrite EMC filters</p> <ul style="list-style-type: none"> PN: Fair-Rite #0446197201 (Aerotech # EC202348) Clamp-On Construction Apply as close as possible to the FEEDBACK connector as illustrated. <p>XC4e/XC4e Controller Control Power and Motor Power and UFM-ST Ferrite EMC Filters</p> <ul style="list-style-type: none"> Clamp-On Construction PN: Fair-Rite #0446194281 (Aerotech # EC202347) Apply as close as possible to the power connector as illustrated. <p>System AC Supply Ferrite EMC Filter</p> <ul style="list-style-type: none"> PN: Laird # E302220 300 (Aerotech # EC202336) 100% Ring Construction Loop System AC1 and AC2 conductor pair two times through the ferrite. <p>System AC Power</p> <ul style="list-style-type: none"> If AC2 is not referenced to NEUTRAL, the AC2 line must have a fuse or circuit breaker protection. <p>LINE REACTOR</p> <ul style="list-style-type: none"> Prevents spurious Amplifier Faults during IEC surge testing. Protects downstream circuits from supply transients. Automation Direct LR2-21 PD or equivalent. <p>TRANSIENT VOLTAGE SURGE SUPPRESSORS</p> <ul style="list-style-type: none"> Prevents spurious Amplifier Faults during IEC surge testing. Protects downstream circuits from supply transients. PN: Littelfuse# V27L45ADP or equivalent. <p>The information on this page is for reference only and represents best practice applications.</p>
--	---	---

2.12. PC Configuration and Operation Information

For more information about hardware requirements, PC configuration, programming, system operation, and utilities, refer to the Help file.

Chapter 3: -EB1 Option Expansion Board

The -EB1 I/O option board has 16 digital inputs, 16 digital outputs, 3 analog inputs, 3 analog outputs, and PSO outputs.

Figure 3-1: -EB1 I/O Option Board Connectors (iXC4e shown)

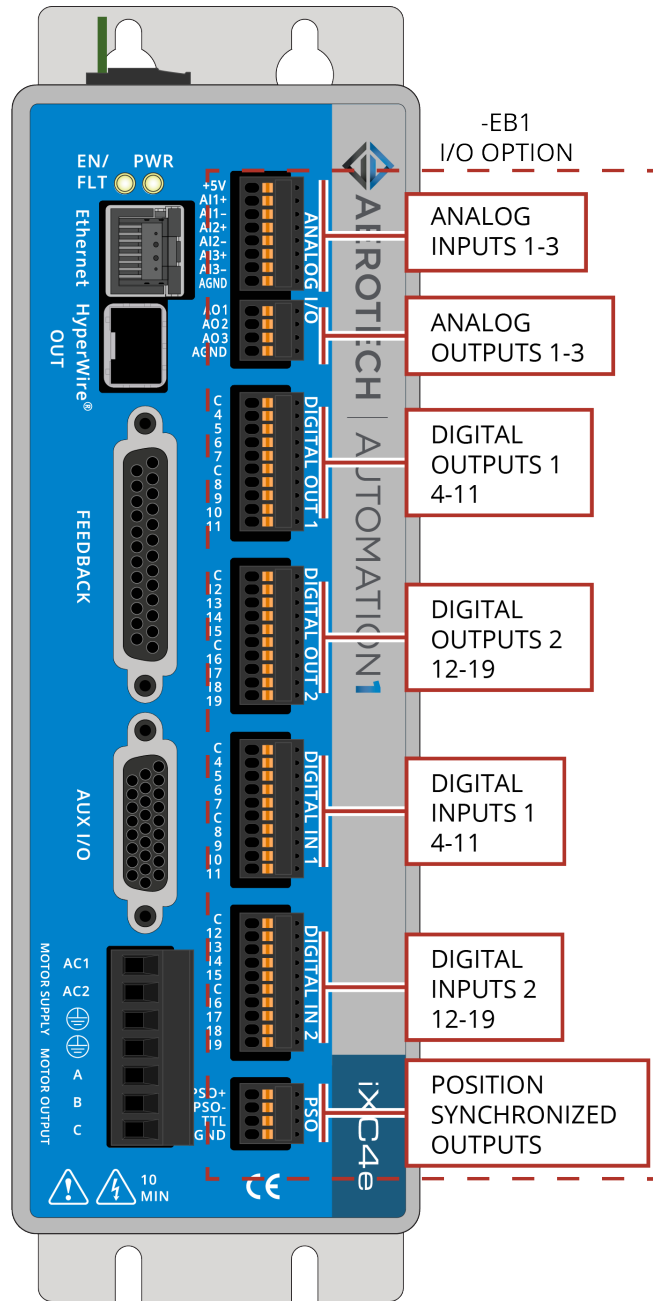

3.1. Digital Outputs [-EB1]

Optically-isolated solid-state relays drive the digital outputs. You can connect the digital outputs in current sourcing or current sinking mode but you must connect all four outputs in a port in the same configuration. Refer to [Figure 3-3](#) and [Figure 3-4](#).

The digital outputs are not designed for high-voltage isolation applications and they should only be used with ground-referenced circuits.

You must install suppression diodes on digital outputs that drive relays or other inductive devices. To see an example of a current sourcing output that has diode suppression, refer to [Figure 3-3](#). To see an example of a current sinking output that has diode suppression, refer to [Figure 3-4](#).

The digital outputs have overload protection. They will resume normal operation when the overload is removed.

Table 3-1: Digital Output Specifications [-EB1]

Digital Output Specifications	Value
Maximum Voltage	24 V (26 V Maximum)
Maximum Sink/Source Current	250 mA/output
Output Saturation Voltage	0.9 V at maximum current
Output Resistance	3.7 Ω
Rise / Fall Time	250 μ s (2K pull up to 24V)
Reset State	Output Off (High Impedance State)

Table 3-2: Digital Output 1 Connector Pinout [-EB1]

Pin#	Description	In/Out/Bi	Connector
1	Output Common for Outputs 4-7	Output	
2	Output 4 (Optically-Isolated)	Output	
3	Output 5 (Optically-Isolated)	Output	
4	Output 6 (Optically-Isolated)	Output	
5	Output 7 (Optically-Isolated)	Output	
6	Output Common for Outputs 8-11	Output	
7	Output 8 (Optically-Isolated)	Output	
8	Output 9 (Optically-Isolated)	Output	
9	Output 10 (Optically-Isolated)	Output	
10	Output 11 (Optically-Isolated)	Output	

Table 3-3: Digital Output 2 Connector Pinout [-EB1]

Pin#	Description	In/Out/Bi	Connector
1	Output Common for Outputs 12-15	Output	
2	Output 12 (Optically-Isolated)	Output	
3	Output 13 (Optically-Isolated)	Output	
4	Output 14 (Optically-Isolated)	Output	
5	Output 15 (Optically-Isolated)	Output	
6	Output Common for Outputs 16-19	Output	
7	Output 16 (Optically-Isolated)	Output	
8	Output 17 (Optically-Isolated)	Output	
9	Output 18 (Optically-Isolated)	Output	
10	Output 19 (Optically-Isolated)	Output	

Table 3-4: Digital Output 1 and 2 Mating Connector Ratings [-EB1]

Specification		Description
Type		10-Pin Terminal Block
Part Numbers		Aerotech: ECK02395
		Phoenix: 1700841
Conductor Cross Section	Solid or stranded	20...26 AWG (0.14...0.5 mm ²)
	Stranded, with ferrule, without plastic sleeve	20...24 AWG (0.25...0.5 mm ²)
Conductor Insulation Strip Length		8 mm (5/16 in)
(1) Refer to the manufacturer website for additional information.		

Figure 3-2: Digital Outputs Schematic [-EB1]

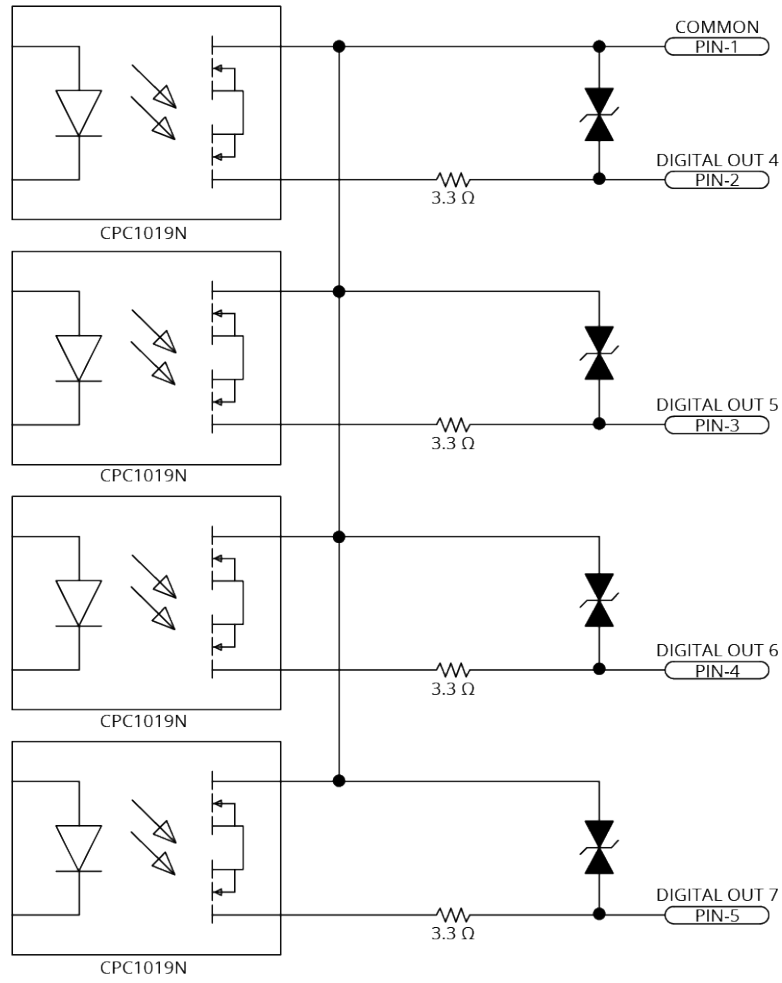
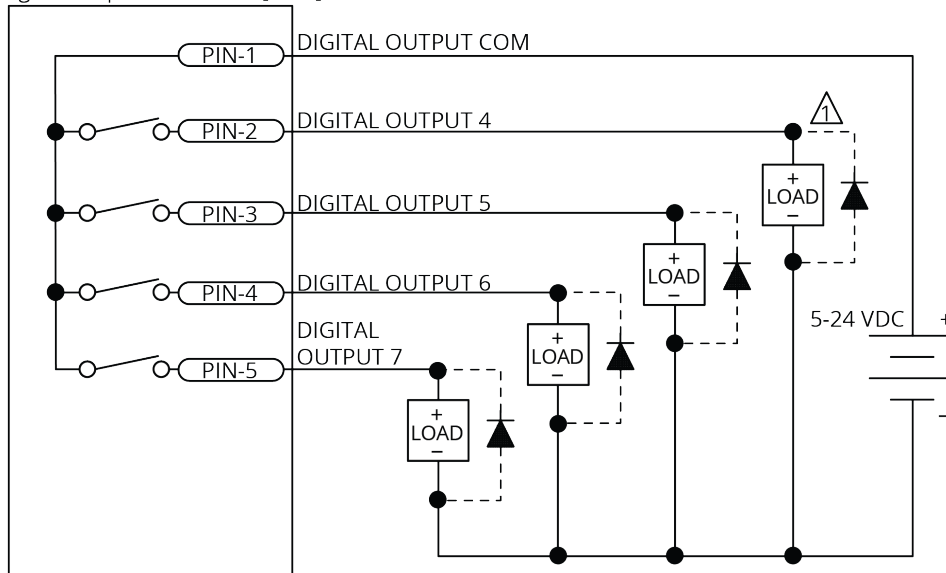

Figure 3-3: Digital Outputs Connected in Current Sourcing Mode [-EB1]

Digital Output Connector [-EB1]



DIODE REQUIRED ON EACH OUTPUT THAT DRIVES AN INDUCTIVE DEVICE (COIL), SUCH AS A RELAY.

Figure 3-4: Digital Outputs Connected in Current Sinking Mode [-EB1]

Digital Output Connector [-EB1]

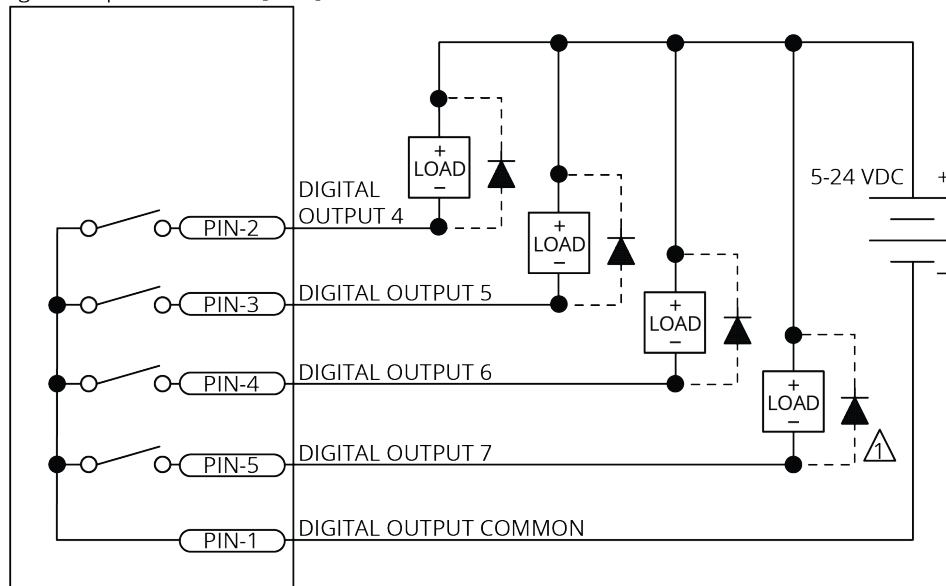

DIODE REQUIRED ON EACH OUTPUT THAT DRIVES AN INDUCTIVE DEVICE (COIL), SUCH AS A RELAY.

3.2. Digital Inputs [-EB1]

Input bits are arranged in groups of 4 and each group shares a common pin. This lets a group be connected to current sourcing or current sinking devices, based on the connection of the common pin in that group.

To be able to connect an input group to current sourcing devices, connect the input group's common pin to the power supply return (-). Refer to [Figure 3-6](#).

To be able to connect an input group to current sinking devices, connect the input group's common pin to the power supply source (+). Refer to [Figure 3-7](#).

The digital inputs are not designed for high-voltage isolation applications. They should only be used with ground-referenced circuits.

Table 3-5: Digital Input Specifications [-EB1]

Input Voltage	Approximate Input Current	Turn On Time	Turn Off Time
+5 V to +24 V	6 mA	10 μ s	43 μ s

Table 3-6: Digital Input 1 Connector Pinout [-EB1]

Pin#	Description	In/Out/Bi	Connector
1	Input Common for Inputs 4-7	Output	
2	Input 4 (Optically-Isolated)	Input	
3	Input 5 (Optically-Isolated)	Input	
4	Input 6 (Optically-Isolated)	Input	
5	Input 7 (Optically-Isolated)	Input	
6	Input Common for Inputs 8-11	Output	
7	Input 8 (Optically-Isolated)	Input	
8	Input 9 (Optically-Isolated)	Input	
9	Input 10 (Optically-Isolated)	Input	
10	Input 11 (Optically-Isolated)	Input	

Table 3-7: Digital Input 2 Connector Pinout [-EB1]

Pin#	Description	In/Out/Bi	Connector
1	Input Common for Inputs 12-15	Output	
2	Input 12 (Optically-Isolated)	Input	
3	Input 13 (Optically-Isolated)	Input	
4	Input 14 (Optically-Isolated)	Input	
5	Input 15 (Optically-Isolated)	Input	
6	Input Common for Inputs 16-19	Output	
7	Input 16 (Optically-Isolated)	Input	
8	Input 17 (Optically-Isolated)	Input	
9	Input 18 (Optically-Isolated)	Input	
10	Input 19 (Optically-Isolated)	Input	

Table 3-8: Digital Input 1 and 2 Mating Connector Ratings [-EB1]

Specification		Description
Type		10-Pin Terminal Block
Part Numbers		Aerotech: ECK02395 Phoenix: 1700841
Conductor Cross Section	Solid or stranded	20...26 AWG (0.14...0.5 mm ²)
	Stranded, with ferrule, without plastic sleeve	20...24 AWG (0.25...0.5 mm ²)
Conductor Insulation Strip Length		8 mm (5/16 in)
(1) Refer to the manufacturer website for additional information.		

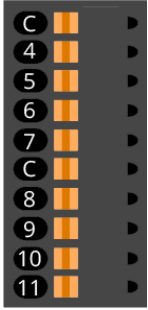
Figure 3-5: Digital Inputs Schematic [-EB1]

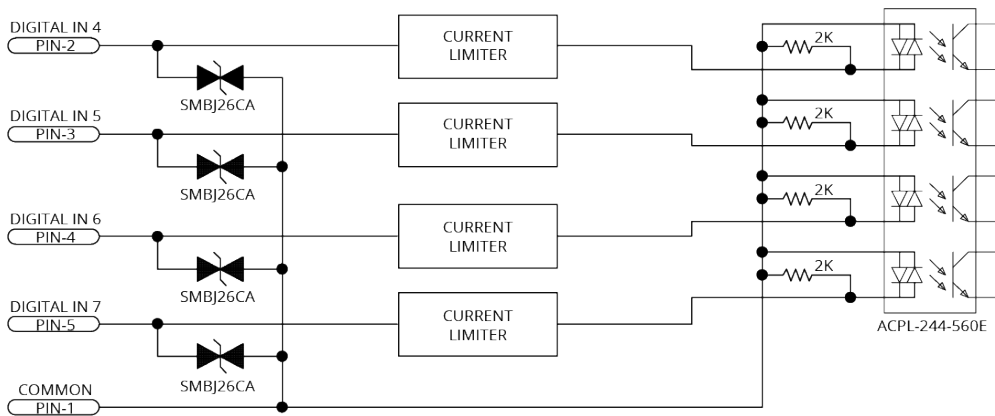



IMPORTANT: Each bank of four inputs must be connected in an all sourcing or all sinking configuration.

Figure 3-6: Digital Inputs Connected to Current Sourcing (PNP) Devices [-EB1]

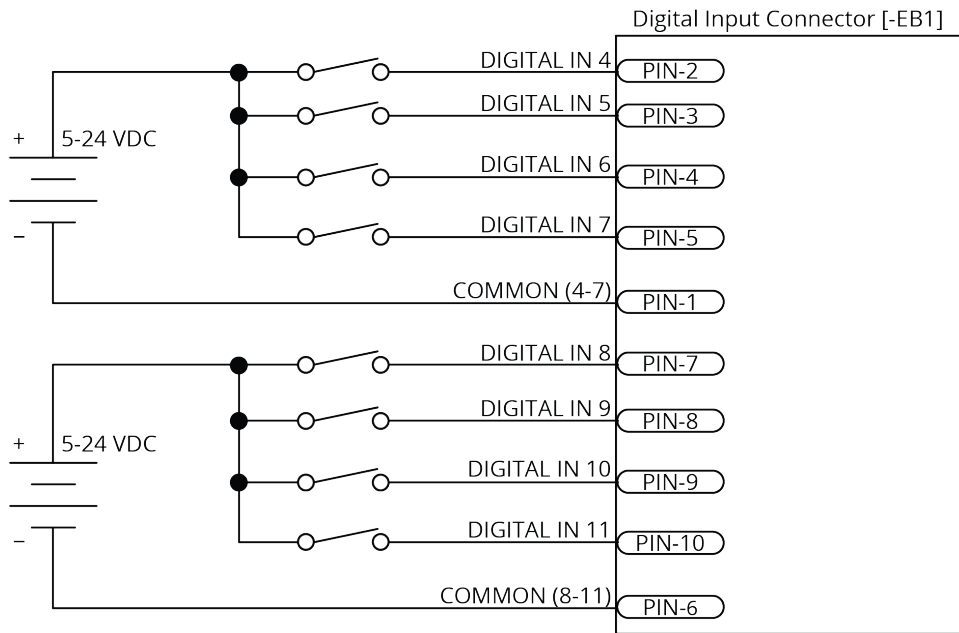
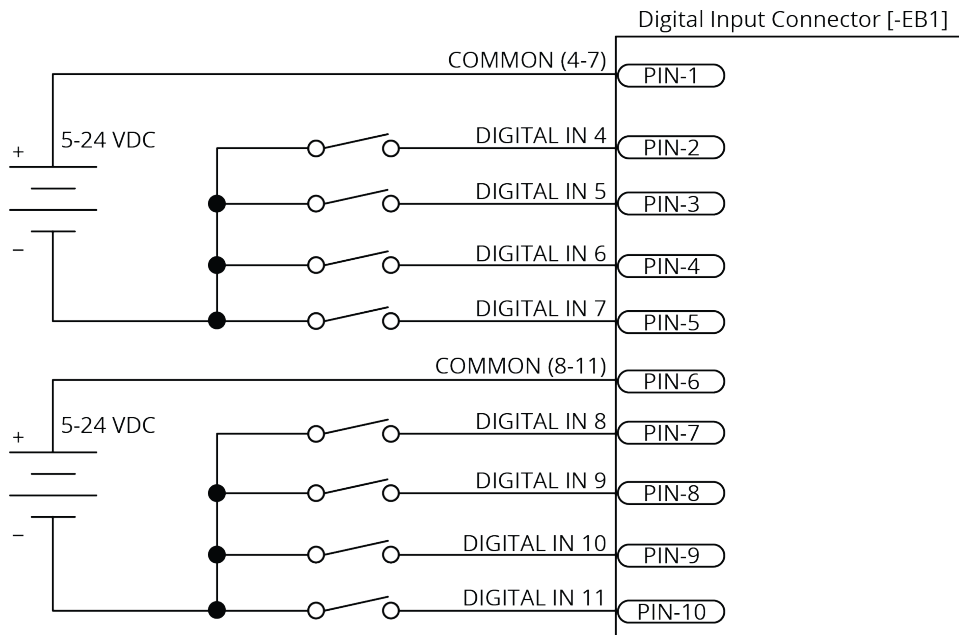

Figure 3-7: Digital Inputs Connected to Current Sinking (NPN) Devices [-EB1]



3.3. Analog Outputs [-EB1]

The analog outputs can be set from within a program or they can be configured to echo the state of select servo loop nodes.

The analog outputs are set to zero when you power on the system or reset the drive.

Table 3-9: Analog Output Specifications [-EB1]

Specification	Value
Output Voltage	-10 V to +10 V
Output Current	5 mA
Resolution (bits)	16 bits

Table 3-10: Analog Output Connector Pinout [-EB1]

Pin #	Description	In/Out/Bi	Connector
1	Analog Output 1	Output	
2	Analog Output 2	Output	
3	Analog Output 3	Output	
4	Ground	N/A	

Table 3-11: Analog Output Mating Connector Ratings [-EB1]

Specification	Description
Type	4-Pin Terminal Block
Part Numbers	Aerotech: ECK02399
	Phoenix: 1768004
Conductor Cross Section	Solid or stranded
	Stranded, with ferrule, without plastic sleeve
Conductor Insulation Strip Length	8 mm (5/16 in)

(1) Refer to the manufacturer website for additional information.

Figure 3-8: Analog Output Typical Connection [-EB1]

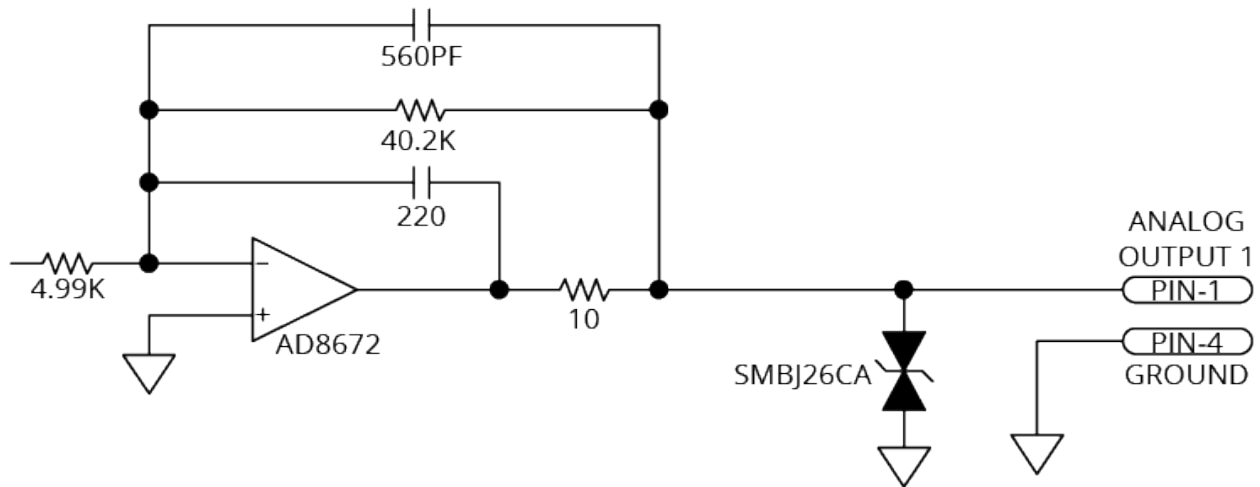

3.4. Analog Inputs [-EB1]

To interface to a single-ended, non-differential voltage source, connect the signal common of the source to the negative input and connect the analog source signal to the positive input. A floating signal source must be referenced to the analog common. Refer to [Figure 3-9](#).

Table 3-12: Differential Analog Input Specifications [-EB1]

Specification	Value
(AI+) - (AI-)	+10 V to -10 V ⁽¹⁾
Resolution (bits)	16 bits
Input Impedance	1 MΩ
1. Signals outside of this range may damage the input	

Table 3-13: Analog Input Connector Pinout [-EB1]

Pin#	Description	In/Out/Bi	Connector
1	+5V (250 mA max)	Output	
2	Analog Input 1+	Input	
3	Analog Input 1-	Input	
4	Analog Input 2+	Input	
5	Analog Input 2-	Input	
6	Analog Input 3+	Input	
7	Analog Input 3-	Input	
8	Ground	N/A	

Table 3-14: Analog Input Mating Connector Ratings [-EB1]

Specification	Description
Type	8-Pin Terminal Block
Part Numbers	Aerotech: ECK02397
	Phoenix: 1908101
Conductor Cross Section	Solid or stranded
	Stranded, with ferrule, without plastic sleeve
Conductor Insulation Strip Length	8 mm (5/16 in)
(1) Refer to the manufacturer website for additional information.	

Figure 3-9: Analog Input Typical Connection [-EB1]

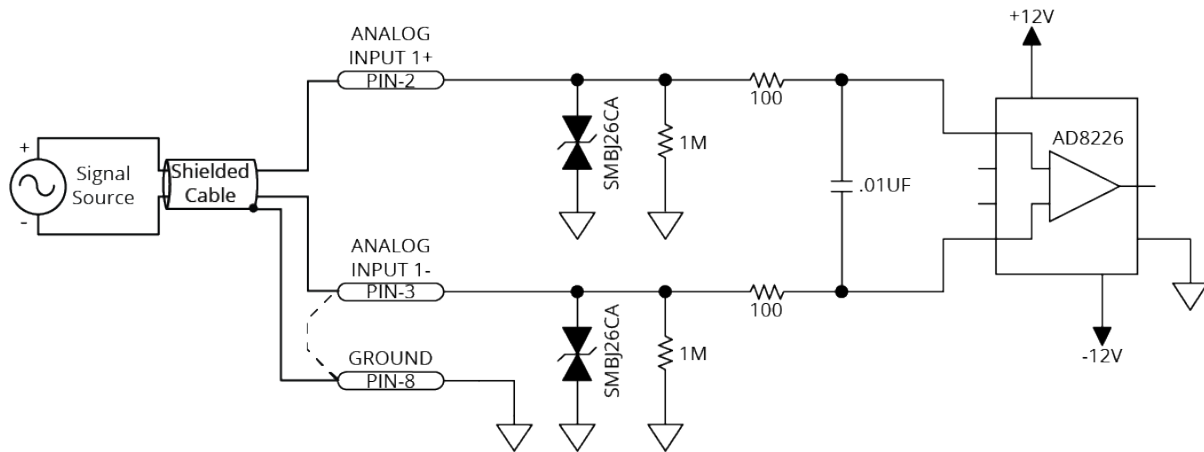

3.5. PSO Interface [-EB1]

The Position Synchronized Output (PSO) signal is available on the -EB1 option board in two signal formats: TTL and Isolated.

The PSO signal is also available on the AUX I/O connector. Refer to [Section 2.5.2](#).

Table 3-15: PSO Specifications [-EB1]

Specification		Value
Output	TTL	5 V, 16 mA (max)
	Isolated	5-24 V, 250 mA
Maximum PSO Output (Fire) Frequency	TTL	12.5 MHz
	Isolated	5 MHz
Output Latency [Fire event to output change]	TTL	15 ns
	Isolated	160 ns

Table 3-16: PSO Interface Connector Pinout [-EB1]

Pin #	Description	In/Out/Bi	Connector
1	PSO Output+	Output	
2	PSO Output-	Output	
3	PSO Output (TTL)	Output	
4	Ground	N/A	

Table 3-17: PSO Interface Mating Connector Ratings [-EB1]

Specification		Description
Type		4-Pin Terminal Block
Part Numbers		Aerotech: ECK02399
		Phoenix: 1768004
Conductor Cross Section	Solid or stranded	20...26 AWG (0.14...0.5 mm ²)
	Stranded, with ferrule, without plastic sleeve	20...24 AWG (0.25...0.5 mm ²)
Conductor Insulation Strip Length		8 mm (5/16 in)
(1) Refer to the manufacturer website for additional information.		

Isolated Signals

This output signal is a fully-isolated 5-24V compatible output capable of sourcing or sinking current. This output is normally open and only conducts current when a PSO fire event occurs.

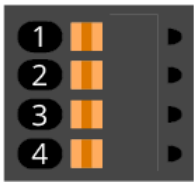
The PSO Isolated Outputs are overload protected and will turn off if the maximum output current is exceeded.

Figure 3-10: PSO Output Sources Current

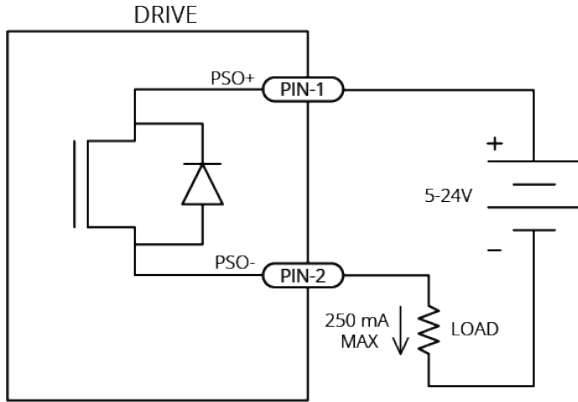
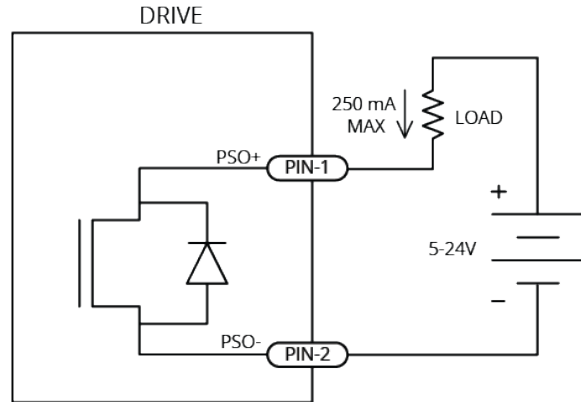

Figure 3-11: PSO Output Sinks Current



TTL Signals

This output signal is a 5V TTL signal which is used to drive an opto coupler or general purpose TTL input. This signal is active high and is driven to 5V when a PSO fire event occurs.

Figure 3-12: PSO TTL Outputs Schematic

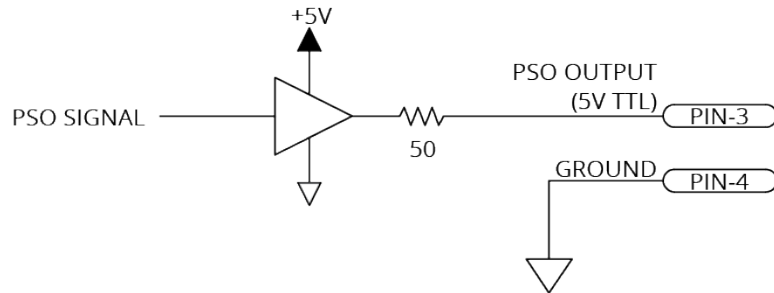

Chapter 4: Cables and Accessories

Table 4-1: Standard Interconnection Cables

Cable Part #	Description
Joystick	Refer to Section 4.1 .
HyperWire	Refer to Section 2.7 .
ECZ01231	BBA32 Interconnect Cable
ENET-CAT5e-xx ^(1, 2)	Ethernet CAT5e Cable
USB-AMCM-xx ^(1, 2, 3)	USB Cable A-Male to C-Male
<p>(1) The "-xx" indicates length in decimeters. (2) iXC4e Only (3) Make sure that you are using a shielded USB-C cable that is designed for data transfer.</p>	

4.1. Joystick Interface

Aerotech Multi-Axis Joystick (NEMA12 (IP54) rated) is powered from 5 V and has a nominal 2.5 V output in the center detent position. Three buttons are used to select axis pairs and speed ranges. An optional interlock signal is used to indicate to the controller that the joystick is present. Joystick control will not activate unless the joystick is in the center location. Third party devices can be used provided they produce a symmetric output voltage within the range of -10 V to +10 V.

Connecting joystick with an Aerotech cable, all Aerotech cables are labeled to identify the connector and connections. The joystick parameters must be set to match the analog and digital I/O connections. Refer to the Help file for programming information about how to change joystick parameters.

Figure 4-1: Two Axis Joystick Interface (to the Aux I/O of two drives)

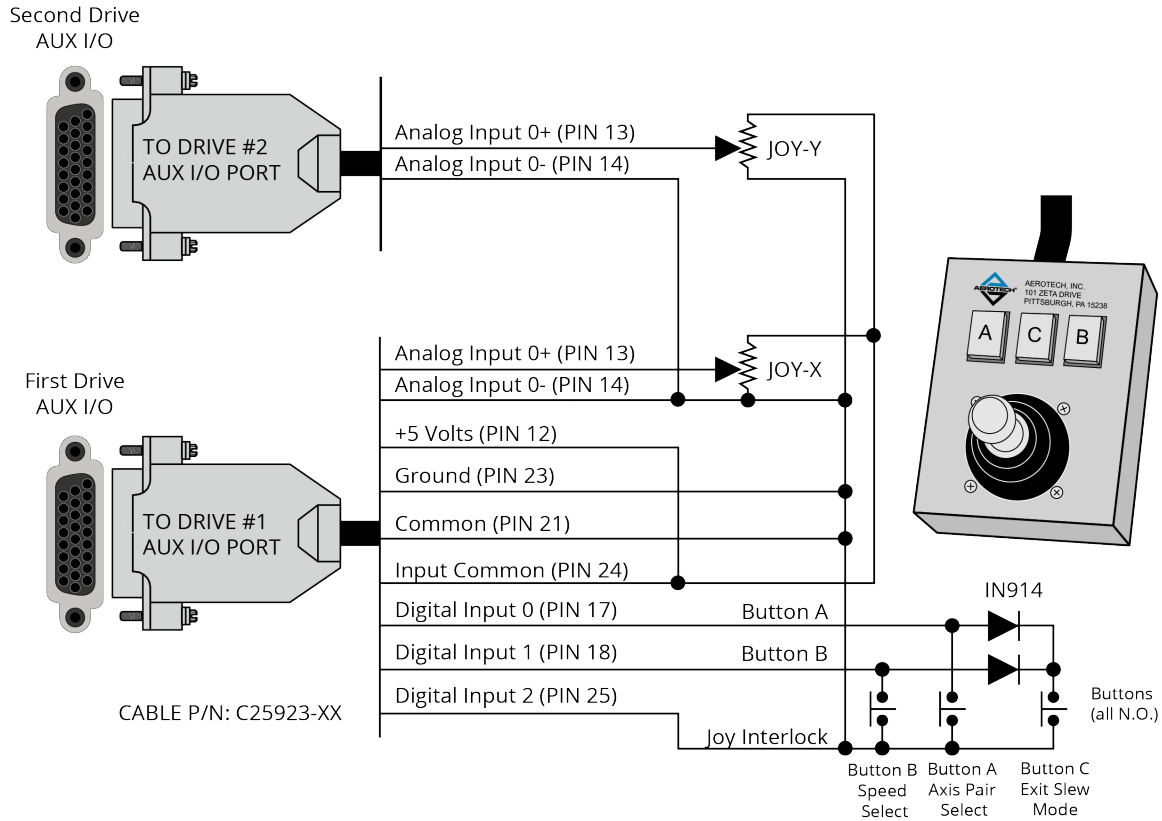
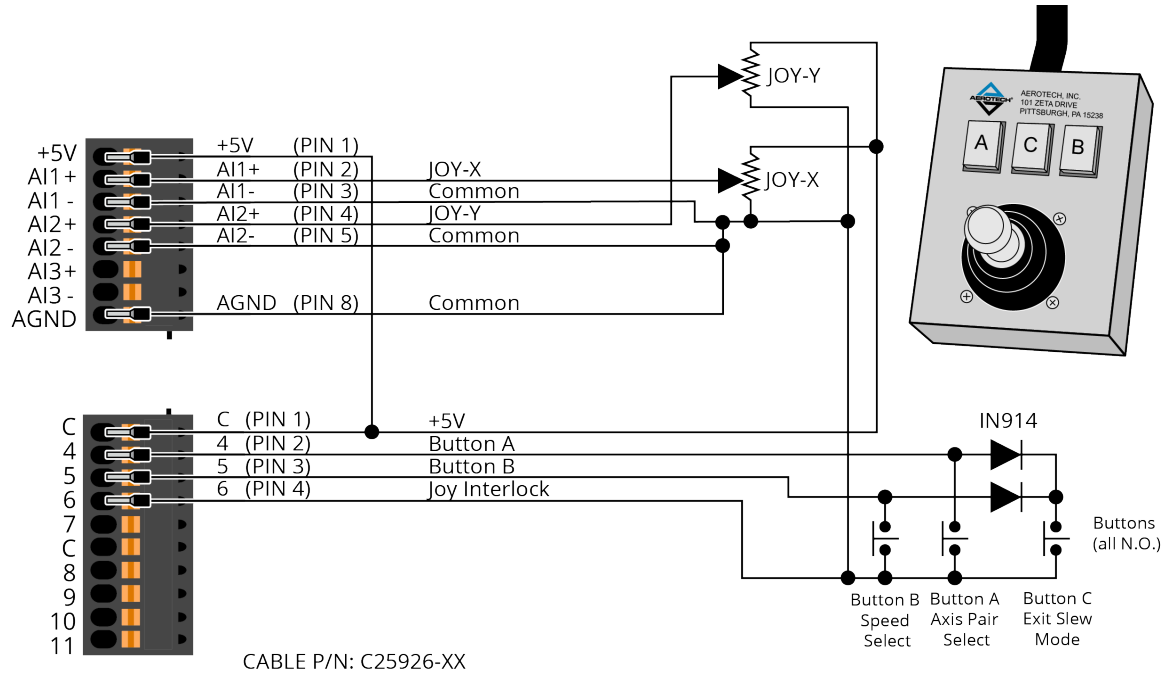

Figure 4-2: Two Axis Joystick Interface (to the I/O board)



4.2. Handwheel Interface

A handwheel can be used to manually control axis position. The handwheel must provide 5V differential quadrature signals to the drive.



IMPORTANT: You can find instructions on how to enable the handwheel in the online Help file.

Connect a handwheel to the Aux I/O as shown in [Figure 4-3](#) or [Figure 4-4](#).

Figure 4-3: Handwheel Interconnection to Aux I/O Connector

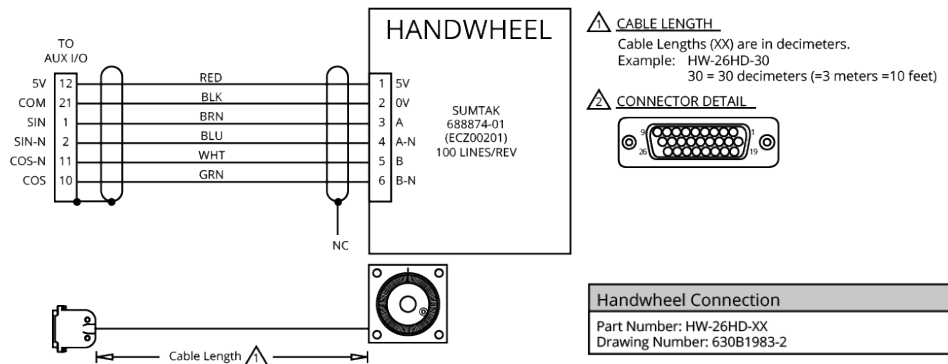
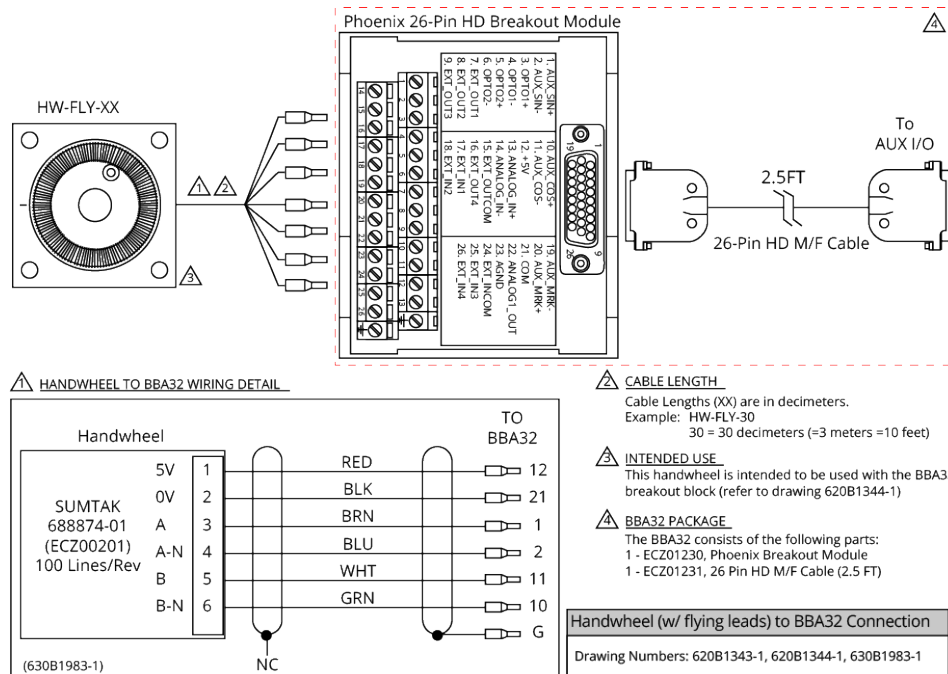

Figure 4-4: Handwheel Interconnection to the Aux I/O through a BBA32 Module



Chapter 5: Maintenance



IMPORTANT: For your own safety and for the safety of the equipment:

- Do not remove the cover of the iXC4e/XC4e.
- Do not attempt to access the internal components.

A fuse that needs to be replaced indicates that there is a more serious problem with the system or setup. Contact Global Technical Support for assistance.



DANGER: If you must remove the covers and access any internal components be aware of the risk of electric shock.

1. Disconnect the Mains power connection.
2. Wait at least ten (10) minutes after removing the power supply before doing maintenance or an inspection. Otherwise, there is the danger of electric shock.
3. All tests must be done by an approved service technician. Voltages inside the controller and at the input and output power connections can kill you.

Table 5-1: LED Description

LED	Color	Description
PWR	GREEN	The axis is powered on.
	RED ⁽¹⁾	The light will turn red when power is first applied, a communication problem occurs, or a drive reset is initiated. It will remain red during drive initialization.
EN/FLT	GREEN	The axis is Enabled.
	RED	The axis is in a Fault Condition.
	GREEN/RED (alternates)	The axis is Enabled in a Fault Condition. or The light is configured to blink for setup.

(1) Red PWR LED functionality is only present on some versions of the drive.

Table 5-2: Troubleshooting

Symptom	Possible Cause and Solution
No Communication	Make sure the power LED is illuminated (this indicates that power is present).
	Make sure that all communication cables (HyperWire, for example) are fully inserted in their ports.

5.1. Preventative Maintenance

Do an inspection of the iXC4e/XC4e and the external wiring one time each month. It might be necessary to do more frequent inspections based on:

- The operating conditions of the system.
- How you use the system.

Table 5-3: Preventative Maintenance

Check	Action to be Taken
Examine the chassis for hardware and parts that are damaged or loose. It is not necessary to do an internal inspection unless you think internal damage occurred.	Repair all damaged parts.
Do an inspection of the cooling vents.	Remove all material that collected in the vents.
Examine the work area to make sure there are no fluids and no electrically conductive materials.	Do not let fluids and electrically conductive material go into the chassis.
Examine all cables and connections to make sure they are correct.	Make sure that all connections are correctly attached and not loose. Replace cables that are worn. Replace all broken connectors.

Cleaning



DANGER: Before you clean the iXC4e/XC4e, disconnect the electrical power from the drive.

Use a clean, dry, soft cloth to clean the iXC4e/XC4e. If necessary, use a cloth that is moist with water or isopropyl alcohol. If you use a moist cloth, make sure that moisture does not go into the drive. Also make sure that it does not go onto the outer connectors and components. Internal contamination from the cleaning solution can cause corrosion and electrical short circuits.

Do not clean the labels with a cleaning solution because it might remove the label information.

5.2. Fuse Specifications



WARNING: Replace fuses only with the same type and value.

Table 5-4: Control Board Fuse Specifications

Fuse	Description	Size	SCCR (1)	Aerotech P/N	Third Party P/N
F100 (2)	Control Power at Line Input (L)	2 A S.B.	35 A	EIF01044	Littelfuse 0877002.MXEP
F101	-SX1 (External Shunt) Option	8 A S.B.	1500 A	EIF01022	Littelfuse 0215008.HXP
F102	Motor Bus Supply at AC1 (-10 Peak Current Option)	5 A S.B.	1500 A	EIF01023	Littelfuse 215005.HXP
	Motor Bus Supply at AC1 (-20/-30 Peak Current Option)	10 A S.B.		EIF01020	Littelfuse 0215010.HXP

(1) Short circuit current rating

(2) F100 is soldered into the PCB and is not user replaceable.

Figure 5-1: Fuse Locations on the iXC4e Control Board

NOTE: iXC4e Control board is shown. The fuse locations are the same on the XC4e.

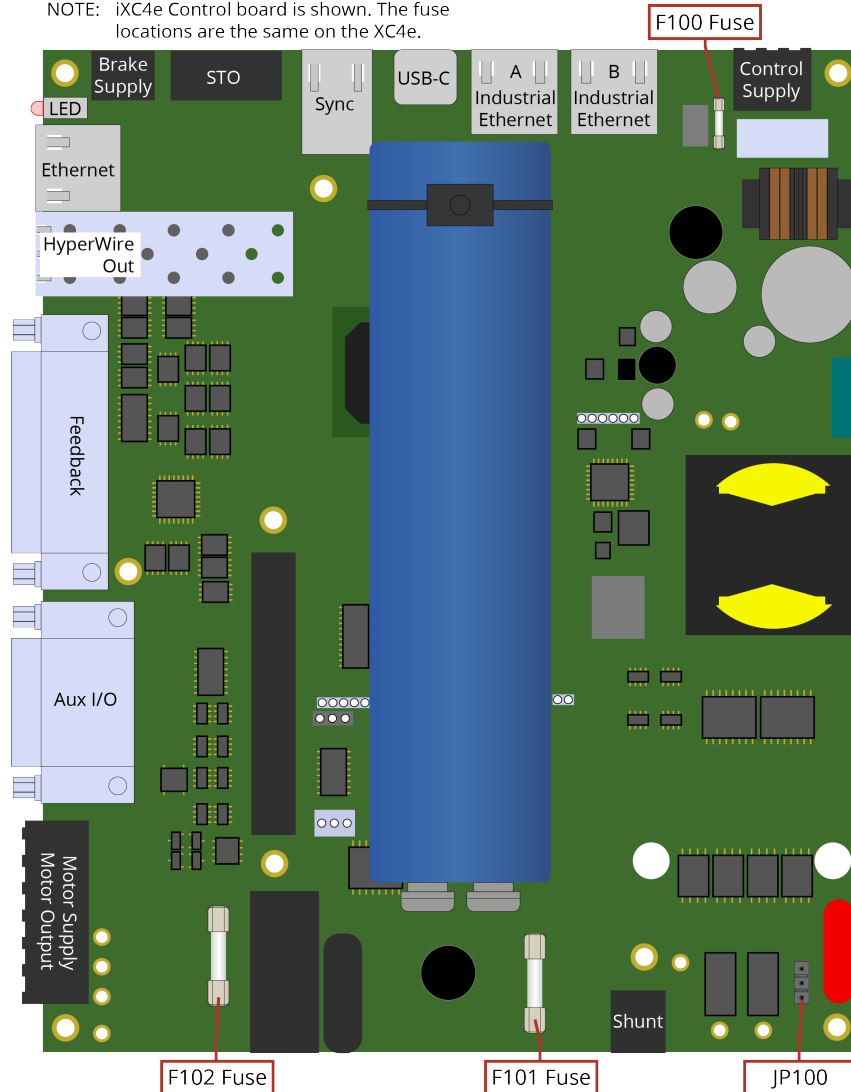

This page intentionally left blank.

Appendix A: Warranty and Field Service

Aerotech, Inc. warrants its products to be free from harmful defects caused by faulty materials or poor workmanship for a minimum period of one year from date of shipment from Aerotech. Aerotech's liability is limited to replacing, repairing or issuing credit, at its option, for any products that are returned by the original purchaser during the warranty period. Aerotech makes no warranty that its products are fit for the use or purpose to which they may be put by the buyer, whether or not such use or purpose has been disclosed to Aerotech in specifications or drawings previously or subsequently provided, or whether or not Aerotech's products are specifically designed and/or manufactured for buyer's use or purpose. Aerotech's liability on any claim for loss or damage arising out of the sale, resale, or use of any of its products shall in no event exceed the selling price of the unit.

THE EXPRESS WARRANTY SET FORTH HEREIN IS IN LIEU OF AND EXCLUDES ALL OTHER WARRANTIES, EXPRESSED OR IMPLIED, BY OPERATION OF LAW OR OTHERWISE. IN NO EVENT SHALL AEROTECH BE LIABLE FOR CONSEQUENTIAL OR SPECIAL DAMAGES.

Return Products Procedure

Claims for shipment damage (evident or concealed) must be filed with the carrier by the buyer. Aerotech must be notified within thirty (30) days of shipment of incorrect material. No product may be returned, whether in warranty or out of warranty, without first obtaining approval from Aerotech. No credit will be given nor repairs made for products returned without such approval. A "Return Materials Authorization (RMA)" number must accompany any returned product(s). The RMA number may be obtained by calling an Aerotech service center or by submitting the appropriate request available on our website (www.aerotech.com). Products must be returned, prepaid, to an Aerotech service center (no C.O.D. or Collect Freight accepted). The status of any product returned later than thirty (30) days after the issuance of a return authorization number will be subject to review.

Visit [Global Technical Support Portal](#) for the location of your nearest Aerotech Service center.

Returned Product Warranty Determination

After Aerotech's examination, warranty or out-of-warranty status will be determined. If upon Aerotech's examination a warranted defect exists, then the product(s) will be repaired at no charge and shipped, prepaid, back to the buyer. If the buyer desires an expedited method of return, the product(s) will be shipped collect. Warranty repairs do not extend the original warranty period.

Fixed Fee Repairs - Products having fixed-fee pricing will require a valid purchase order or credit card particulars before any service work can begin.

All Other Repairs - After Aerotech's evaluation, the buyer shall be notified of the repair cost. At such time the buyer must issue a valid purchase order to cover the cost of the repair and freight, or authorize the product(s) to be shipped back as is, at the buyer's expense. Failure to obtain a purchase order number or approval within thirty (30) days of notification will result in the product(s) being returned as is, at the buyer's expense.

Repair work is warranted for ninety (90) days from date of shipment. Replacement components are warranted for one year from date of shipment.

Rush Service

At times, the buyer may desire to expedite a repair. Regardless of warranty or out-of-warranty status, the buyer must issue a valid purchase order to cover the added rush service cost. Rush service is subject to Aerotech's approval.

On-site Warranty Repair

If an Aerotech product cannot be made functional by telephone assistance or by sending and having the customer install replacement parts, and cannot be returned to the Aerotech service center for repair, and if Aerotech determines the problem could be warranty-related, then the following policy applies:

Aerotech will provide an on-site Field Service Representative in a reasonable amount of time, provided that the customer issues a valid purchase order to Aerotech covering all transportation and subsistence costs. For warranty field repairs, the customer will not be charged for the cost of labor and material. If service is rendered at times other than normal work periods, then special rates apply.

If during the on-site repair it is determined the problem is not warranty related, then the terms and conditions stated in the following "On-Site Non-Warranty Repair" section apply.

On-site Non-Warranty Repair

If any Aerotech product cannot be made functional by telephone assistance or purchased replacement parts, and cannot be returned to the Aerotech service center for repair, then the following field service policy applies:

Aerotech will provide an on-site Field Service Representative in a reasonable amount of time, provided that the customer issues a valid purchase order to Aerotech covering all transportation and subsistence costs and the prevailing labor cost, including travel time, necessary to complete the repair.

Service Locations

<https://www.aerotech.com/contact-sales.aspx?mapState=showMap>

USA, CANADA, MEXICO

Aerotech, Inc.
Global Headquarters

CHINA

Aerotech China
Full-Service Subsidiary

GERMANY

Aerotech Germany
Full-Service Subsidiary

TAIWAN

Aerotech Taiwan
Full-Service Subsidiary

UNITED KINGDOM

Aerotech United Kingdom
Full-Service Subsidiary

Appendix B: Revision History

Revision	Description
2.15	Added MOV information to Section 2.1.2. Motor Supply Connector
2.14	Updated: <ul style="list-style-type: none"> Agency Approvals (Agency Approvals) Feature Summary (Section 1.1.) Table 5-1 (red power description)
2.13	Update to Section 1.4. Electrical Specifications
2.12	New: <ul style="list-style-type: none"> Korean Certification Updated: <ul style="list-style-type: none"> Agency Approvals Section 1.4. Electrical Specifications Section 2.4. Safe Torque Off Input (STO)
2.11	<ul style="list-style-type: none"> HyperWire axes documented System Interconnect drawing updated PSO Output latency updated
2.10	Revision changes have been archived. If you need a copy of this revision, contact AerotechGlobal Technical Support.
2.09	
2.08	
2.07	
2.06	
2.05	
2.04	
2.03	
2.02	
2.01	
2.00	
1.02	
1.01	
1.00	

This page intentionally left blank.

Index

-			
-EB1			
Analog Inputs	102		
Analog Outputs	101		
Digital Inputs	98		
Digital Outputs	94		
I/O Option Board	93		
Position Synchronized Output (PSO) Interface	103		
-MX2	52		
-MX3	52,72		
-SX1			
External Shunt Option	86		
		2	
2006/42/EC	9		
2014/30/EU	9		
2014/35/EU	9,12		
		A	
Absolute Encoder			
BiSS	51,71		
EnDat	51,71		
SSI	51,71		
Absolute Encoder (Auxiliary I/O Connector)	71		
Absolute Encoder (Feedback Connector)	51		
Absolute Encoder Schematic (Auxiliary I/O Connector)	71		
Absolute Encoder Schematic (Feedback Connector)	51		
Absolute Encoder Specifications (Auxiliary I/O Connector)	71		
Absolute Encoder Specifications (Feedback Connector)	51		
AC line filter	32		
Agency Approvals	12		
Altitude	29		
Analog Encoder (Aux Connector)	72		
Analog Encoder (Auxiliary I/O Connector)	52		
Analog Encoder Phasing Reference Diagram	72		
Analog Encoder Schematic (Auxiliary I/O Connector)	73		
Analog Encoder Specifications (Auxiliary I/O Connector)	72		
Analog Encoder Specifications (Feedback Connector)	52		
Analog Input 0 on the Aux I/O Connector	83		
Analog Input 0 Schematic (Aux I/O Connector)	83		
Analog Input 0 Specifications (Aux I/O Connector)	83		
Analog Input Connector [-EB1] Mating Connector Part Numbers	102		
Analog Input Connector Pinout [-EB1]	102		
Analog Input Pins (Aux I/O Connector)	83		
Analog Input Typical Connection [-EB1]	102		
Analog Inputs [-EB1]	102		
Analog Output 0 on the Aux I/O Connector	82		
Analog Output 0 Schematic (Aux I/O Connector)	82		
Analog Output 0 Specifications (Aux I/O Connector)	82		
Analog Output Connector [-EB1] Mating Connector Part Numbers	101		
Analog Output Connector Pinout [-EB1]	101		
Analog Output Pins (Aux I/O Connector)	82		
Analog Output Specifications [-EB1]	101		
Analog Output Typical Connection [-EB1]	101		
Analog Outputs [-EB1]	101		
Aux Connector			
Analog Encoder	72		
Sine Wave Encoder	72		
Aux I/O Connector			
Analog Input 0	83		
Analog Output 0	82		
Auxiliary Encoder Interface	69		
Digital Inputs	79		
Digital Outputs	76		
High-Speed User Inputs	81		
Position Synchronized Output	74		
PSO	74		
Aux I/O Connector Mating Connector Part Numbers	68		
Auxiliary Encoder (Aux I/O Connector)	69		
Auxiliary I/O Connector	68		
Absolute Encoder	71		
Analog Encoder	52		
RS-422 Line Driver Encoder	70		
Sine Wave Encoder	52		
Square Wave Encoder	70		
Auxiliary I/O Connector Pinout	68		
Auxiliary I/O Pins (Aux I/O Connector)	69		
		B	
BiSS absolute encoder	51,71		
Brake Connected to the Feedback Connector	61		
Brake Control Relay Specifications	61		
Brake Output Connector Pinout	84		
Brake Output Pins on the Feedback Connector	61		

Brake Outputs (Feedback Connector)	61	Digital Input 1 Connector Pinout [-EB1]	98
Brake Power Supply Connector	84	Digital Input 2 Connector [-EB1] Mating Connector Part Numbers	99
Brake Power Supply Connector Mating Connector Part Numbers	84	Digital Input 2 Connector Pinout [-EB1]	99
Brushless Motor Configuration (Motor Power Output Connector)	42	Digital Input Pins on the Aux I/O Connector	79
Brushless Motor Connections (Motor Power Output Connector)	42	Digital Input Specifications (Aux I/O Connector)	79
Brushless Motor Phasing Goal	44	Digital Input Specifications [-EB1]	98
Brushless Motor Phasing Oscilloscope Example	44	Digital Inputs (Aux I/O Connector)	79
Brushless Motor Powered Motor Phasing	43	Digital Inputs [-EB1]	98
Brushless Motor Unpowered Motor and Feedback Phasing	44	Digital Inputs Connected to a Current Sinking Device [-EB1]	100
		Digital Inputs Connected to a Current Sourcing Device [-EB1]	100
		Digital Inputs Connected to Current Sinking Devices (Aux I/O Connector)	80
		Digital Inputs Connected to Current Sourcing Devices (Aux I/O Connector)	80
		Digital Output 1 Connector [-EB1] Mating Connector Part Numbers	95
		Digital Output 1 Connector Pinout [-EB1]	95
		Digital Output 2 Connector [-EB1] Mating Connector Part Numbers	95
		Digital Output 2 Connector Pinout [-EB1]	95
		Digital Output Pins (Aux I/O Connector)	76
		Digital Output Schematic (Aux I/O Connector)	77
		Digital Output Specifications (Aux I/O Connector)	76
		Digital Output Specifications [-EB1]	94
		Digital Outputs (Aux I/O Connector)	76
		Digital Outputs [-EB1]	94
		Digital Outputs Connected in Current Sinking Mode (Aux I/O Connector)	78
		Digital Outputs Connected in Current Sinking Mode [-EB1]	97
		Digital Outputs Connected in Current Sourcing Mode (Aux I/O Connector)	78
		Digital Outputs Connected in Current Sourcing Mode [-EB1]	97
		Digital Outputs Schematic [-EB1]	96
		Dimensions	27
		Dimensions (without -EB1)	27
		Dimensions with -EB1	28
		Drawing number	15
		Drive and Software Compatibility	29
		Drive IP Rating	
		IP20	26
		E	
		Electrical Safety for Power Drive Systems	9-10

Electrical Specifications	24	Pinout	48
Minimum Load Inductance	24	Primary Encoder	49
Motor Type	24	RS-422 Line Driver Encoder	50
Power Amplifier Bandwidth	24	Square Wave Encoder	50
PWM Switching Frequency	24	Thermistor Input	56
SCCR	24	Travel Limit Input	58
User Power Supply Output	24	Feedback Monitoring	43
Electromagnetic Compatibility (EMC)	9	Figure	
EMC/CE Compliance	40	-EB1 I/O Option Board Connectors	93
Enclosure		Absolute Encoder Schematic (Auxiliary I/O Connector)	71
IP54 Compliant	26	Absolute Encoder Schematic (Feedback Connector)	51
encoder		Analog Encoder Schematic (Auxiliary I/O Connector)	73
absolute	51,71	Analog Input 0 Schematic (Aux I/O Connector)	83
Encoder (Feedback Connector)	49	Analog Input Typical Connection [-EB1]	102
Encoder and Hall Signal Diagnostics	43	Analog Output 0 Schematic (Aux I/O Connector)	82
Encoder Fault Input (Feedback Connector)	57	Analog Output Typical Connection [-EB1]	101
Encoder Fault Input Pin on the Feedback Connector	57	Brake Connected to the Feedback Connector	61
Encoder Phasing	54	Brushless Motor Configuration (Motor Power Output Connector)	42
Encoder Phasing Reference Diagram	54	Control Supply Connections	31
Encoder Pins on the Feedback Connector	49	DC Brush Motor Configuration (Motor Power Output Connector)	45
End of Travel Limit Input (Feedback Connector)	58	Digital Inputs Connected to a Current Sinking Device [-EB1]	100
End of Travel Limit Input Connections	59	Digital Inputs Connected to a Current Sourcing Device [-EB1]	100
End of Travel Limit Input Diagnostic Display	60	Digital Inputs Connected to Current Sinking Devices (Aux I/O Connector)	80
End of Travel Limit Input Pins on the Feedback Connector	58	Digital Inputs Connected to Current Sourcing Devices (Aux I/O Connector)	80
End of Travel Limit Phasing	60	Digital Output Schematic (Aux I/O Connector)	77
EnDat absolute encoder	51,71	Digital Outputs Connected in Current Sinking Mode (Aux I/O Connector)	78
Environmental Specifications	29	Digital Outputs Connected in Current Sourcing Mode (Aux I/O Connector)	78
EU 2015/863	9	Digital Outputs Schematic [-EB1]	96
examining parts		Dimensions (without -EB1)	27
cables	110	Dimensions with -EB1	28
connections	110	End of Travel Limit Input Connections	59
examining, dangerous fluids	110	End of Travel Limit Input Diagnostic Display	60
examining, dangerous material	110	Hall-Effect Inputs Schematic	55
External Shunt Option [-SX1]	86	High-Speed Inputs	81
		Home Limit Input Connections	59
		Home Limit Input Diagnostic Display	60
		Isolated Output Current Sinks Schematic (PSO)	104
		Isolated Output Current Sources Schematic (PSO)	104
F			
Feedback Connector	48		
Absolute Encoder	51		
Brake Outputs	61		
Encoder	49		
Encoder Fault Input	57		
End of Travel Limit Input	58		
Hall-Effect Inputs	55		
Home Limit Input	58		

Motor Supply Connections	32	I	
Outputs Connected in Current Sinking Mode [-IO]	97	I/O Option Board [-EB1]	93
Outputs Connected in Current Sourcing Mode [-EB1]	97	Input Power Connections	31
Positive Motor Direction	43	inspecting cooling vents	110
PSO Isolated Output Sinks Current	104	Inspection	110
PSO Isolated Output Sources Current	104	Installation and Configuration	31
PSO TTL Outputs Schematic	104	Installation Overview	16
Sine Wave Encoder Schematic (Auxiliary I/O Connector)	73	Introduction	19
Square Wave Encoder Inputs Schematic (Aux I/O Connector)	70	IP20 Drive IP Rating	26
Square Wave Encoder Schematic (Feedback Connector)	50	IP54 Compliant Enclosure	26
Stepper Motor Configuration	46	Isolated Output Current Sinks Schematic (PSO)	104
STO Timing	67	Isolated Output Current Sources Schematic (PSO)	104
Thermistor Input Schematic	56		
Three Phase Stepper Motor Configuration	47	J	
TTL Outputs Schematic (PSO)	104	Joystick Interface	106
Typical STO Configuration	63		
fluids, dangerous	110	K	
Functional Diagram	23	Korean Certification	11
Fuse Specifications	111		
Control Supply at L	111	L	
External Shunt (-SX1)	111	Laser Firing	74
Motor Supply at AC1	111		
		M	
H		Maintenance	109
Hall-Effect Feedback Pins on the Feedback Connector	55	material, electrically conductive	110
Hall-Effect Inputs (Feedback Connector)	55	Mating Connector	
Hall-Effect Inputs Schematic	55	Analog Output Connector [-EB1]	101
Handling	15	Mating Connector P/N	
Handwheel Interconnection (to Aux I/O through a BBA32 Module)	108	Analog Input Connector [-EB1]	102
Handwheel Interconnection to the Aux I/O Connector	108	Aux I/O Connector	68
Handwheel Interface	108	Brake Power Supply Connector	84
High-Speed Input Pins on the Aux I/O Connector	81	Control Supply Connector	31
High-Speed Input Specifications	81	Digital Input 2 Connector [-EB1]	99
High-Speed Inputs	81	Digital Output 1 Connector [-EB1]	95
High-Speed User Inputs (Aux I/O Connector)	81	Digital Output 2 Connector [-EB1]	95
Home Limit Input (Feedback Connector)	58	Feedback Connector	48
Home Limit Input Connections	59	Motor Power Output Connector	41
Home Limit Input Diagnostic Display	60	PSO Connector [-EB1]	103
Home Limit Input Pins on the Feedback Connector	58	STO Connector	62
Humidity	29	Mechanical Specifications	26
HyperWire	85	Minimizing Conducted, Radiated, and System Noise for EMC/CE Compliance	40
Cable Part Numbers	85		
Card Part Number	85		

Minimum Load Inductance specifications	24	Auxiliary I/O Pins (Aux I/O Connector)	69
Motor Connector		Brake Output Connector	84
Mating Connector Part Numbers	48	Brake Output Pins (Feedback Connector)	61
Motor Function Relative to STO Input State	66	Control Supply Connector Wiring	31
Motor Power Output Connector	41	Digital Input 1 Connector [-EB1]	98
Brushless Motor Connections	42	Digital Input 2 Connector [-EB1]	99
DC Brush Motor Connections	45	Digital Input Pins (Aux I/O Connector)	79
Mating Connector Part Numbers	41	Digital Output 1 Connector [-EB1]	95
Pinout	41	Digital Output Pins (Aux I/O Connector)	76
Stepper Motor Connections	46	Encoder (Feedback Connector)	49
Three Phase Stepper Motor Connections	47	Encoder Fault Input Pin (Feedback Connector)	57
Motor Supply Connections	32	End of Travel Limit Input Pins (Feedback Connector)	58
Motor Supply Connector	32	Feedback Connector	48
Wiring Specifications	32	Hall-Effect Feedback Pins (Feedback Connector)	55
Motor Type specification	24	High-Speed Input Pins (Aux I/O Connector)	81
Mounting and Cooling	26	Home Limit Input Pins (Feedback Connector)	58
Mounting Hardware	26	Motor Power Output Connector	41
Mounting Orientation	26	Primary Encoder (Feedback Connector)	49
Multi-Axis PSO Tracking	21	PSO Interface Connector [-EB1]	103
Multi-Axis PSO Tracking with the Sync Port	88	PSO Pins (Aux I/O Connector)	74
		STO Connector	62
		Thermistor Input Pin (Feedback Connector)	56
		Pollution	29
		Position Feedback in the Diagnostic Display	54
		Position Synchronized Output (Aux I/O Connector)	74
		Position Synchronized Output (PSO) Interface [-EB1]	103
		Positive Motor Direction	43
		Power Amplifier Bandwidth specification	24
		Power Requirements	25
		Preventative Maintenance	110
		Primary Encoder (Feedback Connector)	49
		Primary Encoder Pins on the Feedback Connector	49
		PSO	
		Isolated Output Sinks Current Schematic	104
		Isolated Output Sources Current Schematic	104
		Sync Port (multi axis tracking)	88
		TTL Outputs Schematic	104
		PSO (Aux I/O Connector)	74
		PSO Connector [-EB1] Mating Connector Part Numbers	103
		PSO Interface Connector Pinout [-EB1]	103
		PSO Output Sources	74
		PSO Pins (Aux I/O Connector)	74
		PSO Specifications (Aux I/O Connector)	74
		PSO Specifications [-EB1]	103
N			
Nominal Motor Operating Voltages / Required AC Voltages	33		
O			
Operation	29		
Overview	19		
P			
packing list	15		
PC Configuration and Operation Information	92		
Phasing			
DC Brush Motor	45		
End of Travel Limits	60		
Powered Brushless Motor	43		
Stepper Motor	46-47		
Unpowered Brushless Motor/Feedback	44		
Pinout			
Analog Input Connector [-EB1]	102		
Analog Input Pins (Aux I/O Connector)	83		
Analog Output Connector [-EB1]	101		
Analog Output Pins (Aux I/O Connector)	82		
Auxiliary I/O Connector	68		

PSO Tracking		Sine Wave Encoder (Feedback Connector)	52
Sync Port	88	Square Wave Encoder (Feedback Connector)	50,70
PWM Switching Frequency specifications	24	STO Electrical Specifications	63
		Unit Weight	26
		Square Wave Encoder	50
		Square Wave Encoder (Auxiliary I/O Connector)	70
		Square Wave Encoder Inputs Schematic (Aux I/O Connector)	70
		Square Wave Encoder Schematic (Feedback Connector)	50
		Square Wave Encoder Specifications (Feedback Connector)	50,70
		SSI absolute encoder	51,71
		Stepper Motor Configuration	46
		Stepper Motor Connections (Motor Power Output Connector)	46
		Stepper Motor Phasing	46-47
		STO	62
		Connector Pinout	62
		Diagnostics	67
		Electrical Specifications	63
		External Delay Timer	65
		Functional Description	65
		Mating Connector Part Numbers	62
		Motor Function Relative to the STO Input State	66
		Signal Delay	66
		Standards	64
		Standards Data	64
		Startup Validation Testing	66
		Timing	67
		Typical Configuration	63
		Storage	15
		Sync-Related Commands	88
		Sync Port	
		PSO Tracking	88
		Sync Port Cables	88
		Sync Ports	88
		System part number	15
		System Power Requirements	25
		T	
		Table of Contents	3
		Temperature	29
		Thermistor Input (Feedback Connector)	56
		Thermistor Input Pin on the Feedback Connector	56
		Thermistor Input Schematic	56
		Three Phase Stepper Motor Configuration	47
Real-Time Clock Requirements	25		
Revision History	115		
RS-422 Encoder Specifications (Feedback Connector)	50,70		
RS-422 Line Driver Encoder	50		
RS-422 Line Driver Encoder (Auxiliary I/O Connector)	70		
		S	
Safe Torque Off Input (STO)	62		
Safety Procedures and Warnings	13		
SCCR	24		
serial data stream	51,71		
serial number	15		
Sine Wave Encoder (Aux Connector)	72		
Sine Wave Encoder (Auxiliary I/O Connector)	52		
Sine Wave Encoder Phasing Reference Diagram	72		
Sine Wave Encoder Schematic (Auxiliary I/O Connector)	73		
Sine Wave Encoder Specifications (Auxiliary I/O Connector)	72		
Sine Wave Encoder Specifications (Feedback Connector)	52		
Specifications			
Absolute Encoder (Auxiliary I/O Connector)	71		
Absolute Encoder (Feedback Connector)	51		
Analog Encoder (Auxiliary I/O Connector)	72		
Analog Encoder (Feedback Connector)	52		
Analog Input 0 (Aux I/O Connector)	83		
Analog Output 0 (Aux I/O Connector)	82		
Analog Outputs [-EB1]	101		
Brake Control Relay	61		
Control Board Fuses	111		
Differential Analog Inputs [-EB1]	102		
Digital Inputs (Aux I/O Connector)	79		
Digital Inputs [-EB1]	98		
Digital Outputs (Aux I/O Connector)	76		
Digital Outputs [-EB1]	94		
High-Speed Inputs	81		
Motor Supply Connector Wiring	32		
PSO (Aux I/O Connector)	74		
PSO [-EB1]	103		
RS-422 Encoder (Feedback Connector)	50,70		
Sine Wave Encoder (Auxiliary I/O Connector)	72		

Three Phase Stepper Motor Connections (Motor Power Output Connector)	47
TM3	33
TM5	33
Transformer Options	33
Travel Limit Input (Feedback Connector)	58
TTL Outputs Schematic (PSO)	104
TV0.3-28	33
TV0.3-28-56-ST Transformer	33
TV0.3-28-56-ST Transformer (160 VDC Bus)	36
TV0.3-28-56-ST Transformer (40 VDC Bus)	34
TV0.3-28-56-ST Transformer (80 VDC Bus)	35
TV0.3-28 Transformer (40 VDC Bus)	37
TV0.3-56	33
TV0.3-56 Transformer (80 VDC Bus)	38
Two Axis Joystick Interface	106
Two Axis Joystick Interface (to the I/O board of two drives)	107
Typical STO Configuration	63

U

Unit Weight	26
Use	29
User Power Supply Output specification	24

W

Warranty and Field Service	113
Wire Colors for Aerotech-Supplied Brushless Motor Cables	42
Wire Colors for Aerotech-Supplied DC Brush Motor Cables	45
Wire Colors for Aerotech-Supplied Stepper Motor Cables	46

This page intentionally left blank.