

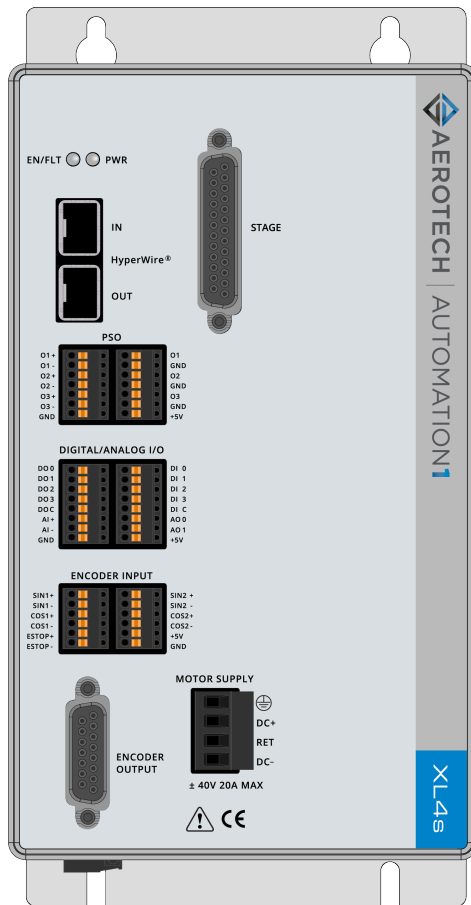

Automation1 XL4s High-Performance Voice-Coil Drive

HARDWARE MANUAL

Revision 2.09



GLOBAL TECHNICAL SUPPORT

Go to the [Global Technical Support Portal](#) for information and support about your Aerotech, Inc. products. The website supplies software, product manuals, Help files, training schedules, and PC-to-PC remote technical support. If necessary, you can complete Product Return (RMA) forms and get information about repairs and spare or replacement parts. To get help immediately, contact a service office or your sales representative. Include your customer order number in your email or have it available before you call.

This manual contains proprietary information and may not be reproduced, disclosed, or used in whole or in part without the express written permission of Aerotech, Inc. Product names mentioned herein are used for identification purposes only and may be trademarks of their respective companies.

Copyright © 2018-2024, Aerotech, Inc., All rights reserved.



Table of Contents

Automation1 XL4s High-Performance Voice-Coil Drive	1
Table of Contents	3
List of Figures	4
List of Tables	5
EU Declaration of Conformity	6
UKCA Declaration of Conformity	7
Korean Certification	8
Agency Approvals	9
Safety Procedures and Warnings	10
Handling and Storage	12
Installation Overview	13
Chapter 1: XL4s Overview	15
1.1. Feature Summary	16
1.2. Ordering Options	16
1.3. Functional Block Diagram	17
1.4. Electrical Specifications	18
1.5. Mechanical Specifications	19
1.5.1. Mounting and Cooling	19
1.5.2. Dimensions	20
1.6. Environmental Specifications	21
1.7. Drive and Software Compatibility	21
Chapter 2: Installation and Configuration	23
2.1. Input Power Connections	24
2.1.1. Control Supply Connector	24
2.1.2. Motor Supply Connector	25
2.1.3. External Power Supply Options	26
2.1.4. Minimizing Noise for EMC/CE Compliance	27
2.2. HyperWire Interface	28
2.3. Position Synchronized Output Connector	29
2.4. Encoder Output Connector	31
2.5. Stage Motor and Feedback Connector	33
2.5.1. Analog Encoder Inputs	34
2.6. Digital and Analog I/O Connectors	35
2.6.1. Digital Outputs	36
2.6.2. Digital Inputs	38
2.6.3. Analog Outputs	39
2.6.4. Analog Inputs (Differential)	40
2.7. Encoder Input Connectors	41
2.7.1. Emergency Stop Sense Input	43
2.8. Laser Output Polarity Switch	44
2.9. Sync Port	45
2.10. PC Configuration and Operation Information	45
Chapter 3: Maintenance	47
3.1. Preventative Maintenance	48
3.2. Board Assembly	49
Appendix A: Warranty and Field Service	51
Appendix B: Revision History	53
Index	55

List of Figures

Figure 1-1: XL4s High Performance Linear Amplifier	15
Figure 1-2: Functional Diagram	17
Figure 1-3: Dimensions	20
Figure 2-1: Control Supply Connections	24
Figure 2-2: Motor Supply Connections	25
Figure 2-3: Third-Party Power Supply Connection	26
Figure 2-4: Control and Motor Power Wiring using a TM3 Transformer	27
Figure 2-5: Encoder Outputs Schematic	31
Figure 2-6: PSO External Sync Input Schematic	32
Figure 2-7: Digital Outputs Connected in Current Sourcing Mode	37
Figure 2-8: Digital Outputs Connected in Current Sinking Mode	37
Figure 2-9: Digital Inputs Connected to Current Sourcing Devices	38
Figure 2-10: Digital Inputs Connected to Current Sinking Devices	38
Figure 2-11: Analog Outputs Schematic	39
Figure 2-12: Analog Inputs Schematic	40
Figure 2-13: Encoder Input Connector Encoder Connections	42
Figure 2-14: ESTOP Sense Input Schematic	43
Figure 2-15: Laser Output Polarity Switch Location	44
Figure 3-1: Control Board Assembly	49
Figure 3-2: Power Board Assembly	50

List of Tables

Table 1-1: Example Order and Ordering Options	16
Table 1-2: Electrical Specifications	18
Table 1-3: Mounting Specifications	19
Table 1-4: Environmental Specifications	21
Table 1-5: Drive and Software Compatibility	21
Table 2-1: Control Supply Connector Pinout	24
Table 2-2: Control Supply Mating Connector Ratings	24
Table 2-3: Motor Supply Connector Pinout	25
Table 2-4: Motor Supply Mating Connector Ratings	25
Table 2-5: HyperWire Card Part Number	28
Table 2-6: HyperWire Cable Part Numbers	28
Table 2-7: PSO Connector A Pinout	29
Table 2-8: PSO Connector B Pinout	29
Table 2-9: Mating Connector Part Numbers for the PSO Connectors	29
Table 2-10: PSO Specifications	30
Table 2-11: Encoder Output Connector Pinout	31
Table 2-12: Mating Connector Part Numbers for the Encoder Output Connector	31
Table 2-13: PSO External Sync Specifications	32
Table 2-14: Stage Motor and Feedback Connector Pinout	33
Table 2-15: Mating Connector Part Numbers for the Stage Motor and Feedback Connector	33
Table 2-16: Analog Encoder Input Specifications	34
Table 2-17: Digital and Analog I/O Connector A Pinout	35
Table 2-18: Digital and Analog I/O Connector B Pinout	35
Table 2-19: Mating Connector Part Numbers for the Digital / Analog I/O Connectors	35
Table 2-20: Digital Output Specifications	36
Table 2-21: Digital Output Pins on the Digital/Analog I/O A Connector	36
Table 2-22: Digital Input Specifications	38
Table 2-23: Digital Input Pins on the Digital/Analog I/O B Connector	38
Table 2-24: Analog Output Specifications	39
Table 2-25: Analog Output Pins on the Digital / Analog I/O B Connector	39
Table 2-26: Analog Input Specifications	40
Table 2-27: Analog Input Pins on the Digital / Analog I/O B Connector	40
Table 2-28: Encoder Input Connector Specifications	41
Table 2-29: Encoder Input Connector A Pinout	41
Table 2-30: Encoder Input Connector B Pinout	41
Table 2-31: Mating Connector Part Numbers for the Encoder Input Connector	41
Table 2-32: ESTOP Pins on the Encoder Input Connector	43
Table 2-33: Electrical Noise Suppression Devices	43
Table 2-34: Sync-Related Functions	45
Table 2-35: Sync Port Cables	45
Table 3-1: LED Description	47
Table 3-2: Troubleshooting	47
Table 3-3: Preventative Maintenance	48
Table 3-4: Control Board Fuse Specifications	49
Table 3-5: Power Board Fuse Specifications	50

EU Declaration of Conformity

Manufacturer Aerotech, Inc.
Address 101 Zeta Drive
Pittsburgh, PA 15238-2811
USA
Product XL4s
Model/Types All



This is to certify that the aforementioned product is in accordance with the applicable requirements of the following directive(s):

2014/35/EU	Low Voltage Directive
EU 2015/863	Directive, Restricted Substances (RoHS 3)

and has been designed to be in conformity with the applicable requirements of the following standard(s) when installed and used in accordance with the manufacturer's supplied installation instructions.

EN 61010-1:2010	Safety Requirements for Electrical Equipment
-----------------	--

**Authorized
Representative:**

A handwritten signature in blue ink, appearing to read 'Norbert Ludwig', is written over a light blue horizontal line.

/ Norbert Ludwig

Managing Director
Aerotech GmbH
Gustav-Weißkopf-Str. 18
90768 Fürth
Germany

**Engineer Verifying
Compliance**

A handwritten signature in black ink, appearing to read 'Alex Weibel', is written over a light blue horizontal line.

/ Alex Weibel

Aerotech, Inc.
101 Zeta Drive
Pittsburgh, PA 15238-2811
USA
Date 6/5/2024

UKCA Declaration of Conformity

Manufacturer Aerotech, Inc.
Address 101 Zeta Drive
Pittsburgh, PA 15238-2811
USA
Product XL4s
Model/Types All



To which this declaration relates, meets the essential health and safety requirements and is in conformity with the relevant UK Legislation listed below:

Electrical Equipment (Safety) Regulations 2016
Hazardous Substances in Electrical and Electronic Equipment Regulations 2012

Using the relevant section of the following UK Designated Standards and other normative documents when installed in accordance with the installation instructions supplied by the manufacturer.

EN 61010-1:2010 Safety Requirements for Electrical Equipment

Authorized Representative:

A handwritten signature in black ink, appearing to read 'Simon Smith'.

/ Simon Smith

Managing Director
Aerotech Ltd
The Old Brick Kiln, Ramsdell, Tadley
Hampshire RG26 5PR
UK

Engineer Verifying Compliance

A handwritten signature in black ink, appearing to read 'Alex Weibel'.

/ Alex Weibel

Aerotech, Inc.
101 Zeta Drive
Pittsburgh, PA 15238-2811
USA
6/5/2024

Date

Korean Certification



Registration of Broadcasting and Communication Equipments

It is verified that the foregoing equipment has been registered under the Clause 3, Article 58-2 of the radio Waves Act.

Agency Approvals

The XL4s drives have been tested by the following NRTL(s) and have been certified to the standards that follow:

Approval:	CUS NRTL
Approving Agency:	TÜV SÜD America Inc.
Certificate #:	U8 068995 0031
Standards:	CAN/CSA C22.2 No. 61010-1:2012 , EN 61010-1:2010, UL 61010-1:2012



Visit <https://www.tuev-sued.de/product-testing/certificates> to view Aerotech's TÜV SÜD certificates. Type the certificate number listed above in the search bar or type "Aerotech" for a list of all Aerotech certificates.

Safety Procedures and Warnings



IMPORTANT: This manual tells you how to carefully and correctly use and operate the drive.

- Read all parts of this manual before you install or operate the drive or before you do maintenance to your system.
- To prevent injury to you and damage to the equipment, obey the precautions in this manual.
- All specifications and illustrations are for reference only and were complete and accurate as of the release of this manual. To find the newest information about this product, refer to www.aerotech.com.

If you do not understand the information in this manual, contact Aerotech Global Technical Support.



IMPORTANT: This product has been designed for light industrial manufacturing or laboratory environments. If the product is used in a manner not specified by the manufacturer:

- The protection provided by the equipment could be impaired.
- The life expectancy of the product could be decreased.

Safety notes and symbols are placed throughout this manual to warn you of the potential risks at the moment of the safety note or if you fail to obey the safety note.



The voltage can cause shock, burn, or death.



You are at risk of physical injury.
You could damage the drive.



A surface can be hot enough to burn you.



Your actions, the temperature of the system, or the condition of the atmosphere that surround the system could start a fire.



Components are sensitive to electrostatic discharge.



Unsecured cables could cause you to:

- trip and fall
- drag the product off of its mounting location
- damage the cable connections.



A blue circle symbol is an action or tip that you should obey. Some examples include:

- General tip
- Read the manual/section
- Wear protective safety equipment (eye protection, ear protection, gloves)
- If applicable, do not lift unassisted





DANGER: To decrease the risk of electrical shock, injury, death, and damage to the equipment, obey the precautions that follow.

1. Before you do maintenance to the equipment, disconnect the electrical power.
2. Restrict access to the drive when it is connected to a power source.
3. Do not connect or disconnect electrical components, wires, and cables while this product is connected to a power source.
4. Wait at least ten (10) minutes after removing the power supply before doing maintenance or an inspection. Otherwise, there is the danger of electric shock.
5. Supply each operator with the necessary protection from live electrical circuits.
6. Make sure that all components are grounded correctly and that they obey the local electrical safety requirements.
7. Install the necessary precautions to supply safety and protection to the operator.



DANGER: System travel can cause crush, shear, or pinch injuries. Restrict access to all motor and stage parts while your system is connected to a power source.



WARNING: To prevent damage to the equipment and decrease the risk of electrical shock and injury, obey the precautions that follow.

1. Make sure that all system cables are correctly attached and positioned.
2. Do not use the cables or the connectors to lift or move this product.
3. Use this product only in environments and operating conditions that are approved in this manual.
4. Only trained operators should operate this equipment.

Handling and Storage

Unpacking the drive



IMPORTANT: All electronic equipment and instrumentation is wrapped in antistatic material and packaged with desiccant. Ensure that the antistatic material is not damaged during unpacking.

Inspect the shipping container for any evidence of shipping damage. If any damage exists, notify the shipping carrier immediately.

Remove the packing list from the shipping container. Make sure that all the items specified on the packing list are contained within the package.

The documentation for the drive is on the included installation device. The documents include manuals, interconnection drawings, and other documentation pertaining to the system. Save this information for future reference. Additional information about the system is provided on the Serial and Power labels that are placed on the chassis.

The system serial number label contains important information such as the:

- Customer order number (please provide this number when requesting product support)
- Drawing number
- System part number

Handling



IMPORTANT: It is the responsibility of the customer to safely and carefully lift and move the drive.

- Be careful when you move or transport the drive.
- Refer to [Section 1.5. Mechanical Specifications](#) for dimensions and weight specifications.
- Retain the shipping materials for future use.
- Transport or store the drive in its protective packaging.



WARNING: Electrostatic Discharge (ESD) Sensitive Components!

You could damage the power supply or drives if you fail to observe the correct ESD practices. Wear an ESD wrist strap when you handle, install, or do service to the system assembly.

Storage

Store the drive in the original shipping container. If the original packaging included ESD protective packaging, make sure to store the drive in it. The storage location must be dry, free of dust, free of vibrations, and flat.

Refer to [Section 1.6. Environmental Specifications](#).

Installation Overview

This image shows the order in which to make connections and settings that are typical to the XL4s. If a custom interconnect drawing was supplied with your system, that drawing is on your Storage Device and shows as a line item on your Sales Order in the Integration section.

Figure 1: Installation Connection Overview

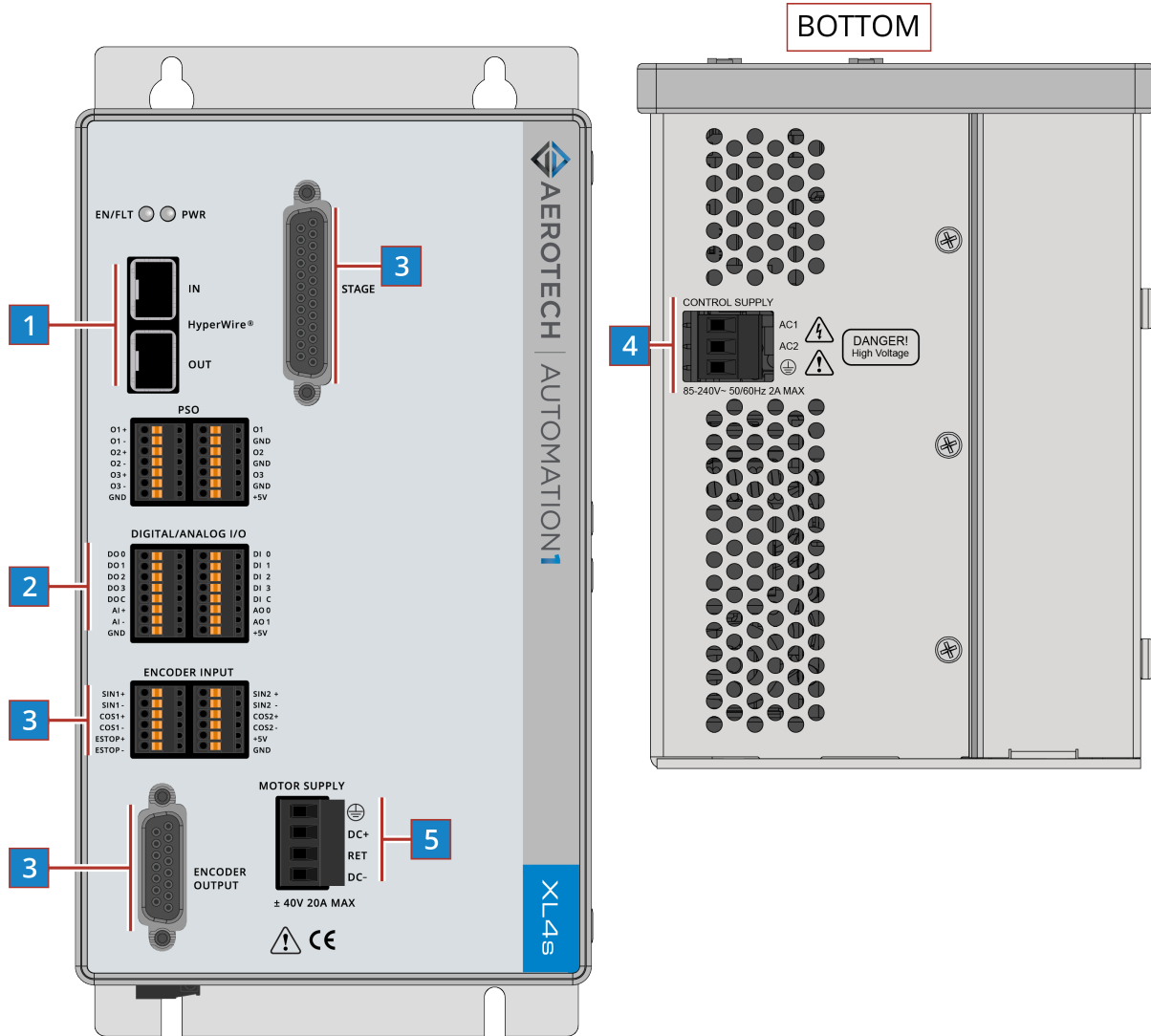

1	Connect a PC HyperWire port to the HyperWire In port.	Section 2.2.
2	Connect the Digital/Analog I/O.	Section 2.6.
3	Connect the Stage motor and feedback connector.	Section 2.5.
4	Connect to the Control Supply connector.	Section 2.1.1.
5	Connect to the Motor Supply connector.	Section 2.1.2.

This page intentionally left blank.

Chapter 1: XL4s Overview

The XL4s is a high-performance linear amplifier designed to eliminate the non-linearities common with PWM amplifiers. The drive provides deterministic behavior, auto-identification, and easy software setup.

Figure 1-1: XL4s High Performance Linear Amplifier

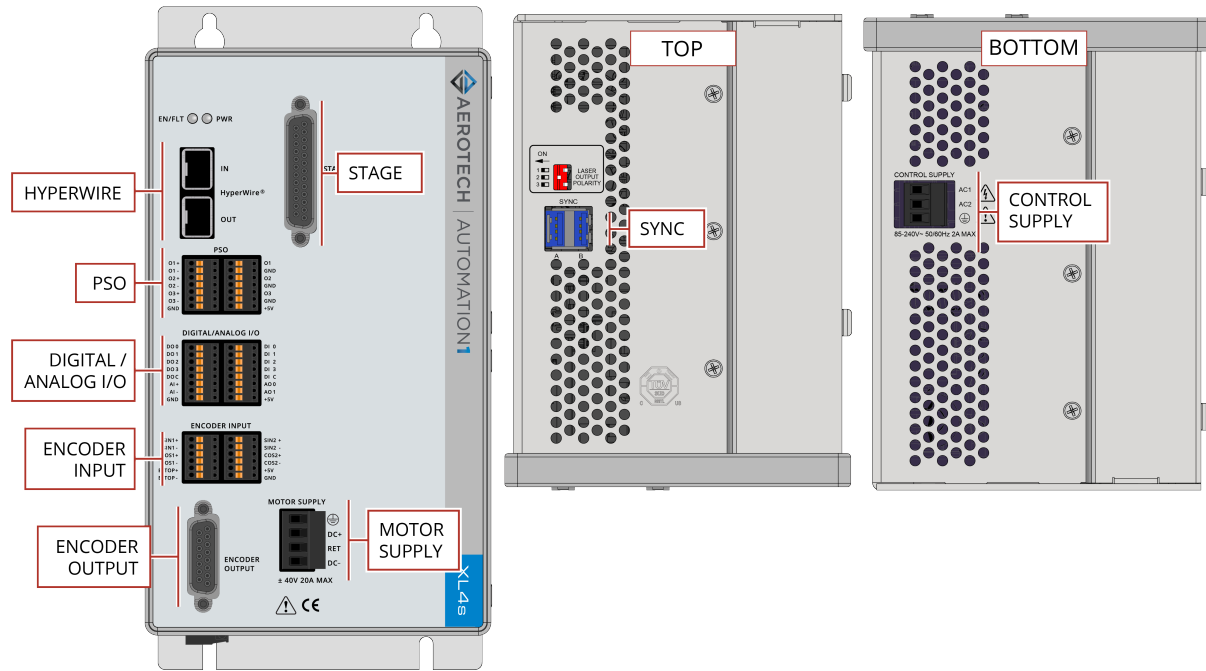

1.1. Feature Summary

- Control Supply: 85-240 VAC; 50-60 Hz control supply ([Section 2.1.1.](#))
- Motor Supply: ± 40 VDC max motor supply ([Section 2.1.2.](#))
- 200 kHz Servo Loop Update Rate
- Communication:
 - Two HyperWire communication channels (one per axis) ([Section 2.2.](#))
 - Two Sync ports ([Section 2.9.](#))
- Outputs:
 - Four optically-isolated digital outputs; 5-24V ([Section 2.6.1.](#))
 - Two 16-bit single-ended analog outputs; ± 10 V ([Section 2.6.3.](#))
- Inputs:
 - One auxiliary channel of 40 MHz line driver quadrature encoder inputs ([Section 2.7.](#))
 - Four optically-isolated digital inputs; 5-24V ([Section 2.6.2.](#))
 - One 16-bit differential analog input; ± 10 V ([Section 2.6.4.](#))
- ESTOP: Dedicated 5-24V Emergency Stop sense input ([Section 2.7.1.](#))
- Position Synchronized Outputs (PSO):
 - Generate outputs synchronized to feedback positioning ([Section 2.3.](#))
 - Three-axis Part-Speed PSO Firing: Part-Speed PSO commands high-speed, low-latency output pulses based on the commanded vector velocity. Refer to the online help for more information.
 - Multi-Axis PSO Tracking: To track multiple axes...
 - with Aerotech drives, use the Sync Ports ([Section 2.9.](#))
 - with non-Aerotech drives and square wave encoder signals, use the Encoder Input A/B connectors ([Section 2.7.](#))
 - with non-Aerotech drives and sine or square wave encoder signals, use the Stage connector ([Section 2.5.](#))

1.2. Ordering Options

Table 1-1: Example Order and Ordering Options

Example	
Automation1-XL4s-20	
Options	
Automation1 Amplifier	
-XL4s	Single-Phase Linear Amplifier
Current	
-20	20 A peak; 5 A continuous

1.3. Functional Block Diagram

The block diagram that follows shows a summary of the connector signals.

Figure 1-2: Functional Diagram

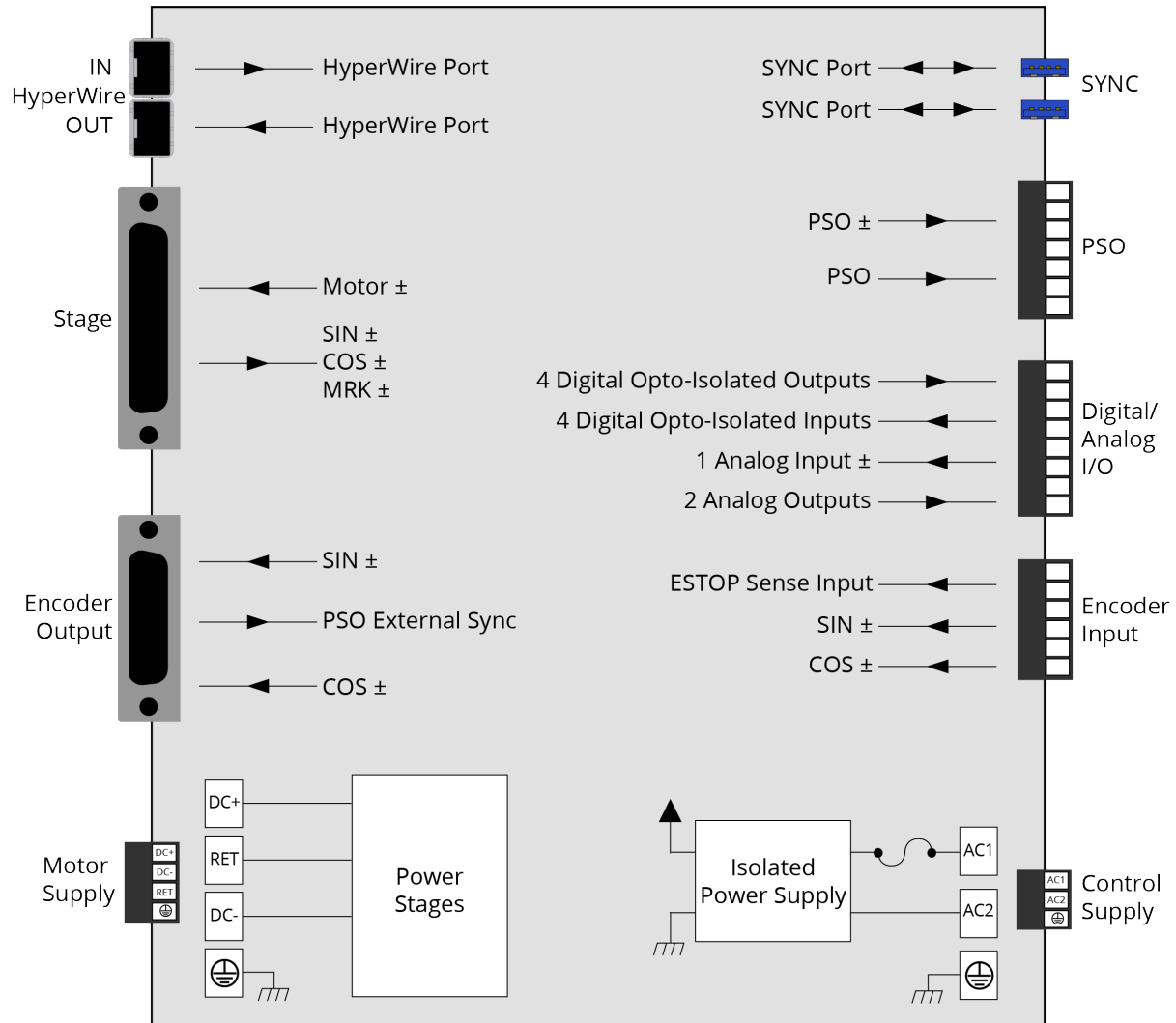

1.4. Electrical Specifications

Table 1-2: Electrical Specifications

Description		XL4s
Motor Supply	Input Voltage	±40 VDC (max)
	Input Current (continuous)	10 A
Control Supply	Input Voltage	85-240 VAC
	Input Frequency	50-60 Hz
	Inrush Current	16 A
	Input Current	0.35 A (max)
Output Voltage		76 V
Peak Output Current		20 A
Continuous Output Current		5 A
Minimum Load Resistance		0.5 Ω
User Power Supply Output		5 VDC (@ 500 mA)

1.5. Mechanical Specifications

1.5.1. Mounting and Cooling

The drive must be installed in an enclosed control cabinet suitable for installation of power equipment. A minimum enclosure rating of IP54 is required to comply with safety standards. Make sure that there is sufficient clearance surrounding the drive for free airflow and for the routing of cables and connections. Consideration for items such as line reactors, line filters, and motor chokes or inductance should be made during the initial cabinet design phase.

Table 1-3: Mounting Specifications

		XL4s
Customer-Supplied Enclosure		IP54 Compliant
Weight		3.0 kg
Mounting Hardware		M4 [#8] screws (four locations, not included)
Mounting Orientation		Vertical (typical)
Dimensions		Refer to Section 1.5.2. Dimensions
Minimum Clearance	Airflow	~25 mm
	Connectors	~100 mm
Operating Temperature		Refer to Section 1.6. Environmental Specifications
Drive IP Rating		IP20

1.5.2. Dimensions

Figure 1-3: Dimensions

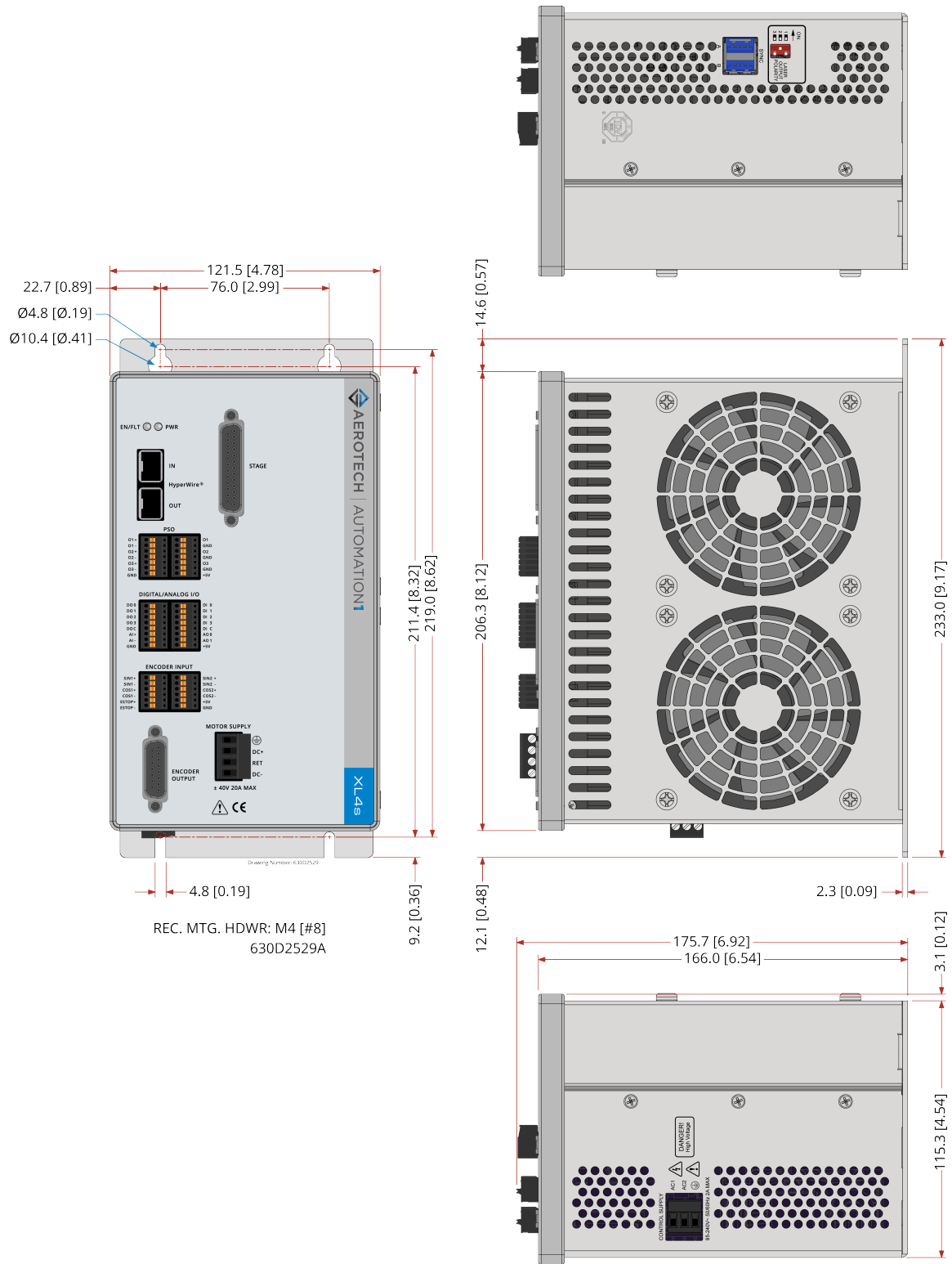

1.6. Environmental Specifications

The environmental specifications are listed below.

Table 1-4: Environmental Specifications

Temperature	Operating: 0 °C to 40 °C (32 °F to 104 °F)
	Maximum Surrounding Air: 40 °C (104 °F)
	Storage: -30 °C to 85 °C (-22 °C to 185 °F)
Humidity Non-condensing	The maximum relative humidity is 80% for temperatures that are less than 31 °C and decreases linearly to 50% relative humidity at 40 °C.
Operating Altitude	0 m to 2,000 m (0 ft to 6,562 ft) above sea level.
Pollution	Pollution Degree 2 Typically only nonconductive pollution occurs.
Operation	Use only indoors

1.7. Drive and Software Compatibility

This table shows the available drives and which version of the software first supported each drive. In the **Last Software Version** column, drives that show a specific version number are not supported after that version.

Table 1-5: Drive and Software Compatibility

Drive Type	Software	First Software Version	Last Software Version
XL4s	Automation1	1.2.0	Current
	A3200	6.04	Current

This page intentionally left blank.

Chapter 2: Installation and Configuration

The sections in this chapter include details on how to set up the electrical and safety components of your system. Obey all safety warnings, including those in [Safety Procedures and Warnings](#).

2.1. Input Power Connections

The drive has two input power connectors. One connector is for AC control power and the other connector is for DC motor power. For a full list of electrical specifications, refer to [Section 1.4](#).

2.1.1. Control Supply Connector



DANGER: Shock and Fire Hazard



Electrical wiring must be designed and installed in accordance with local electrical safety regulations to prevent the risk of fire and electrical shock.



IMPORTANT: To operate correctly, this product must have a power supply connected to the Motor Supply and a power supply connected to the Control Supply.

The Control Supply input supplies power to the communications and logic circuitry of the drive. The AC1 input and the AC2 input are connected to fuses inside the drive. Refer to [Table 3-5](#) for fuse values and part numbers.

The Control Supply contains an internal filter. It is not necessary to use an external filter for CE compliance.



DANGER: Verify that all ground connections are installed correctly before you apply power to the XL4s.

Figure 2-1: Control Supply Connections

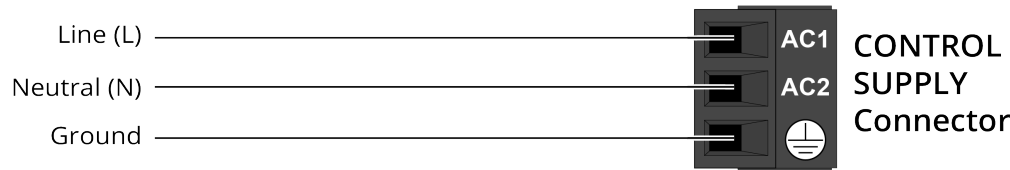

Table 2-1: Control Supply Connector Pinout

Pin	Description
AC1	Line Input: 85 - 240 Volt AC Input Range
AC2	Neutral (0V) or 85 - 240 Volt AC Input Range
	Protective Ground

(1) The wire insulation is rated for 300 V.

Table 2-2: Control Supply Mating Connector Ratings

Specification	Description
Type	3-Pin Terminal Block
Part Numbers	Aerotech: ECK02388
	Phoenix: 1756272
Conductor Cross Section	One conductor, stranded with ferrule and plastic sleeve 14...22 AWG (0.25...2.5 mm ²)
	Two conductors (same cross-section), stranded, twin ferrule with plastic sleeve 16...20 AWG (0.5...1.5 mm ²)
Tightening Torque	0.5...0.6 N·m
Conductor Insulation Strip Length	7 mm (0.25 in)

(1) Refer to the manufacturer website for additional information.

2.1.2. Motor Supply Connector



DANGER: Shock and Fire Hazard!

Electrical wiring must be designed and installed in accordance with local electrical safety regulations to prevent the risk of fire and electrical shock.



IMPORTANT: To operate correctly, this product must have a power supply connected to the Motor Supply and a power supply connected to the Control Supply.

Motor power is applied to the XL4s at the four terminals of the Motor Supply connector. The DC+ input and the DC- input are connected to fuses inside the drive. Refer to [Table 3-5](#) for fuse values and part numbers.



DANGER: Shock Hazard! To prevent the risk of electric shock, do not operate the XL4s without a ground connection.

Figure 2-2: Motor Supply Connections

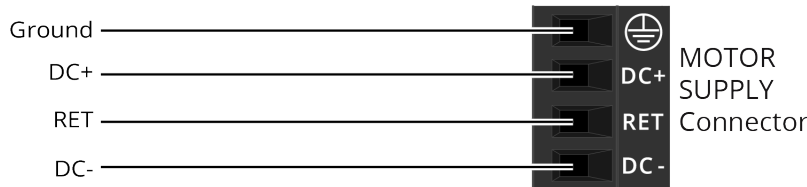

Table 2-3: Motor Supply Connector Pinout

Pin	Description
DC+	+40 VDC Input Range
RET	Return for DC Input
DC-	-40 VDC Input Range
	Protective Ground - 2.5 mm ² / 14 AWG min conductor size

(1)The wire insulation is rated for 300 V.

Table 2-4: Motor Supply Mating Connector Ratings

Specification		Description
Type		4-Pin Terminal Block
Part Numbers		Aerotech: ECK02407 Phoenix: 1758843
Conductor Cross Section	One conductor, stranded with ferrule and plastic sleeve	14...22 AWG (0.25...2.5 mm ²)
	Two conductors (same cross-section), stranded, twin ferrule with plastic sleeve	16...20 AWG (0.5...1.5 mm ²)
Tightening Torque		0.5...0.6 N·m
Conductor Insulation Strip Length		7 mm (0.25 in)

(1) Refer to the manufacturer website for additional information.

2.1.3. External Power Supply Options

You must connect the Motor Supply to a bipolar power supply. Aerotech recommends that you use an Aerotech TM3 transformer which can supply power to a maximum of four controllers (Figure 2-4).

As an alternative to a bipolar power supply, you can use two third-party power supplies but they must obey these conditions (Figure 2-3).

- The output of each power supply must not be ground referenced.
- The output of each power supply must be specified to be used in positive or negative polarity.

The XL4s controller can source 10 A peak current to each motor. This current must be supplied by the external power supply. A switching power supply must be rated for the peak current requirement of the system because the switching power supply might shut down if it is overloaded.

Figure 2-3: Third-Party Power Supply Connection

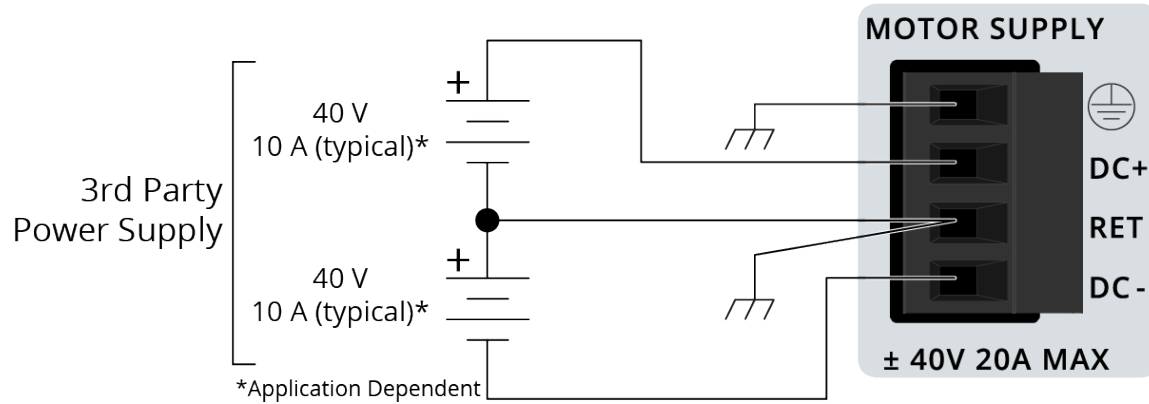
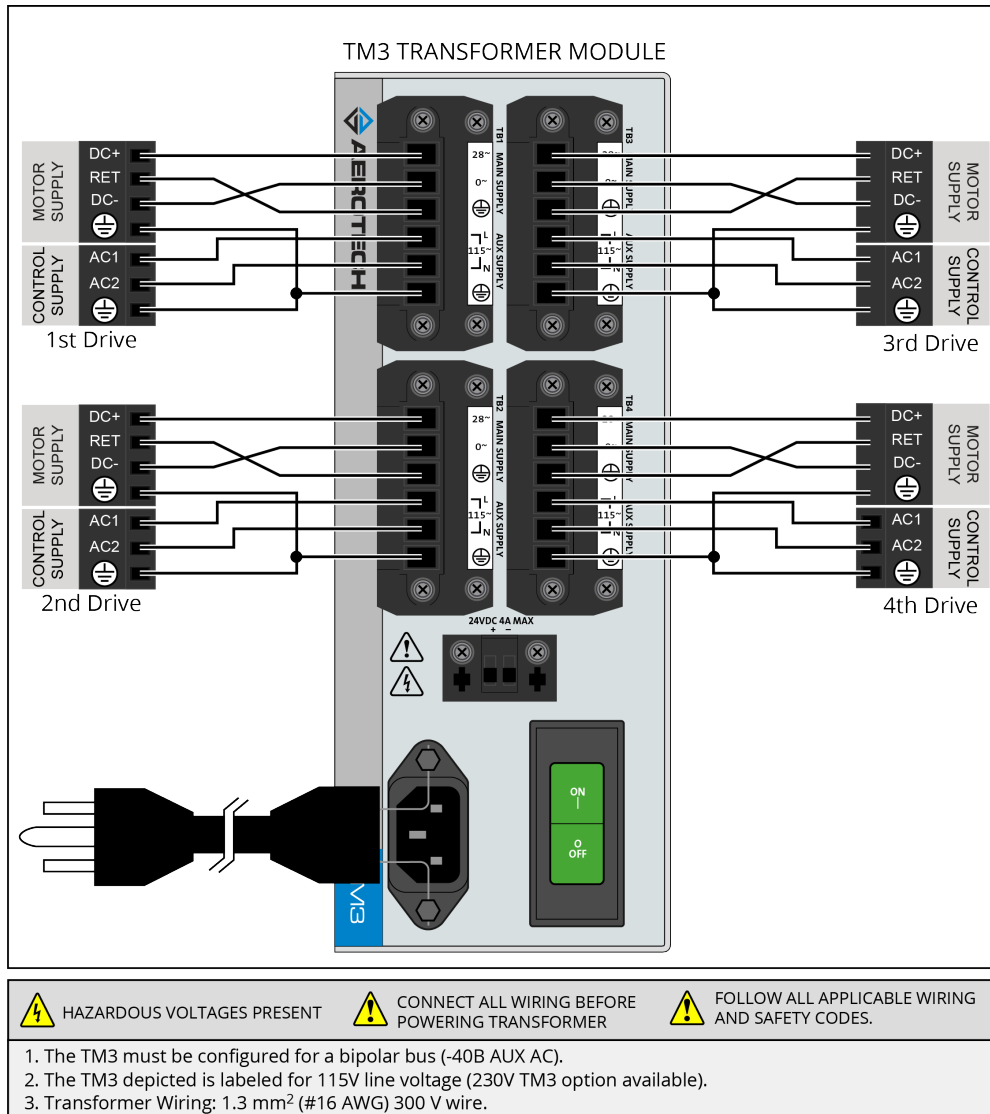

Figure 2-4: Control and Motor Power Wiring using a TM3 Transformer



2.1.4. Minimizing Noise for EMC/CE Compliance



IMPORTANT: The XL4s is a component designed to be integrated with other electronics. EMC testing must be conducted on the final product configuration.

To reduce electrical noise, observe the following motor feedback and input power wiring techniques.

1. Separate motor and power wiring from encoder and I/O wiring.
2. Mount drives, power supplies, and filter components on a conductive panel. Mount line filters close to the drive to keep the wire length between the drive and filter to a minimum. Use a line filter, such as Aerotech's UFM-ST, on the Control Supply AC inputs.

The following additional changes could be required for EMC compliance and are recommended during initial EMC system evaluation.

1. Add a clamp-on ferrite to the motor feedback cable close to the drive.
[Aerotech PN ECZ02348, Fair-rite PN 0446167281]
2. Add a ferrite core to the UFM-ST AC input wires. Wrap the AC wires and ground wire around the core one time.
[Ferrite core: Aerotech PN ECZ02350, Fair-rite PN 2646102002]

2.2. HyperWire Interface

The HyperWire bus is the high-speed communications connection from the controller. It operates at 2 gigabits per second. The controller sends all command and configuration information through the HyperWire bus. This device consumes two of the available axes of control on the HyperWire communication network. Refer to your Automation1-iSMC license for the number of available HyperWire axes.

HyperWire cables can be safely connected to or disconnected from a HyperWire port while the PC and/or drive is powered on. However, any changes to the HyperWire network topology will disrupt communication and you must reset the controller to re-establish communication.



WARNING: Do not connect or disconnect HyperWire cables while you are loading firmware or damage to the drives may occur.

Table 2-5: HyperWire Card Part Number

Part Number	Description
HYPERWIRE-PCIE	HyperWire adapter, PCIe x4 interface

Table 2-6: HyperWire Cable Part Numbers

Part Number	Description
HYPERWIRE-AO10-5	HyperWire cable, active optical, 0.5 m
HYPERWIRE-AO10-10	HyperWire cable, active optical, 1.0 m
HYPERWIRE-AO10-30	HyperWire cable, active optical, 3.0 m
HYPERWIRE-AO10-50	HyperWire cable, active optical, 5.0 m
HYPERWIRE-AO10-200	HyperWire cable, active optical, 20.0 m

2.3. Position Synchronized Output Connector

Program the Position Synchronized Output (PSO) to generate an output that is synchronized to the feedback position of an axis. PSO is typically used to fire a laser or trigger an external hardware device. The XL4s supports three-axis PSO in Automation1 versions 2.4.0+. The XL4s supports dual-axis PSO in A3200 and Automation1 versions before 2.4.0.

A PSO firing event can be triggered from a feedback channel or from a software trigger. You can get quadrature signals from feedback channels and PSO firing event signals after a PSO firing event occurs. When the PSO generates pulses, minimum latency occurs between the trigger condition and the output.

Aerotech recommends that you use an RS-422 line receiver or an opto-isolator if your system:

- Uses cables with long lengths in work areas where a lot of electrical noise occurs.
- Uses high-frequency pulse transmission.

For best performance, put the RS-422 line receiver or the opto-isolator near the electronics that receive the PSO output pulse.

Table 2-7: PSO Connector A Pinout

Pin #	Label	Description	In/Out/Bi	Connector
1	O1+	PSO Output	Output	
2	O1-	PSO Output	Output	
3	O2+	Reserved	N/A	
4	O2-	Reserved	N/A	
5	O3+	Reserved	N/A	
6	O3-	Reserved	N/A	
7	GND	Ground	N/A	

Table 2-8: PSO Connector B Pinout

Pin #	Label	Description	In/Out/Bi	Connector
1	O1	PSO Output (5V TTL)	Output	
2	GND	Ground	N/A	
3	O2	Reserved	N/A	
4	GND	Ground	N/A	
5	O3	Reserved	N/A	
6	GND	Ground	N/A	
7	+5V	5 Volt Power Supply (500 mA)	Output	

Table 2-9: Mating Connector Part Numbers for the PSO Connectors

Specification		Description
Type		7-Pin Terminal Block
Part Numbers		Aerotech: ECK02403
		Phoenix: 1908114
Conductor Cross Section	Solid or stranded	20...26 AWG (0.14...0.5 mm ²)
	Stranded, with ferrule, without plastic sleeve	20...24 AWG (0.25...0.5 mm ²)
Conductor Insulation Strip Length		8 mm (5/16 in)
(1) Refer to the manufacturer website for additional information.		

Table 2-10: PSO Specifications

Specification		Value
Maximum PSO Output (Fire) Frequency	TTL	12.5 MHz
	Isolated	5 MHz
Output Latency [Fire event to output change]	TTL	60 ns
	Isolated	160 ns
1. Signals in excess of this rate will cause a loss of PSO accuracy		

2.4. Encoder Output Connector

The Encoder Output interface echos the encoder signals out of the axis.

Table 2-11: Encoder Output Connector Pinout

Pin	Description	In/Out/Bi	Connector
1	SIN-	Output	
2	Reserved	N/A	
3	COS-	Output	
4	Reserved	N/A	
5	Reserved	N/A	
6	Reserved	N/A	
7	PSO External Sync	Input	
8	+5V (500 mA max)	Output	
9	SIN+	Output	
10	Reserved	N/A	
11	COS+	Output	
12	Reserved	N/A	
13	Reserved	N/A	
14	Reserved	N/A	
15	Ground	N/A	

Table 2-12: Mating Connector Part Numbers for the Encoder Output Connector

Specification	15-Pin Solder Cup	Backshell
Aerotech Part Number	ECK00100	ECK01022
Amphenol Part Number ⁽¹⁾	DA15P064TXLF	17E-1725-2
Maximum Wire Size	20 AWG (0.5 mm ²)	N/A

(1) Refer to the manufacturer website for additional information.

Figure 2-5: Encoder Outputs Schematic

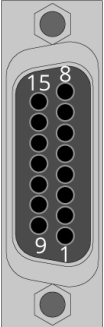
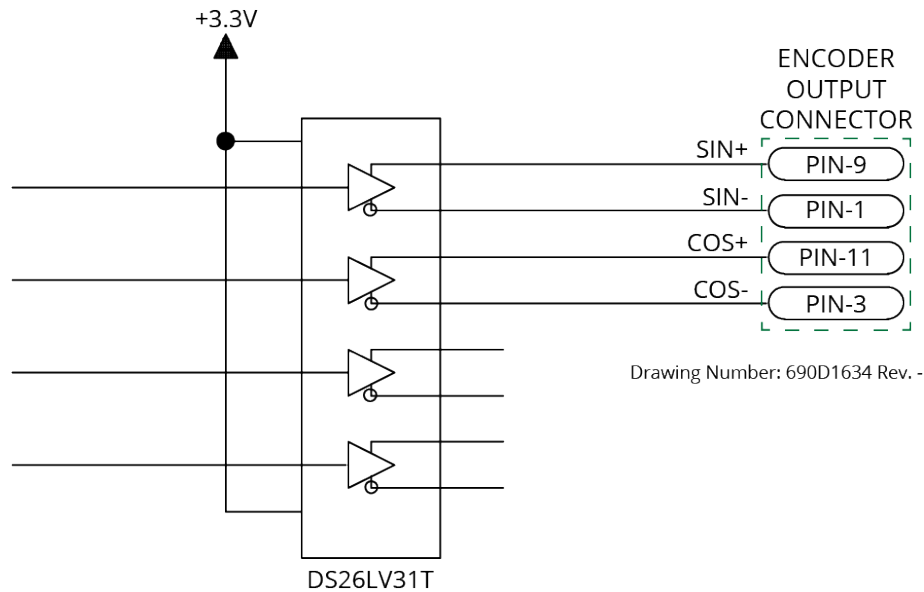

You can use the external PSO synchronization functions [A3200: PSOOUTPUT PULSE EXTSYNC command] to synchronize waveform generation with an external synchronization signal. When you activate this feature, the PSO Waveform module will not generate the configured waveform when an output event is received until the rising edge of the synchronization signal occurs.

Table 2-13: PSO External Sync Specifications

Specification	Value
Voltage	3.3 VDC
Frequency	25 MHz Maximum
On Time	20 ns Minimum

Figure 2-6: PSO External Sync Input Schematic

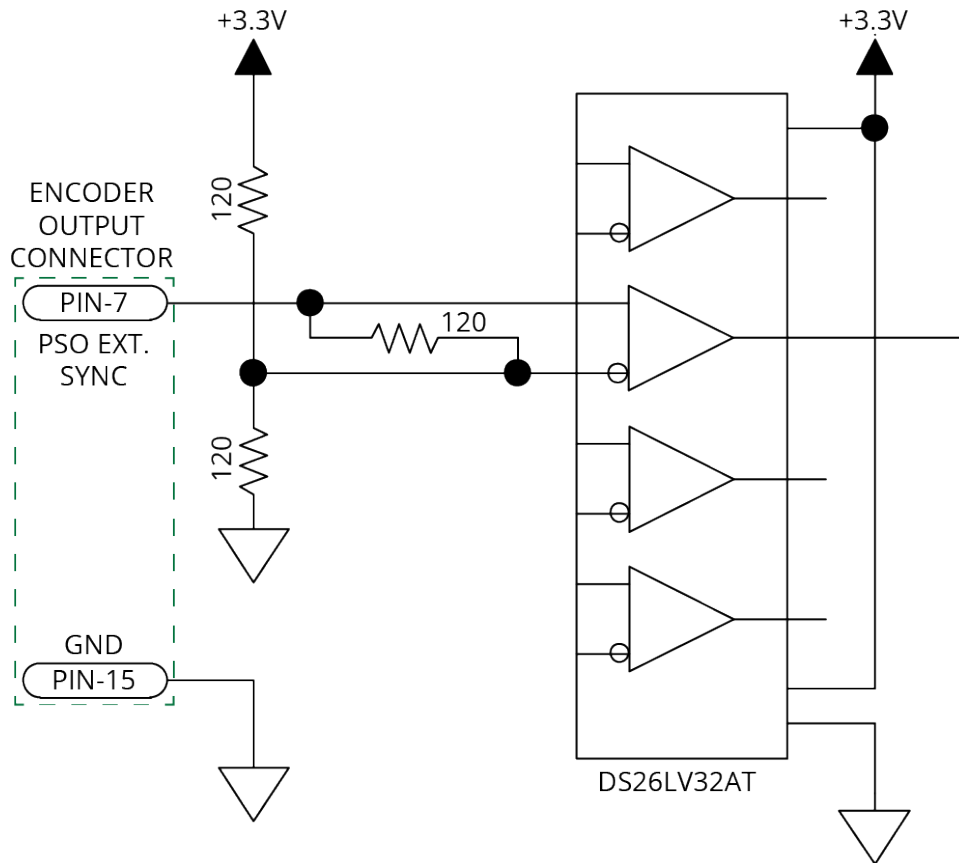

2.5. Stage Motor and Feedback Connector

You can only use the XL4s to control a DC Brush motor.

Table 2-14: Stage Motor and Feedback Connector Pinout

Pin	Description	In/Out/Bi	Pin Location
1	Sine +	Input	
2	Cosine +	Input	
3	Encoder Ground	N/A	
4	Reserved	N/A	
5	Reserved	N/A	
6	Reserved	N/A	
7	Marker +	Input	
8	Encoder Power (+5V, 500 mA)	Output	
9	Reserved	N/A	
10	Flash Configuration	Input	
11	Frame Ground	N/A	
12	Motor +	Output	
13	Motor +	Output	
14	Sine -	Input	
15	Cosine -	Input	
16	Encoder Ground	N/A	
17	Reserved	N/A	
18	Reserved	N/A	
19	Reserved	N/A	
20	Marker -	Input	
21	Encoder Ground	N/A	
22	Reserved	N/A	
23	Frame Ground	N/A	
24	Motor -	Output	
25	Motor -	Output	

Table 2-15: Mating Connector Part Numbers for the Stage Motor and Feedback Connector

Specification	25-Pin Solder Cup	Backshell
Aerotech Part Number	ECK00101	ECK00656
Amphenol Part Number ⁽¹⁾	DB25P064TXLF	17E-1726-2
Maximum Wire Size	20 AWG (0.5 mm ²)	N/A
⁽¹⁾ Refer to the manufacturer website for additional information.		

2.5.1. Analog Encoder Inputs

The XL4s has one analog encoder input channel. The XL4s uses this input channel for position feedback. Use Encoder Tuning [A3200: Feedback Tuning] to adjust the value of the gain, offset, and phase balance controller parameters to get the best performance. For more information, refer to the Help file.

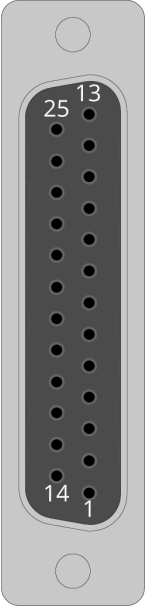
Table 2-16: Analog Encoder Input Specifications

Specification	Value
Input Frequency (max)	500 kHz
Input Amplitude ⁽¹⁾	0.6 to 1.2 Vpk-pk
Interpolation Factor (max)	65,536
Input Common Mode	1.5 to 3.5 VDC

(1) Any single-ended encoder signal measured with respect to ground.

2.6. Digital and Analog I/O Connectors

This connector has four digital, optically-isolated outputs, four digital, optically-isolated inputs, one differential analog input, and two analog outputs.

Table 2-17: Digital and Analog I/O Connector A Pinout

Pin #	Label	Description	In/Out/Bi	Connector
1	DO0	Digital Output 0 (Optically-Isolated)	Output	
2	DO1	Digital Output 1 (Optically-Isolated)	Output	
3	DO2	Digital Output 2 (Optically-Isolated)	Output	
4	DO3	Digital Output 3 (Optically-Isolated)	Output	
5	DOC	Digital Output Common	Output	
6	AI+	Analog Input +	Input	
7	AI-	Analog Input -	Input	
8	GND	Ground	N/A	

Table 2-18: Digital and Analog I/O Connector B Pinout

Pin #	Label	Description	In/Out/Bi	Connector
1	DI0	Digital Input 0 (Optically-Isolated)	Input	
2	DI1	Digital Input 1 (Optically-Isolated)	Input	
3	DI2	Digital Input 2 (Optically-Isolated)	Input	
4	DI3	Digital Input 3 (Optically-Isolated)	Input	
5	DIC	Digital Input Common	Input	
6	AO0	Analog Output 0	Output	
7	AO1	Analog Output 1	Output	
8	+5V	+5V (500 mA maximum)	Output	

Table 2-19: Mating Connector Part Numbers for the Digital / Analog I/O Connectors

Specification		Description
Type		8-Pin Terminal Block
Part Numbers		Aerotech: ECK02397
		Phoenix: 1908101
Conductor Cross Section	Solid or stranded	20...26 AWG (0.14...0.5 mm ²)
	Stranded, with ferrule, without plastic sleeve	20...24 AWG (0.25...0.5 mm ²)
Conductor Insulation Strip Length		8 mm (5/16 in)
(1) Refer to the manufacturer website for additional information.		

2.6.1. Digital Outputs

Optically-isolated solid-state relays drive the digital outputs. You can connect the digital outputs in current sourcing or current sinking mode but you must connect all four outputs in the same configuration. Refer to [Figure 2-7](#) and [Figure 2-8](#).

You must install suppression diodes on digital outputs that drive relays or other inductive devices. To see an example of a current sourcing output that has diode suppression, refer to [Figure 2-7](#). To see an example of a current sinking output that has diode suppression, refer to [Figure 2-8](#).

The digital outputs are not designed for high-voltage isolation applications and they should only be used with ground-referenced circuits.

The digital outputs have overload protection. They will resume normal operation when the overload is removed.

Table 2-20: Digital Output Specifications

Digital Output Specifications	Value
Maximum Voltage	24 V (26 V Maximum)
Maximum Sink/Source Current	50 mA/output
Output Saturation Voltage	0.2 V at maximum current
Output Resistance	4 Ω
Rise / Fall Time	250 μ s (2K pull up to 24V)
Reset State	Output Off (High Impedance State)

Table 2-21: Digital Output Pins on the Digital/Analog I/O A Connector

Pin #	Label	Description	In/Out/Bi
1	DO0	Digital Output 0 (Optically-Isolated)	Output
2	DO1	Digital Output 1 (Optically-Isolated)	Output
3	DO2	Digital Output 2 (Optically-Isolated)	Output
4	DO3	Digital Output 3 (Optically-Isolated)	Output
5	DOC	Digital Output Common	Output

Figure 2-7: Digital Outputs Connected in Current Sourcing Mode

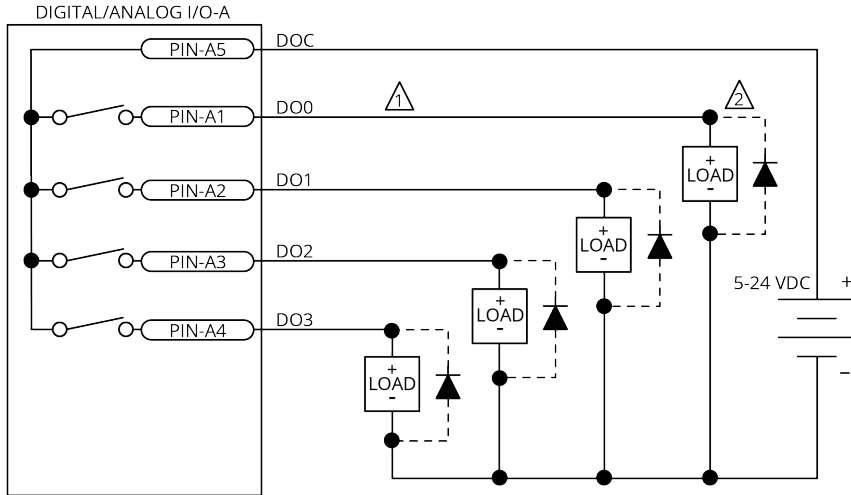

⚠ Each output 50 mA maximum

⚡ Diode required on each output that drives an inductive device (coil), such as a relay.

Figure 2-8: Digital Outputs Connected in Current Sinking Mode

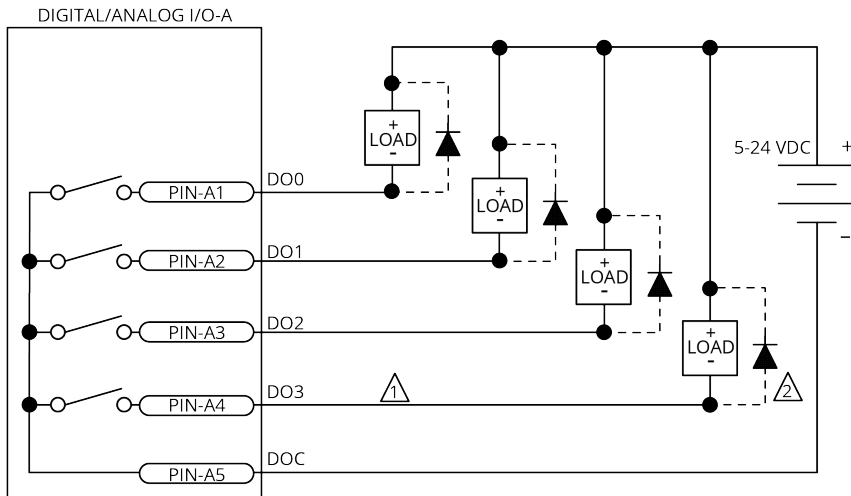

⚠ Each output 50 mA maximum

⚡ Diode required on each output that drives an inductive device (coil), such as a relay.

2.6.2. Digital Inputs

You can connect the digital inputs to current sourcing or current sinking devices but you must connect all four inputs in the same configuration. Refer to [Figure 2-9](#) and [Figure 2-10](#). The digital inputs are not designed for high-voltage isolation applications. They should only be used with ground-referenced circuits.

Table 2-22: Digital Input Specifications

Input Voltage	Approximate Input Current	Turn On Time	Turn Off Time
+5 V to +24 V	6 mA	10 μ s	43 μ s

Table 2-23: Digital Input Pins on the Digital/Analog I/O B Connector

Pin #	Label	Description	In/Out/Bi
1	DI0	Digital Input 0 (Optically-Isolated)	Input
2	DI1	Digital Input 1 (Optically-Isolated)	Input
3	DI2	Digital Input 2 (Optically-Isolated)	Input
4	DI3	Digital Input 3 (Optically-Isolated)	Input
5	DIC	Digital Input Common	Input

Figure 2-9: Digital Inputs Connected to Current Sourcing Devices

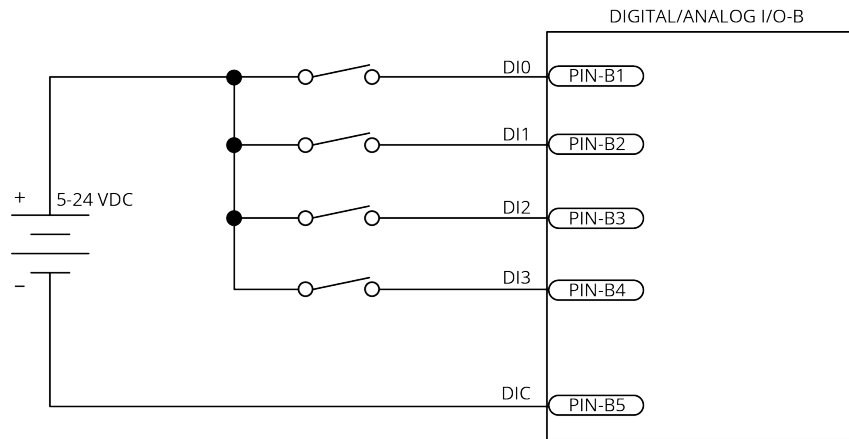
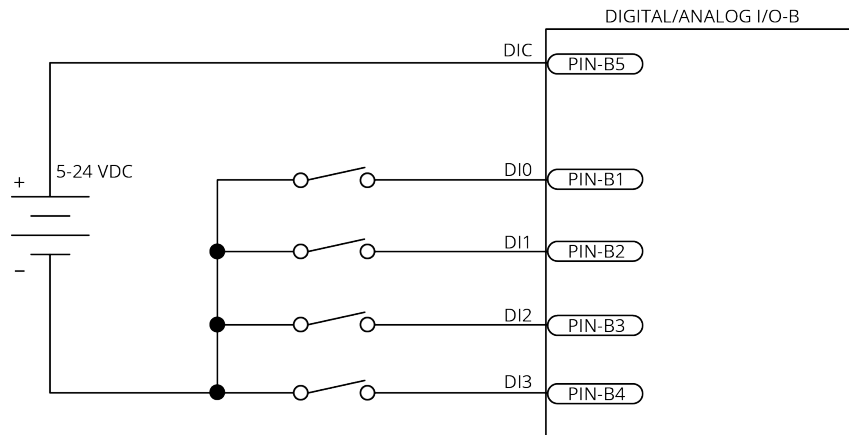

Figure 2-10: Digital Inputs Connected to Current Sinking Devices



2.6.3. Analog Outputs

The analog outputs can be set from within a program or they can be configured to echo the state of select servo loop nodes.

The analog outputs are set to zero when you power on the system or reset the drive.

Table 2-24: Analog Output Specifications

Specification	Value
Output Voltage	-10 V to +10 V
Output Current	5 mA
Resolution (bits)	16 bits

Table 2-25: Analog Output Pins on the Digital / Analog I/O B Connector

Pin #	Label	Description	In/Out/Bi
6	AO0	Analog Output 0	Output
7	AO1	Analog Output 1	Output

Figure 2-11: Analog Outputs Schematic

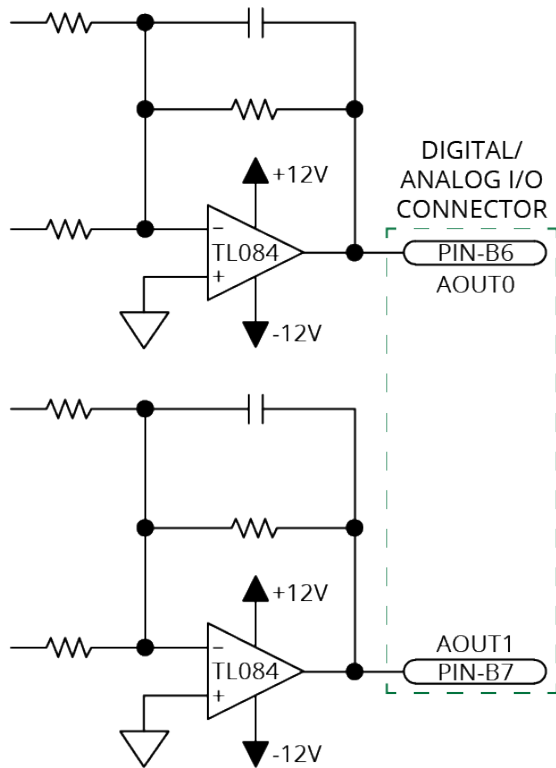

2.6.4. Analog Inputs (Differential)

To interface to a single-ended, non-differential voltage source, connect the signal common of the source to the negative input and connect the analog source signal to the positive input. A floating signal source must be referenced to the analog common. Refer to [Figure 2-12](#).

Table 2-26: Analog Input Specifications

Specification	Value
(AI+) - (AI-)	+10 V to -10 V ⁽¹⁾
Resolution (bits)	16 bits
Input Impedance	1 MΩ
1. Signals outside of this range may damage the input	

Table 2-27: Analog Input Pins on the Digital / Analog I/O B Connector

Pin #	Label	Description	In/Out/Bi
6	AI+	Analog Input +	Input
7	AI-	Analog Input -	Input
8	GND	Ground	N/A

Figure 2-12: Analog Inputs Schematic

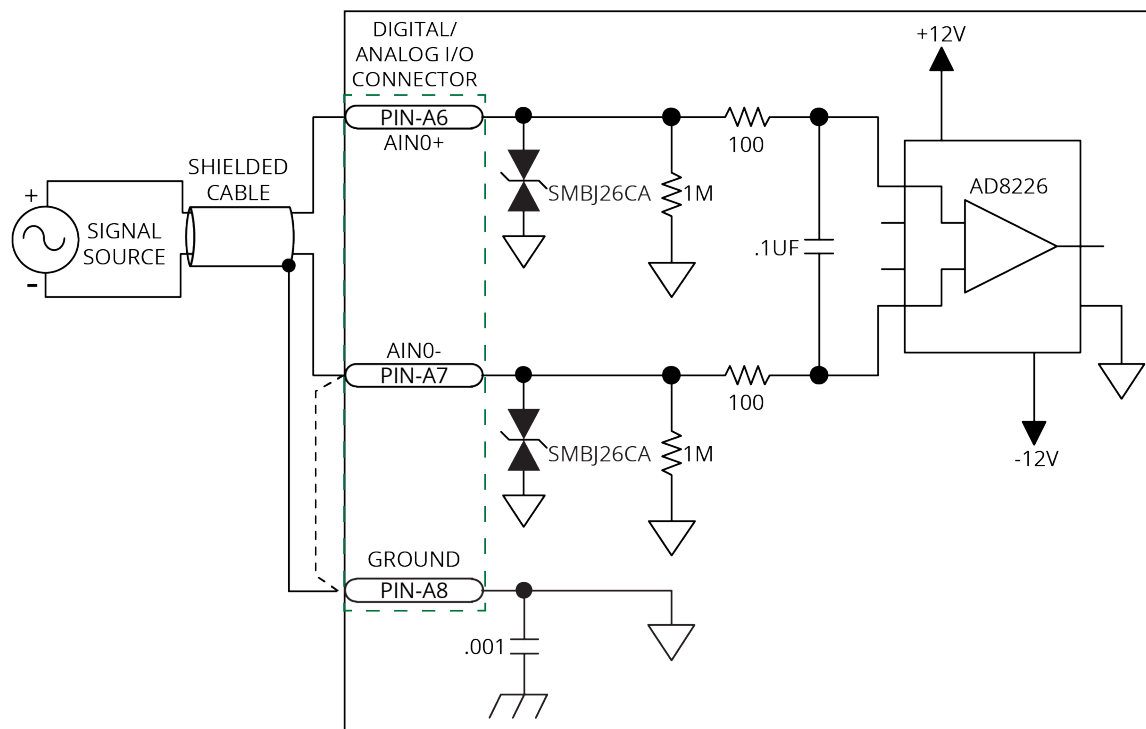

2.7. Encoder Input Connectors

The drive has one auxiliary encoder channel. The encoder interface accepts an RS-422 differential line driver. You cannot use the auxiliary encoder channels to close the position loop.

Table 2-28: Encoder Input Connector Specifications

Specification	Value
Encoder Frequency	10 MHz maximum (25 ns minimum edge separation)
x4 Quadrature Decoding	40 million counts/sec

Table 2-29: Encoder Input Connector A Pinout

Pin	Label	Description	In/Out/Bi	Connector
1	SIN1+	Encoder SIN+ Input	Input	
2	SIN1-	Encoder SIN- Input	Input	
3	COS1+	Encoder COS+ Input	Input	
4	COS1-	Encoder COS- Input	Input	
5	ESTOP+	Emergency Stop Opto-Isolated Input +	Input	
6	ESTOP-	Emergency Stop Opto-Isolated Input -	Input	

Table 2-30: Encoder Input Connector B Pinout

Pin	Label	Description	In/Out/Bi	Connector
1	SIN2+	Reserved	N/A	
2	SIN2-	Reserved	N/A	
3	COS2+	Reserved	N/A	
4	COS2-	Reserved	N/A	
5	+5V	+5V Encoder Power (500 mA max)	Output	
6	GND	Ground	N/A	

Table 2-31: Mating Connector Part Numbers for the Encoder Input Connector

Specification	Description
Type	6-Pin Terminal Block
Part Numbers	Aerotech: ECK02405
	Phoenix: 1704755
Conductor Cross Section	Solid or stranded
	Stranded, with ferrule, without plastic sleeve
Conductor Insulation Strip Length	8 mm (5/16 in)
(1) Refer to the manufacturer website for additional information.	

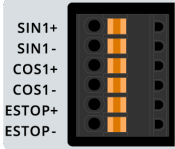
Figure 2-13: Encoder Input Connector Encoder Connections

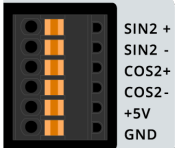
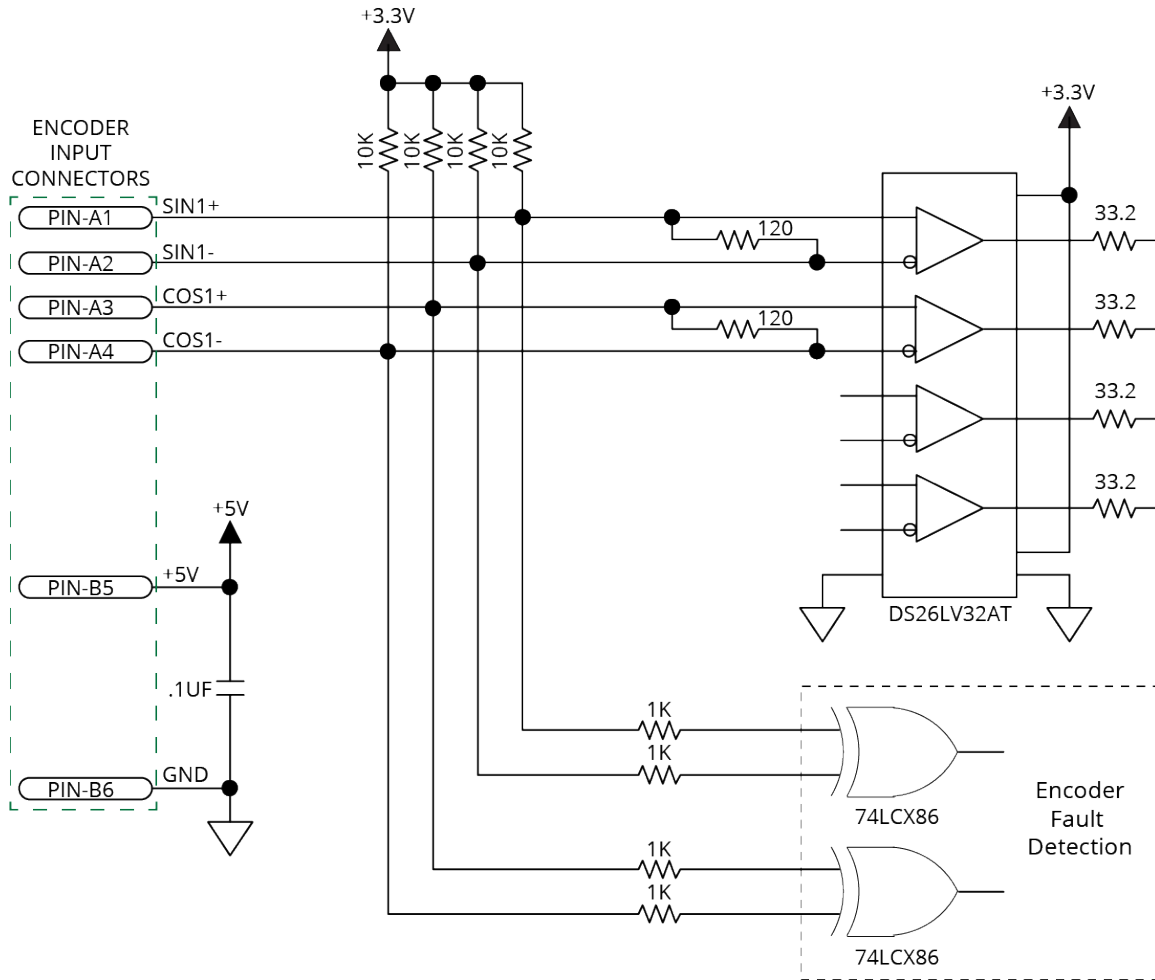

2.7.1. Emergency Stop Sense Input



WARNING: It is your responsibility to assemble the external safety circuits of your system to minimize the risk to the operator.



IMPORTANT: The ESTOP sense input is not a safety-rated system.

Use the ESTOP sense input to monitor the state of an external safety circuit only. The software identifies this state by using the **Emergency Stop Input Level** bit of the Drive Status. To get the software to generate an ESTOP fault when power is removed at the ESTOP input, set the ESTOP bit in the FaultMask parameter.

The ESTOP input is scaled for an input voltage of 12 - 24 volts.

Figure 2-14: ESTOP Sense Input Schematic

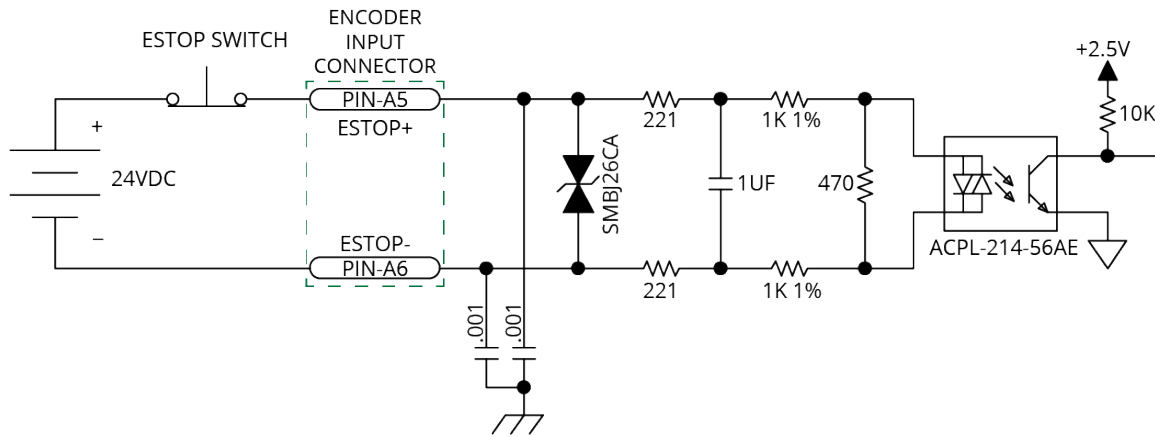

Table 2-32: ESTOP Pins on the Encoder Input Connector

Pin #	Label	Description	In/Out/Bi
5	ESTOP+	Emergency Stop Digital Input +	Input
6	ESTOP-	Emergency Stop Digital Input -	Input



IMPORTANT: If you connect the ESTOP input to a device that makes electrical noise, you must connect an electrical noise suppression device across the switched coil. Refer to [Table 2-33](#) to see the types of devices you can use.

Table 2-33: Electrical Noise Suppression Devices

Device	Aerotech P/N	Third Party P/N
RC (.1uf / 200 ohm) Network	EIC00240	Electrocube RG1782-8
Varistor	EID00160	Littelfuse V250LA40A

2.8. Laser Output Polarity Switch

The Laser Output Polarity switches are reserved for future use.

Figure 2-15: Laser Output Polarity Switch Location

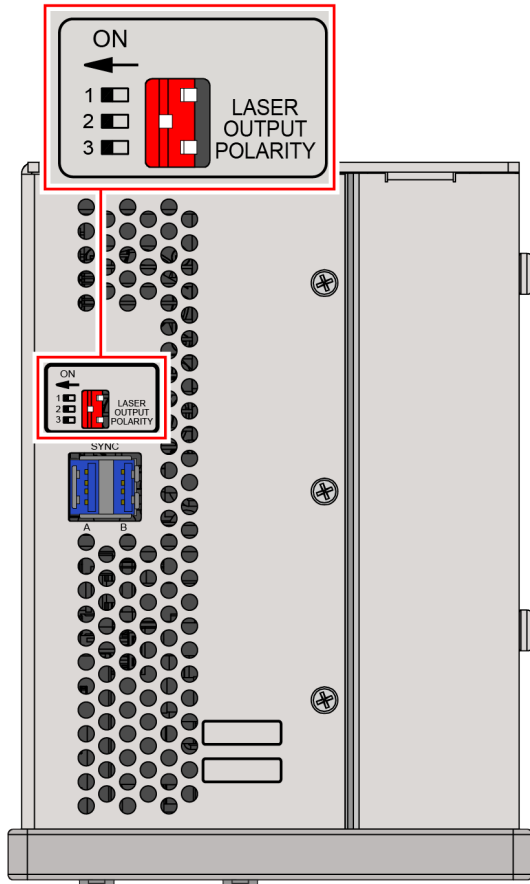

2.9. Sync Port

The Sync port is a bi-directional high speed proprietary interface that lets you transmit encoder signals between drives. The drive contains two Sync ports, labeled A and B. To avoid signal contention, all Sync ports default to the input state during reset and immediately after power is applied to the drive.

This is typically used for multi-axis PSO applications where one or two drives send their encoder signals to a main drive that has the PSO logic and PSO output signal.

Table 2-34: Sync-Related Functions

Function	Description
DriveEncoderOutputConfigureDivider(), DriveEncoderOutputConfigureInput(), DriveEncoderOutputOn(), DriveEncoderOutputOff() [A3200: ENCODER OUT command]	Configure each Sync port as an input or an output
PsoDistanceConfigureInputs() [A3200: PSOTRACK INPUT command]	Let the PSO track the SYNC A or SYNC B port.
PsoWindowConfigureInput() [A3200: PSOWINDOW INPUT command]	

The Sync port uses low-voltage differential signaling (LVDS) and standard USB 3.0 type A (cross over) cables.

Table 2-35: Sync Port Cables

Part Number	Description
CBL-SYNC-3	Length 3 dm; Connectors: USB Type A to USB Type A
CBL-SYNC-5	Length 5 dm; Connectors: USB Type A to USB Type A
CBL-SYNC-7	Length 7 dm; Connectors: USB Type A to USB Type A
CBL-SYNC-10	Length 10 dm; Connectors: USB Type A to USB Type A

2.10. PC Configuration and Operation Information

For more information about hardware requirements, PC configuration, programming, system operation, and utilities, refer to the Help file.

This page intentionally left blank.

Chapter 3: Maintenance



IMPORTANT: For your own safety and for the safety of the equipment:

- Do not remove the cover of the XL4s.
- Do not attempt to access the internal components.

A fuse that needs to be replaced indicates that there is a more serious problem with the system or setup. Contact Global Technical Support for assistance.



DANGER: If you must remove the covers and access any internal components be aware of the risk of electric shock.

1. Disconnect the Mains power connection.
2. Wait at least ten (10) minutes after removing the power supply before doing maintenance or an inspection. Otherwise, there is the danger of electric shock.
3. All tests must be done by an approved service technician. Voltages inside the controller and at the input and output power connections can kill you.

Table 3-1: LED Description

LED	Color	Description
PWR	GREEN	The light will illuminate and remain illuminated while power is applied.
EN/FLT	GREEN	The axis is Enabled.
	RED	The axis is in a Fault Condition.
	GREEN/RED (alternates)	The axis is Enabled in a Fault Condition. or The light is configured to blink for setup.

Table 3-2: Troubleshooting

Symptom	Possible Cause and Solution
No Communication	Make sure the power LED is illuminated (this indicates that power is present).
	Make sure that all communication cables (HyperWire, for example) are fully inserted in their ports.

3.1. Preventative Maintenance

Do an inspection of the XL4s and the external wiring one time each month. It might be necessary to do more frequent inspections based on:

- The operating conditions of the system.
- How you use the system.

Table 3-3: Preventative Maintenance

Check	Action to be Taken
Examine the chassis for hardware and parts that are damaged or loose. It is not necessary to do an internal inspection unless you think internal damage occurred.	Repair all damaged parts.
Do an inspection of the cooling vents.	Remove all material that collected in the vents.
Examine the work area to make sure there are no fluids and no electrically conductive materials.	Do not let fluids and electrically conductive material go into the chassis.
Examine all cables and connections to make sure they are correct.	Make sure that all connections are correctly attached and not loose. Replace cables that are worn. Replace all broken connectors.

Cleaning



DANGER: Before you clean the XL4s, disconnect the electrical power from the drive.

Use a clean, dry, soft cloth to clean the XL4s. If necessary, use a cloth that is moist with water or isopropyl alcohol. If you use a moist cloth, make sure that moisture does not go into the drive. Also make sure that it does not go onto the outer connectors and components. Internal contamination from the cleaning solution can cause corrosion and electrical short circuits.

Do not clean the labels with a cleaning solution because it might remove the label information.

3.2. Board Assembly

Figure 3-1 highlights the important components located on the control board.



DANGER: Before you open the XL4s chassis, you must disconnect the Mains power connection.

Figure 3-1: Control Board Assembly

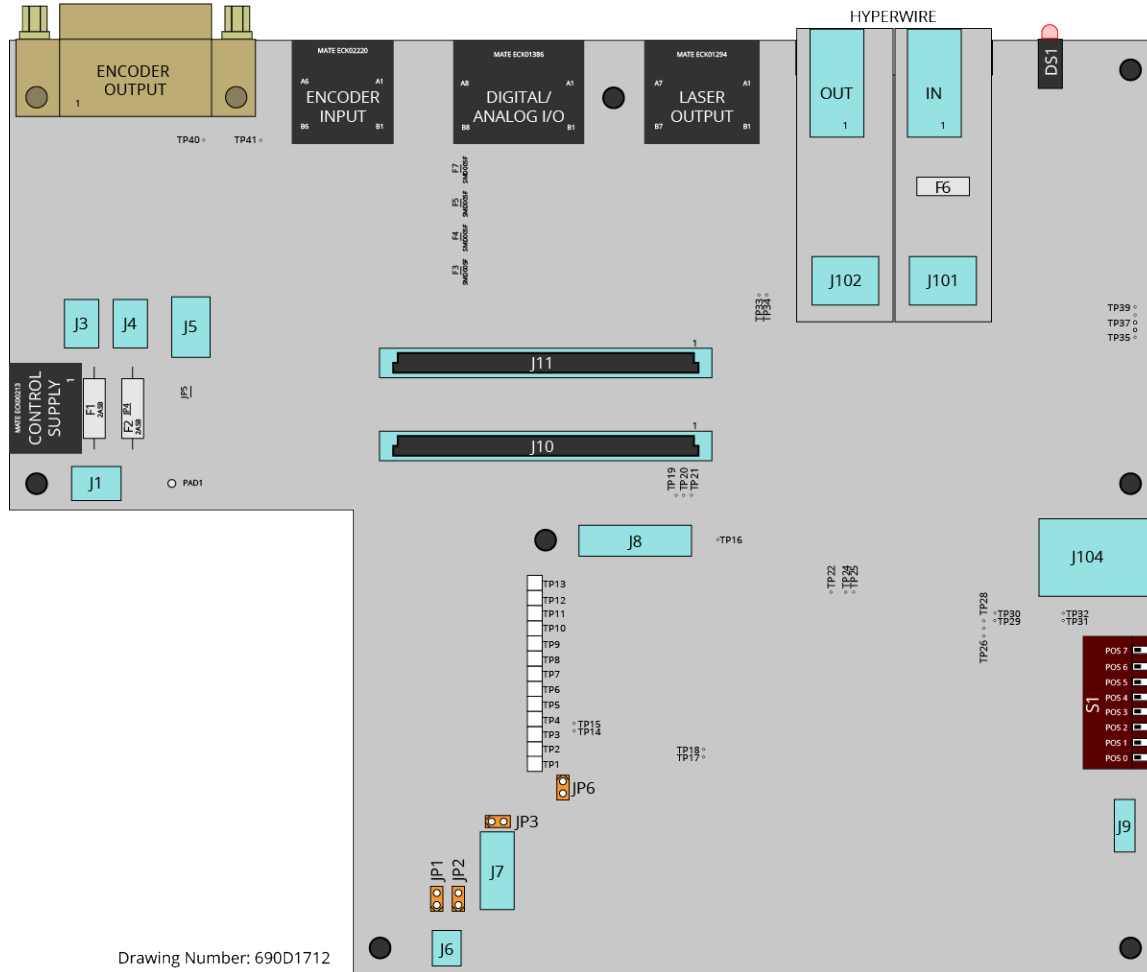

Table 3-4: Control Board Fuse Specifications

Fuse	Description	Size	Aerotech P/N	Third Party P/N
F1	Control Supply Power at Pin-1	2 A S.B.	EIF01048	Littelfuse 0875002.MXEP
F2	Control Supply Power at Pin-1	2 A S.B.	EIF01048	Littelfuse 0875002.MXEP
F6	HyperWire power	--	--	--

NOTE: F6 is a resettable fuse. It is not necessary to replace the fuse. Turn off the power and remove the short circuit.



DANGER: Before you open the XL4s chassis, you must disconnect the Mains power connection.

Figure 3-2: Power Board Assembly

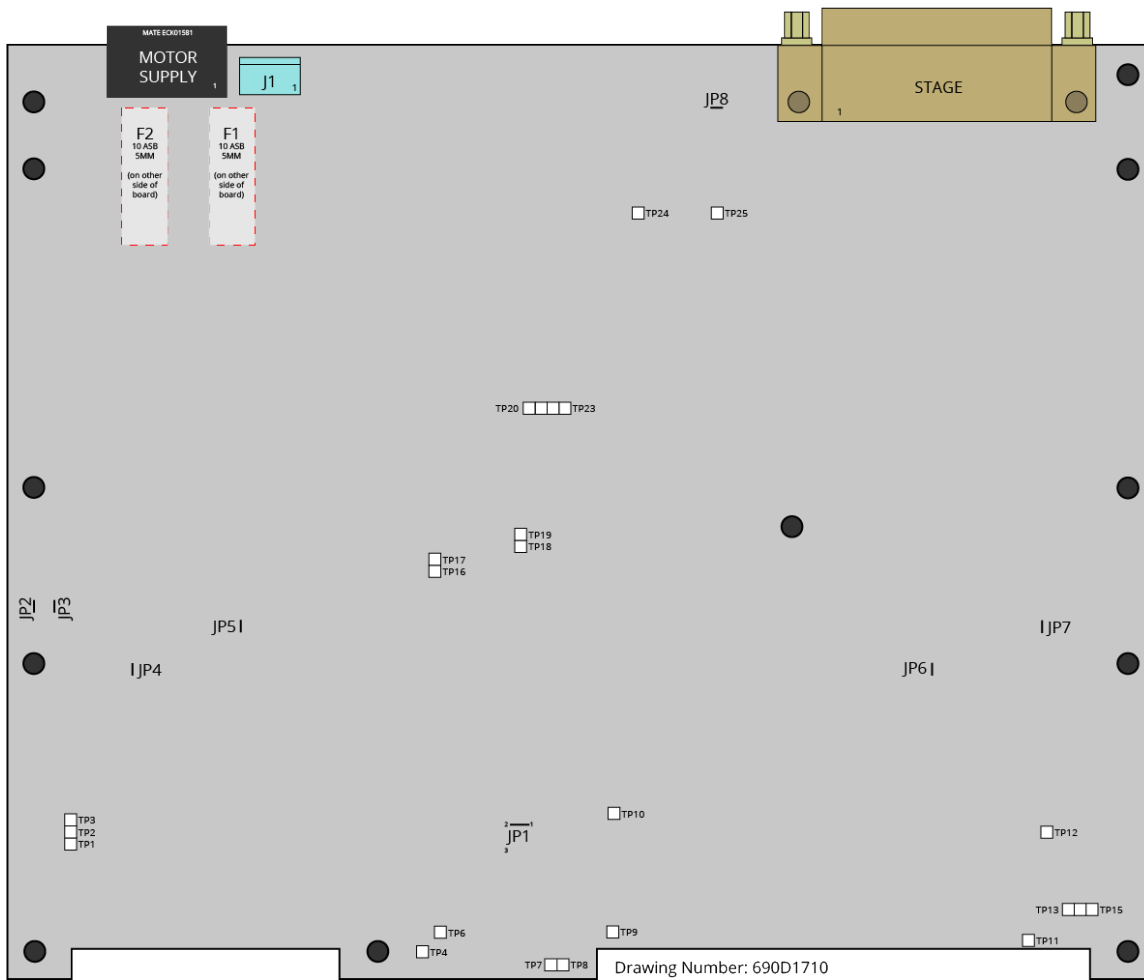

Table 3-5: Power Board Fuse Specifications

Fuse	Description	Size	Aerotech P/N	Third Party P/N
F1	Motor Bus Supply	10 A S.B.	EF01020	Littelfuse 215010.P
F2	Motor Bus Supply	10 A S.B.	EF01020	Littelfuse 215010.P

NOTE: F1 and F2 are on the bottom of the board.

Appendix A: Warranty and Field Service

Aerotech, Inc. warrants its products to be free from harmful defects caused by faulty materials or poor workmanship for a minimum period of one year from date of shipment from Aerotech. Aerotech's liability is limited to replacing, repairing or issuing credit, at its option, for any products that are returned by the original purchaser during the warranty period. Aerotech makes no warranty that its products are fit for the use or purpose to which they may be put by the buyer, whether or not such use or purpose has been disclosed to Aerotech in specifications or drawings previously or subsequently provided, or whether or not Aerotech's products are specifically designed and/or manufactured for buyer's use or purpose. Aerotech's liability on any claim for loss or damage arising out of the sale, resale, or use of any of its products shall in no event exceed the selling price of the unit.

THE EXPRESS WARRANTY SET FORTH HEREIN IS IN LIEU OF AND EXCLUDES ALL OTHER WARRANTIES, EXPRESSED OR IMPLIED, BY OPERATION OF LAW OR OTHERWISE. IN NO EVENT SHALL AEROTECH BE LIABLE FOR CONSEQUENTIAL OR SPECIAL DAMAGES.

Return Products Procedure

Claims for shipment damage (evident or concealed) must be filed with the carrier by the buyer. Aerotech must be notified within thirty (30) days of shipment of incorrect material. No product may be returned, whether in warranty or out of warranty, without first obtaining approval from Aerotech. No credit will be given nor repairs made for products returned without such approval. A "Return Materials Authorization (RMA)" number must accompany any returned product(s). The RMA number may be obtained by calling an Aerotech service center or by submitting the appropriate request available on our website (www.aerotech.com). Products must be returned, prepaid, to an Aerotech service center (no C.O.D. or Collect Freight accepted). The status of any product returned later than thirty (30) days after the issuance of a return authorization number will be subject to review.

Visit [Global Technical Support Portal](#) for the location of your nearest Aerotech Service center.

Returned Product Warranty Determination

After Aerotech's examination, warranty or out-of-warranty status will be determined. If upon Aerotech's examination a warranted defect exists, then the product(s) will be repaired at no charge and shipped, prepaid, back to the buyer. If the buyer desires an expedited method of return, the product(s) will be shipped collect. Warranty repairs do not extend the original warranty period.

Fixed Fee Repairs - Products having fixed-fee pricing will require a valid purchase order or credit card particulars before any service work can begin.

All Other Repairs - After Aerotech's evaluation, the buyer shall be notified of the repair cost. At such time the buyer must issue a valid purchase order to cover the cost of the repair and freight, or authorize the product(s) to be shipped back as is, at the buyer's expense. Failure to obtain a purchase order number or approval within thirty (30) days of notification will result in the product(s) being returned as is, at the buyer's expense.

Repair work is warranted for ninety (90) days from date of shipment. Replacement components are warranted for one year from date of shipment.

Rush Service

At times, the buyer may desire to expedite a repair. Regardless of warranty or out-of-warranty status, the buyer must issue a valid purchase order to cover the added rush service cost. Rush service is subject to Aerotech's approval.

On-site Warranty Repair

If an Aerotech product cannot be made functional by telephone assistance or by sending and having the customer install replacement parts, and cannot be returned to the Aerotech service center for repair, and if Aerotech determines the problem could be warranty-related, then the following policy applies:

Aerotech will provide an on-site Field Service Representative in a reasonable amount of time, provided that the customer issues a valid purchase order to Aerotech covering all transportation and subsistence costs. For warranty field repairs, the customer will not be charged for the cost of labor and material. If service is rendered at times other than normal work periods, then special rates apply.

If during the on-site repair it is determined the problem is not warranty related, then the terms and conditions stated in the following "On-Site Non-Warranty Repair" section apply.

On-site Non-Warranty Repair

If any Aerotech product cannot be made functional by telephone assistance or purchased replacement parts, and cannot be returned to the Aerotech service center for repair, then the following field service policy applies:

Aerotech will provide an on-site Field Service Representative in a reasonable amount of time, provided that the customer issues a valid purchase order to Aerotech covering all transportation and subsistence costs and the prevailing labor cost, including travel time, necessary to complete the repair.

Service Locations

<https://www.aerotech.com/contact-sales.aspx?mapState=showMap>

USA, CANADA, MEXICO

Aerotech, Inc.
Global Headquarters

CHINA

Aerotech China
Full-Service Subsidiary

GERMANY

Aerotech Germany
Full-Service Subsidiary

TAIWAN

Aerotech Taiwan
Full-Service Subsidiary

UNITED KINGDOM

Aerotech United Kingdom
Full-Service Subsidiary

Appendix B: Revision History

Revision	Description
2.09	<ul style="list-style-type: none"> • Feature Summary updated (Section 1.1.) • Analog I/O Schematic updated (Section 2.6.4.)
2.08	New: <ul style="list-style-type: none"> • Korean Certification Updated: <ul style="list-style-type: none"> • Section 2.5.1. Analog Encoder Inputs • Section 2.7.1. Emergency Stop Sense Input
2.07	General updates
2.06	New Section: UKCA Declaration of Conformity
2.05	Revision changes have been archived. If you need a copy of this revision, contact AerotechGlobal Technical Support.
2.04	
2.03	
2.02	
2.01	
2.00	
1.04	
1.03	
1.02	
1.01	
1.00	

This page intentionally left blank.

O		R	
Operation	21	Revision History	53
Order Options	16		
Output Voltage	18		
Overview	15		
P		S	
packing list	12	Safety Procedures and Warnings	10
PC Configuration and Operation Information	45	serial number	12
Peak Output Current	18	Specifications	
Pinout		Analog Encoder Input	34
Analog Input Pins (Digital / Analog I/O B Connector)	40	Analog Input (Digital / Analog I/O B Connector)	40
Analog Output Pins (Digital / Analog I/O B Connector)	39	Analog Output (Digital and Analog I/O Connector)	39
Digital and Analog I/O Connector A	35	Control Board Fuses	49
Digital and Analog I/O Connector B	35	Control Supply Connector Wiring	24
Digital Input Pins (Digital/Analog I/O B Connector)	38	Digital Inputs	38
Digital Output Pins (Digital/Analog I/O A Connector)	36	Digital Outputs	36
Encoder Input Connector A	41	Encoder Input Connector	41
Encoder Input Connector B	41	Motor Supply Wiring	25
Encoder Output Connector	31	Power Board Fuses	50
ESTOP Pins on the Encoder Input Connector	43	PSO	30
PSO (Connector A)	29	Unit Weight	19
PSO (Connector B)	29	Stage Motor and Feedback Connector	33
Stage Motor and Feedback Connector	33	Mating Connector Part Numbers	33
Pollution	21	Stage Motor and Feedback Connector Pinout	33
Position Synchronized Output Connector	29	Storage	12
Power Board Assembly	50	Sync-Related Commands	45
Power Board Fuse Specifications	50	Sync Port	
Power Supply Options	26	PSO Tracking	45
Preventative Maintenance	48	Sync Port Cables	45
PSO		Sync Ports	45
Sync Port (multi axis tracking)	45	System part number	12
PSO Connector	29		
PSO Connector A Pinout	29	T	
PSO Connector B Pinout	29	Table of Contents	3
PSO Connectors		Temperature	21
Mating Connector Part Numbers	29	Third-Party Power Supply Connection	26
PSO External Sync Input Schematic	32	Three-axis Part-Speed PSO Firing	16
PSO External Sync Specifications	32	TM3 Transformer Control and Power Wiring	27
PSO Output Sources	30		
PSO Specifications	30	U	
PSO Tracking		Unit Weight	19
Sync Port	45	Use	21
		User Power Supply Output	18

W

Warranty and Field Service

51